

Title	Cognitive radio adaptive rendezvous protocols to establish network services for a disaster response
Authors	Ghafoor, Saim
Publication date	2018
Original Citation	Ghafoor, S. 2018. Cognitive radio adaptive rendezvous protocols to establish network services for a disaster response. PhD Thesis, University College Cork.
Type of publication	Doctoral thesis
Rights	© 2018, Saim Ghafoor. - http://creativecommons.org/licenses/by-nc-nd/3.0/
Download date	2024-06-09 13:35:48
Item downloaded from	https://hdl.handle.net/10468/7131

Cognitive radio adaptive rendezvous protocols to establish network services for a disaster response

Saim Ghafoor

**Thesis submitted for the degree of
Doctor of Philosophy**



NATIONAL UNIVERSITY OF IRELAND, CORK

DEPARTMENT OF COMPUTER SCIENCE

May 2018

Head of Department: Prof. Cormac J. Sreenan

Supervisors: Prof. Kenneth N. Brown
Prof. Cormac J. Sreenan

Contents

List of Figures	vi
List of Tables	xi
Acknowledgements	xv
Abbreviations	xvi
Abstract	xxi
1 Introduction	1
1.1 Thesis Statement	4
1.2 Key Contributions	5
1.3 Thesis Organization	6
1.4 List of Publications	7
2 Cognitive Radio Based Disaster Response Network: Survey, Potential and Challenges	8
2.1 Introduction	8
2.2 Disaster Response Networks	9
2.2.1 Disaster Response Network Planning	9
2.2.2 Disaster Response Network Requirements	10
2.3 Existing Solutions	11
2.3.1 ETC	11
2.3.2 AT&T	14
2.3.3 Telecom Sans Frontier (TSF)	15
2.3.4 Vodafone Instant Network Program	15
2.3.5 Ericsson Response Team	15
2.3.6 Cisco's Tactical Operations (TacOps)	16
2.3.7 NetHope	16
2.4 Discussion on the existing solutions	16
2.5 Cognitive Radio for Disaster Response Networks	17
2.5.1 Sense and Observe	18
2.5.2 Plan and Decide	18
2.5.3 Act and Coordinate	18
2.6 Cognitive Radio Technology Today	19
2.6.1 Regulations	19
2.6.2 Standardization	19
2.6.3 Enabling Technologies	20
2.6.4 Research Projects	20
2.7 Cognitive Radio Potential and Challenges for Disaster Response Network	22
2.7.1 QoS	22
2.7.2 Robustness and Reliability	23
2.7.3 Coverage and Mobility	24
2.7.4 Rapid Deployment	25
2.7.5 Interoperability	25
2.7.6 Spectrum Agility	26
2.7.7 Self-organization	26

2.7.8	Cost Effectiveness	28
2.8	Discussion on DRN requirements and challenges	28
2.9	Chapter conclusion	29
3	Literature Review	30
3.1	Rendezvous	30
3.2	Rendezvous in cognitive radio networks	31
3.3	Classification of rendezvous protocols in CRNs	32
3.4	Centralized rendezvous protocols	32
3.5	Decentralized rendezvous Protocols	33
3.5.1	Using CCC	34
3.5.2	Channel hopping protocols	34
3.5.2.1	Number theory based Protocols	36
3.5.2.2	Jump-stay based CH protocols	40
3.5.2.3	Quorum based CH protocols	41
3.5.2.4	Galois-field based CH prorocols	43
3.5.2.5	Matrix based CH protocols	43
3.5.2.6	Combinatorial based CH protocols	44
3.5.2.7	Random CH protocols	44
3.6	Discussion on issues of existing CRN rendezvous strategies	45
3.7	Requirements and challenges of a fully blind rendezvous protocols for CR based DRN	48
3.8	Cognitive Radio Operating Policies	50
3.8.1	Policy-based Radio	51
3.9	Primary Radio Activity Model	53
3.10	Cognitive Radio Simulation	55
3.11	Summary of the chapter	57
4	Experimental evaluation of a software defined radio-based prototype for a disaster response cellular network	58
4.1	Introduction	58
4.1.1	Main contributions	60
4.2	Disaster and SDR based Solutions	60
4.2.1	Cellular Backhaul connectivity	61
4.2.2	Differences with existing solutions	63
4.3	Prototype multi-BTS GSM-802.11 network	63
4.3.1	Prototype building blocks	64
4.3.1.1	Universal Software Radio Peripheral	64
4.3.1.2	OpenBTS	64
4.3.1.3	General architecture and external connectivity	66
4.4	Experimental Design	66
4.4.1	Scenarios	67
4.4.1.1	InterBTS Scenario	67
4.4.1.2	IntraBTS Scenario	69
4.4.2	Backhaul Link	69
4.4.3	Background Traffic and Environment	69
4.4.4	Measurement points	69

4.4.5	Equivalent Calls	70
4.4.6	Performance Metrics	70
4.4.6.1	Jitter	71
4.4.6.2	Packet Loss	72
4.4.6.3	Throughput	72
4.4.6.4	Mean Opinion Score (MOS)	72
4.5	Performance Evaluation	72
4.6	Discussion	77
4.7	Chapter conclusion	78
5	An Extended Modular Clock blind rendezvous Protocol	79
5.1	Introduction	79
5.1.1	Main contributions	80
5.2	System Model and Assumptions	80
5.3	Extended Modular Clock Algorithm (EMCA)	81
5.3.1	Overview	81
5.3.2	EMCA Operation	83
5.3.3	Listen Before Talk (LBT) Approach	84
5.3.4	Message Passing based Handshake Mechanism	85
5.3.5	Difference with existing approaches	86
5.3.5.1	Short rendezvous cycle	87
5.3.5.2	Biased channel selection	88
5.3.5.3	PR activity consideration and rendezvous guarantee	89
5.3.5.4	Channels and multiple nodes	90
5.4	Simulation Environment	91
5.4.1	Simulator Setup	91
5.4.2	Simulation Setup	91
5.4.3	Primary User Traffic Patterns	91
5.4.4	Timeslots structure and multiple beacon transmissions	96
5.5	Performance Evaluation	98
5.5.1	Performance Metrics	98
5.5.2	Symmetric channels case	99
5.5.3	Asymmetric channels case	102
5.5.3.1	Average time to rendezvous	102
5.5.3.2	Average harmful interference	105
5.6	Chapter conclusion	109
6	Cognitive Radio Policy based Adaptive Blind Rendezvous Protocols	111
6.1	Introduction	111
6.1.1	Main contributions	112
6.2	Cognitive radio operating policies	113
6.2.1	Normal Policy	115
6.2.2	Reactive Policy	117
6.2.2.1	Reactive Policy without Timeslot Truncation (RwoT)	117
6.2.2.2	Reactive Policy with Timeslot Truncation (RwT)	118
6.2.3	Proactive Policy	118
6.2.4	Extensions of Reactive and Proactive policies	119

6.3	Performance evaluation	120
6.3.1	Average time to rendezvous (ATTR)	122
6.3.1.1	Key observations	122
6.3.1.2	Discussion	127
6.3.2	Average harmful interference	131
6.3.2.1	Key observations	131
6.3.2.2	Discussion	133
6.3.3	Imperfect Sensing	135
6.3.4	Extension of Reactive and Proactive policies	135
6.4	Chapter conclusion	138
7	A fully blind multihop rendezvous protocol	139
7.1	Introduction	139
7.1.1	Main contributions	141
7.2	System Preliminaries and Assumptions	141
7.3	A multihop fully blind rendezvous framework	142
7.3.1	Rendezvous Phase	144
7.3.2	Transition Phase	144
7.3.3	Termination Phase	146
7.4	Scheduling and synchronisation among nodes	150
7.5	Simulation Environment	150
7.5.1	CR operating policies	151
7.5.2	Existing multihop rendezvous strategies	151
7.5.3	Network Environment	151
7.5.4	Performance Metrics	152
7.6	Performance Evaluation	152
7.6.1	Average Time to Rendezvous	152
7.6.1.1	Key observations	153
7.6.1.2	Discussion	160
7.6.2	Average Harmful Interference	160
7.6.2.1	Key observations	160
7.6.2.2	Discussion	163
7.6.3	Neighbour Discovery Accuracy	163
7.6.3.1	Discussion	165
7.6.4	Imperfect sensing	167
7.6.5	Extension of Reactive and Proactive policies	168
7.6.6	Synchronisation and reachability	169
7.7	Discussion	171
7.8	Conclusion	172
8	Conclusions and Future Work	173
8.1	Contributions	174
8.2	Thesis summary and recommendations	176
8.3	Future Work	177
A	Figures	179
A.1	Chapter 6	179

A.2 Chapter 7	191
B Tables	210
B.1 Chapter 6	210
B.2 Chapter 7	225

List of Figures

1.1	Percentage of cell outage due to Hurricane Harvey in August 2017 [2].	2
1.2	Examples of disaster response to restore telecommunication services.	3
2.1	Key cognitive radio mechanisms for disaster response network	17
2.2	Response scenario for an area after communication is destroyed.	23
3.1	Classification of rendezvous protocols in cognitive radio networks.	33
3.2	ACS and selected channels using Modular Clock Algorithm.	37
3.3	Alternating Markov renewal process for PR activity.	54
3.4	Main blocks of Cognitive Radio Network Simulator.	56
4.1	An example for partially destroyed network extension.	61
4.2	Universal Software Radio Peripheral.	64
4.3	System diagram of single/multiple OpenBTS systems.	65
4.4	A general architecture of multiBTS prototype.	66
4.5	Prototype of a disaster response network.	67
4.6	Call flow and measurement points in InterBTS Scenario	68
4.7	Call flow and measurement points in IntraBTS Scenario	68
4.8	Equivalence of real and emulated calls for InterBTS setup in quiet environment.	71
4.9	Equivalence of real and emulated calls for IntraBTS setup in quiet environment.	71
4.10	InterBTS experiments conducted in quiet environment.	73
4.11	IntraBTS experiments conducted in quiet environment.	74
4.12	InterBTS experiments conducted in noisy environment.	75
4.13	IntraBTS experiments conducted in noisy environment.	76
4.14	Mean opinion score.	77
5.1	Example of modular clock algorithm.	82
5.2	Example of extended modular clock algorithm.	84
5.3	neighbour information Passing Mechanism and 3-way handshake.	86
5.4	Four way handshake mechanism.	86
5.5	Rendezvous occurrence distribution among $2P$ timeslots of MCA rendezvous cycle length.	88
5.6	Rendezvous occurrence distribution among $2P$ timeslots of MCA rendezvous cycle length with random channel remap.	89
5.7	Different PR activity patterns.	94
5.8	Timeslot structure and beacon transmission schedule.	96
5.9	Overlapping of timeslots in multiple beacon transmissions.	97
5.10	Beacons transmission per timeslot comparison under under Zero PR activity and 7 channels.	97
5.11	Beacons transmission per timeslot comparison under under High PR activity and 7 channels.	97
5.12	Average TTR for 2 nodes under zero PR activity	100
5.13	Average TTR for 2 nodes under high PR activity	100

5.14	Average Harmful Interference for 2 nodes (High PR activity)	101
5.15	Average time to rendezvous under Zero PR activity.	103
5.16	Average time to rendezvous under Low PR activity.	103
5.17	Average time to rendezvous under Long PR activity.	103
5.18	Average time to rendezvous under High PR activity.	104
5.19	Average time to rendezvous under Intermittent PR activity.	104
5.20	Average time to rendezvous under Mix PR activity.	104
5.21	Average Harmful Interference under Low PR activity.	108
5.22	Average Harmful Interference under Long PR activity.	108
5.23	Average Harmful Interference under High PR activity.	108
5.24	Average Harmful Interference under Intermittent PR activity.	109
5.25	Average Harmful Interference under Mix PR activity.	109
6.1	Functional blocks for spectrum decision and policy.	114
6.2	Classification of CR operating policies.	114
6.3	Normal, Reactive and Proactive operating policies flowchart.	116
6.4	Binary classification of channel's weight calculation parameters.	119
6.5	Extensions of Reactive and Proactive operating policies.	121
6.6	Average TTR with Zero PR activity for 7 channels and 3 BL timeslots.	123
6.7	Average TTR with High PR activity for 7 channels and 3 BL timeslots.	124
6.8	Average TTR with Mix PR activity for 7 channels and 3 BL timeslots.	124
6.9	Average TTR with High PR activity for 14 channels and 3 BL timeslots.	125
6.10	Average TTR with High PR activity for 7 channels and 10 BL timeslots.	126
6.11	Average TTR with High PR activity for 14 channels and 10 BL timeslots.	126
6.12	Average time to rendezvous (2 nodes, 7 channels, 600 TS CNP time, and High PR activity).	127
6.13	Average HI with High PR activity for 7 channels and 3 BL timeslots.	132
6.14	Average HI with Intermittent PR activity for 7 channels and 3 BL TSs.	132
6.15	Average HI with Mix PR activity for 7 channels and 3 BL timeslots.	132
6.16	Average HI with High PR activity for 14 channels and 3 BL timeslots.	134
6.17	Average HI with High PR activity for 7 channels and 10 BL timeslots.	134
6.18	Average harmful interference (2 nodes, 7 channels, 600 TS CNP time, and High PR activity).	134
6.19	Average TTR and HI under imperfect sensing of 0.1 probability (2 nodes, 7 channels, 3 TS CNP time, and High PR activity)	136
6.20	Average TTR and HI for policies extension (2 nodes, 7 channels, 3 TS CNP time, and High PR activity)	137
6.21	Average TTR and HI for policies extension (10 nodes, 7 channels, 3 TS CNP time, and High PR activity)	137
7.1	Multihop network scenario.	142
7.2	Multihop rendezvous protocol state diagram.	145
7.3	Average TTR for multihop (7 ch, 3 BL TSs and Zero PR activity).	154
7.4	Average TTR for multihop (7 ch, 3 BL TSs and High PR activity).	155
7.5	Average TTR for multihop (7 ch, 3 BL TSs and Mix PR activity).	155
7.6	Average TTR for multihop (14 ch, 3 BL TSs and High PR activity).	155

7.7	Average TTR for multihop (7 ch, 10 BL TSs and High PR activity).	157
7.8	Average TTR (3 nodes, 7 ch, 600 BL TSs and High PR activity).	157
7.9	Average HI for multihop (7 ch, 3 BL TSs and High PR activity).	161
7.10	Average HI for multihop (7 ch, 3 BL TSs and Mix PR activity).	161
7.11	Average HI for multihop (14 ch, 3 BL TSs and High PR activity).	161
7.12	Average HI for multihop (7 ch, 10 BL TSs and High PR activity).	163
7.13	Average HI for multihop (3 nodes, 7 ch, 600 BL TSs and High PR).	163
7.14	Average NDA for multihop (7 ch, 3 BL TSs and Zero PR activity).	165
7.15	Average NDA for multihop (7 ch, 3 BL TSs and High PR activity).	165
7.16	Average NDA for multihop (7 ch, 3 BL TSs and Mix PR activity).	166
7.17	Average NDA for multihop (14 ch, 3 BL TSs and High PR activity).	166
7.18	Average NDA for multihop (7 ch, 10 BL TSs and High PR activity).	166
7.19	Average NDA for multihop (3 nodes, 7 ch, 600 BL TSs, and High PR).	167
7.20	Imperfect sensing for multihop (3 nodes, 7 ch, 3 BL TSs and High PR).	168
7.21	ATTR for policies extension (7 ch, 3 BL TSs and High PR activity).	169
7.22	Average HI for policies extension (7 ch, 3 BL TSs and High PR activity).	170
7.23	Average NDA for policies extension (7 ch, 3 BL TSs and High PR activity).	170
A.1	Average TTR for single-hop (7 ch, 3 BL TSs and Low PR activity).	179
A.2	Average TTR for single-hop (7 ch, 3 BL TSs and Long PR activity).	180
A.3	Avg TTR for single-hop (7 ch, 3 BL TSs and Intermittent PR activity).	180
A.4	Average TTR for single-hop (14 ch, 3 BL TSs and Zero PR activity).	180
A.5	Average TTR for single-hop (14 ch, 3 BL TSs and Low PR activity).	181
A.6	Average TTR for single-hop (14 ch, 3 BL TSs and Long PR activity).	181
A.7	Avg TTR for single-hop (14 ch, 3 BL TSs and Intermittent PR activity).	181
A.8	Average TTR for single-hop (14 ch, 3 BL TSs and Mix PR activity).	182
A.9	Average TTR for single-hop (7 ch, 10 BL TSs and Zero PR activity).	182
A.10	Average TTR for single-hop (7 ch, 10 BL TSs and Low PR activity).	182
A.11	Average TTR for single-hop (7 ch, 10 BL TSs and Long PR activity).	183
A.12	Avg TTR for single-hop (7 ch, 10 BL TSs and Intermittent PR activity).	183
A.13	Average TTR for single-hop (7 ch, 10 BL TSs and Mix PR activity).	183
A.14	Average TTR for single-hop (14 ch, 10 BL TSs and Zero PR activity).	184
A.15	Average TTR for single-hop (14 ch, 10 BL TSs and Low PR activity).	184
A.16	Average TTR for single-hop (14 ch, 10 BL TSs and Long PR activity).	184
A.17	Avg TTR for single-hop (14 ch, 10 BL TSs and Intermittent PR activity).	185
A.18	Average TTR for single-hop (14 ch, 10 BL TSs and Mix PR activity).	185
A.19	Average HI for single-hop (7 ch, 3 BL TSs and Low PR activity).	185
A.20	Average HI for single-hop (7 ch, 3 BL TSs and Long PR activity).	186
A.21	Average HI for single-hop (14 ch, 3 BL TSs and Low PR activity).	186
A.22	Average HI for single-hop (14 ch, 3 BL TSs and Long PR activity).	186
A.23	Avg HI for single-hop (14 ch, 3 BL TSs and Intermittent PR activity).	187
A.24	Average HI for single-hop (14 ch, 3 BL TSs and Mix PR activity).	187
A.25	Average HI for single-hop (7 ch, 10 BL TSs and Low PR activity).	187
A.26	Average HI for single-hop (7 ch, 10 BL TSs and Long PR activity).	188
A.27	Avg HI for single-hop (7 ch, 10 BL TSs and Intermittent PR activity).	188

A.28 Average HI for single-hop (7 ch, 10 BL TSs and Mix PR activity). . .	188
A.29 Average HI for single-hop (14 ch, 10 BL TSs and Low PR activity). . .	189
A.30 Average HI for single-hop (14 ch, 10 BL TSs and Long PR activity). . .	189
A.31 Average HI for single-hop (14 ch, 10 BL TSs and High PR activity). . .	189
A.32 Avg HI for single-hop (14 ch, 10 BL TSs and Intermittent PR activity). . .	190
A.33 Average HI for single-hop (14 ch, 10 BL TSs and Mix PR activity). . .	190
A.34 Average TTR for multihop (7 ch, 3 BL TSs and Low PR activity). . .	191
A.35 Average TTR for multihop (7 ch, 3 BL TSs and Long PR activity). . .	191
A.36 Average TTR for multihop (7 ch, 3 BL TSs and Intermittent PR activity). . .	192
A.37 Average TTR for multihop (14 ch, 3 BL TSs and Zero PR activity). . .	192
A.38 Average TTR for multihop (14 ch, 3 BL TSs and Low PR activity). . .	192
A.39 Average TTR for multihop (14 ch, 3 BL TSs and Long PR activity). . .	193
A.40 Avg TTR for multihop (14 ch, 3 BL TSs and Intermittent PR activity). . .	193
A.41 Average TTR for multihop (14 ch, 3 BL TSs and Mix PR activity). . .	193
A.42 Average TTR for multihop (7 ch, 10 BL TSs and Zero PR activity). . .	194
A.43 Average TTR for multihop (7 ch, 10 BL TSs and Low PR activity). . .	194
A.44 Average TTR for multihop (7 ch, 10 BL TSs and Long PR activity). . .	194
A.45 Avg TTR for multihop (7 ch, 10 BL TSs and Intermittent PR activity). . .	195
A.46 Average TTR for multihop (7 ch, 10 BL TSs and Mix PR activity). . .	195
A.47 Average TTR for multihop (14 ch, 10 BL TSs and Zero PR activity). . .	195
A.48 Average TTR for multihop (14 ch, 10 BL TSs and Low PR activity). . .	196
A.49 Average TTR for multihop (14 ch, 10 BL TSs and Long PR activity). . .	196
A.50 Average TTR for multihop (14 ch, 10 BL TSs and High PR activity). . .	196
A.51 Avg TTR for multihop (14 ch, 10 BL TSs and Intermittent PR activity). . .	197
A.52 Average TTR for multihop (14 ch, 10 BL TSs and Mix PR activity). . .	197
A.53 Average HI for multihop (7 ch, 3 BL TSs and Low PR activity). . . .	197
A.54 Average HI for multihop (7 ch, 3 BL TSs and Long PR activity). . . .	198
A.55 Average HI for multihop (7 ch, 3 BL TSs and Intermittent PR activity). . .	198
A.56 Average HI for multihop (14 ch, 3 BL TSs and Low PR activity). . . .	198
A.57 Average HI for multihop (14 ch, 3 BL TSs and Long PR activity). . . .	199
A.58 Average HI for multihop (14 ch, 3 BL TSs and Intermittent PR activity). . .	199
A.59 Average HI for multihop (14 ch, 3 BL TSs and Mix PR activity). . . .	199
A.60 Average HI for multihop (7 ch, 10 BL TSs and Low PR activity). . . .	200
A.61 Average HI for multihop (7 ch, 10 BL TSs and Long PR activity). . . .	200
A.62 Average HI for multihop (7 ch, 10 BL TSs and Intermittent PR activity). . .	200
A.63 Average HI for multihop (7 ch, 10 BL TSs and Mix PR activity). . . .	201
A.64 Average HI for multihop (14 ch, 10 BL TSs and Low PR activity). . . .	201
A.65 Average HI for multihop (14 ch, 10 BL TSs and Long PR activity). . . .	201
A.66 Average HI for multihop (14 ch, 10 BL TSs and High PR activity). . . .	202
A.67 Average HI for multihop (14 ch, 10 BL TSs and Intermittent PR activity).	202
A.68 Average HI for multihop (14 ch, 10 BL TSs and Mix PR activity). . . .	202
A.69 Average NDA for multihop (7 ch, 3 BL TSs and Low PR activity). . . .	203
A.70 Average NDA for multihop (7 ch, 3 BL TSs and Long PR activity). . . .	203
A.71 Average NDA for multihop (7 ch, 3 BL TSs and Intermittent PR activity).	203

A.72 Average NDA for multihop (14 ch, 3 BL TSs and Zero PR activity).	. .	204
A.73 Average NDA for multihop (14 ch, 3 BL TSs and Low PR activity).	. .	204
A.74 Average NDA for multihop (14 ch, 3 BL TSs and Long PR activity).	. .	205
A.75 Avg NDA for multihop (14 ch, 3 BL TSs and Intermittent PR activity).		205
A.76 Average NDA for multihop (14 ch, 3 BL TSs and Mix PR activity).	. .	205
A.77 Average NDA for multihop (7 ch, 10 BL TSs and Zero PR activity).	. .	206
A.78 Average NDA for multihop (7 ch, 10 BL TSs and Low PR activity).	. .	206
A.79 Average NDA for multihop (7 ch, 10 BL TSs and Long PR activity).	. .	206
A.80 Avg NDA for multihop (7 ch, 10 BL TSs and Intermittent PR activity).		207
A.81 Average NDA for multihop (7 ch, 10 BL TSs and Mix PR activity).	. .	207
A.82 Average NDA for multihop (14 ch, 10 BL TSs and Zero PR activity).	. .	207
A.83 Average NDA for multihop (14 ch, 10 BL TSs and Low PR activity).	. .	208
A.84 Average NDA for multihop (14 ch, 10 BL TSs and Long PR activity).		208
A.85 Average NDA for multihop (14 ch, 10 BL TSs and High PR activity).		208
A.86 Avg NDA for multihop (14 ch, 10 BL TSs and Intermittent PR activity).		209
A.87 Average NDA for multihop (14 ch, 10 BL TSs and Mix PR activity).	. .	209

List of Tables

2.1	DRN Requirements [5]	12
2.2	DRN Capabilities in Existing Solutions Provided by Different Organizations [5]	13
2.3	Projects Related to Cognitive Radio and Disaster Response [5]	21
2.4	Potential, Issues and Challenges for Cognitive Radio in Disaster Response [5]	27
3.1	Rendezvous protocols in Cognitive Radio Networks	35
3.2	Example of Modular Clock Algorithm	37
3.3	Standard recommendations for TV and radar bands	52
4.1	Existing Backhaul Technologies [100]	61
4.2	System parameters of DRN prototype	67
5.1	Percentage of rendezvous non-occurrence in overall rendezvous cycles (shared channels case).	90
5.2	Rate parameters values for channel states used in the simulations	95
5.3	ATTR and HI for 2 nodes with symmetric channels, synchronous and asynchronous timeslots.	101
5.4	ATTR and HI for asymmetric channels and asynchronous timeslots.	106
5.5	Percentage improvement of EMCA over other rendezvous protocols in terms of TTR (asymmetric channels case).	107
6.1	Simulation Parameters	122
6.2	Average TTR for single-hop (2 nodes and 3 BL timeslots)	129
6.3	Average TTR for single-hop (10 nodes and 3 BL timeslots)	130
6.4	Average number of times PR appears during a timeslot for a node using MMCA protocol (2 nodes, 7 CHs, and 3 BL TSs)	136
7.1	Average TTR for multihop (3 nodes and 3 BL timeslots)	158
7.2	Average TTR for multihop (10 nodes and 3 BL timeslots)	159
7.3	Performance of synchronisation and reachability among the discovered neighbours	171
B.1	Percentage improvement of EMCA over other rendezvous strategies in terms of ATTR (2 nodes, 3 BL TS)	211
B.2	Percentage improvement of EMCA over other rendezvous strategies in terms of ATTR (10 nodes, 3 BL TS)	212
B.3	Percentage improvement of policies over LBT for each rendezvous strategy (2 nodes, 3 BL TSs)	213
B.4	Percentage improvement of policies over LBT for each rendezvous strategy (10 nodes, 3 BL TSs)	214
B.5	Average HI for single-hop (2 nodes and 3 BL timeslots)	215
B.6	Average HI for single-hop (10 nodes and 3 BL timeslots)	216
B.7	Average TTR for single-hop (2 nodes and 10 BL timeslots)	217

B.8	Average TTR for single-hop (10 nodes and 10 BL timeslots)	218
B.9	Percentage improvement of EMCA over other rendezvous strategies in terms of ATTR (2 nodes, 10 BL TS)	219
B.10	Percentage improvement of EMCA over other rendezvous strategies in terms of ATTR (10 nodes, 10 BL TS)	220
B.11	Percentage improvement of policies over LBT for each rendezvous strategy (2 nodes, 10 BL TSs)	221
B.12	Percentage improvement of policies over LBT for each rendezvous strategy (10 nodes, 10 BL TSs)	222
B.13	Average HI for single-hop (2 nodes and 10 BL timeslots)	223
B.14	Average HI for single-hop (10 nodes and 10 BL timeslots)	224
B.15	Percentage improvement of multihop EMCA over other rendezvous strategies in terms of ATTR (2 nodes, 3 BL TSs)	226
B.16	Percentage improvement of multihop EMCA over other rendezvous strategies in terms of ATTR (10 nodes, 3 BL TSs)	227
B.17	Average HI for multihop (2 nodes and 3 BL timeslots)	228
B.18	Average HI for multihop (10 nodes and 3 BL timeslots)	229
B.19	Average TTR for multihop (2 nodes and 10 BL timeslots)	230
B.20	Average TTR for multihop (10 nodes and 10 BL timeslots)	231
B.21	Percentage improvement of multihop EMCA over other rendezvous strategies in terms of ATTR (2 nodes, 10 BL TSs)	232
B.22	Percentage improvement of multihop EMCA over other rendezvous strategies in terms of ATTR (10 nodes, 10 BL TSs)	233
B.23	Average HI for multihop (2 nodes and 10 BL timeslots)	234
B.24	Average HI for multihop (10 nodes and 10 BL timeslots)	235

I, Saim Ghafoor, certify that this thesis is my own work and has not been submitted for another degree at University College Cork or elsewhere.

Saim Ghafoor

To my Baba and Ami.

Acknowledgements

All praise is due to Allah, I thank Him and seek His help, guidance, and forgiveness.

Firstly, I am indebted to my supervisors Professor Kenneth N. Brown and Professor Cormac J. Sreenan for giving me this opportunity to develop the work in this thesis. This work has not been possible without their endless support, motivation, enthusiasm and patience. I would like to acknowledge that, they are the Best Teachers. Their comments and suggestions helped me a lot in finishing this work. Especially, their discussions.

I would like to thank Dr. Paul Sutton, for his suggestions and motivating questions, which gives me the confidence to move forward in this field. I had a great opportunity to work with Dr. Paul Sutton during my first year.

I would like to thank my Baba and Ami for their endless love and support, who prayed for my success always and are more excited about finishing my degree than me. My lovely wife Rabia, who stayed with me and tried in every way to let me spend my time in studies. My little champ Ibad, discussions with whom is always thought-provoking, and my little princess Hania who tried her best to wake me up early in the morning. I would also like to thank my sisters Ambreen, Saba and Maria and my brother Faizan, for their love and support.

I would like to thank my friends Mubashir Husain, Dr. Zubair Kabir, Jerome Arockiam, Abdul Razak, Waleed Trabelsi, Samreen Umer, Rehan Ahmed, Iftikhar Ali, Junaid Ameen, Ahmed khalid, Imran, Ayaz, Asad, Faisal, Sabir, Raheel, Sajjad and Irfan for their motivation, encouragement and support, and making my time during my studies so wonderful. I would like to thank all my colleagues in Insight Centre and MISL, especially Mustafa, Thuy, Lanny, Jasson, and David for their motivation and questions. I would also like to thank Mufti Naeem Sahib for his prayers and guidance.

I am also thankful to Science Foundation of Ireland for supporting my studies through CTVR, INSIGHT and CONNECT grants.

Abbreviations

3GPP	Third Generation Partnership Project
AASYNC	Asymmetric and Asynchronous
ACHPS	Asynchronous Channel Hopping Prime Sequences
ACK	Acknowledgement
ACS	Available Channel Set
ADC	Analog to Digital
AR	Adaptive Radio
ARCH	Asynchronous Rendezvous Channel Hopping
ASYMM	Asymmetric
ASYNC	Asynchronous
ATTR	Average Time to Rendezvous
BSC	Base Station Subsystem
BTS	Base Transceiver Station
BGAN	Broadband Global Area Network
BL	Blacklisted
BLC	Blacklisted Channels List
BMC	Broadcast Message Centre
CAC	Channel Availability Check
CACH	Cyclic Adjustable Channel Hopping
CAPEX	Capital Expenditure
CCC	Common Control Channel
CDMA	Code Division Multiple Access
CH	Channel Hopping
CNP	Channel Non-Occupancy Period
COLT	Cell on Light Trucks
COM	Communication
COMB	Combinatorial
COMREG	Commission for Communications Regulation
COW	Cell on Wheels
CR	Cognitive Radio
CRCN	Cognitive Radio Cognitive Network
CRBS	Cognitive Radio based Base Station
CRN	Cognitive Radio Network
CSAC	Channel Hopping Sequences based on Available Channels Set

D2D	Device-to-Device
DAC	Digital to Analog Converter
DFS	Dynamic Frequency Selection
DHS	Department of Homeland Security
DNL	Directly Connected Neighbour
DQCH	Dynamic Asymmetric-Role Quorum Based Channel Hopping
DRN	Disaster Response Network
DRS	Disaster Resilience Systems
DSA	Dynamic Spectrum Access
DSAP	Dynamic Spectrum Access Protocol
EARS	Enhancing Access to the Radio Spectrum
ECV	Emergency Communication Vehicles
EJS	Enhanced Jump and Stay
EMCA	Extended Modular Clock Algorithm
EMTEL	Emergency Telecommunications
ES	Estimated State
ETC	Emergency Telecommunication Cluster
ETCH	Efficient Channel Hopping
ETSI	European Telecommunication Standard Institute
ETTR	Expected Time to Rendezvous
EXJS	Extended Jump and Stay
FA	False Alarm
FCC	Federal Communications Commission
FP7	European Framework Program 7
FPGA	Field Programmable Gate Array
FR	Full rate
GCS	Greedy Channel Selection
GF	Galois-Field
GGSN	Gateway GPRS Support Node
GPRS	General Packet Radio Service
GSM	Global System for Mobile Communications
GSMA	GSM Association
HAPS	High Altitude Platform Station
HI	Harmful Interference
ID	Identification
IEEE	Institute of Electrical and Electronics Engineers
IFRC	International Federation of Red Cross and Red Crescent Societies

INL	Indirectly Connected Neighbour
INTER	Intermittent
IP	Internet Protocol
IPICS	IP Interoperability and Collaboration System
ITU	International Telecommunication Union
JS	Jump and Stay
LAN	Local Area Network
LBT	Listen Before Talk
LOS	Line of Sight
LTE	Long-Term Evolution
MAC	Medium Access Control
MCA	Modular Clock Algorithm
MD	Miss Detection
MESA	Mobile Broadband for Emergency and Safety Applications
MIMO	Multiple Input Multiple Output
MMCA	Modified Modular Clock Algorithm
MOS	Mean Opinion Square
MSS	Multi-Radio Sunflower Set
MTTR	Maximum Time to Rendezvous
NAV	Navigation
ND	Neighbour Discovery
NDA	Neighbour Discovery Accuracy
NDR	National Disaster Recovery
NERV	Network Emergency Response Vehicle
NGO	Non-governmental Organizations
NORM	Normal
NS	Network Simulator
NSF	National Science Foundation
NSM	Negative Successful Match
NT	Number Theory
OCHA	Office for the Coordination of Humanitarian Affairs
OFDMA	Orthogonal Frequency-Division Multiple Access
OPEX	Operational Expenditure
OS	Observed State
OSA	Opportunistic Spectrum Access
PBX	Private Branch Exchange
PJR	Periodic Jump base Rendezvous

PMP	Point to Multipoint
PMR	Private Mobile Radio
PPDR	Public Safety and Disaster Response
PR	Primary Radio
PRO	Proactive
PROSE	Proximity services
PSM	Positive Successful Match
PTP	Point to Point
PU	Primary User
QLCH	Quorum and Latin Square Channel Hopping
QoS	Quality of Service
QS	Quorum System
RAN	Radio Access Network
RAND	Random
RCCH	Rendezvous Couple Channel Hopping
REJS	Random Enhanced Jump and Stay
REND	Rendezvous
RLAN	Radio Local Area Network
RQL	Randomized Quorum and Latin Square
RTCL	RTP Control Protocol
RTP	Real-Time Transport Protocol
RWoT	Reactive without Timeslot Truncation
RWT	Reactive with Timeslot Truncation
SASYNC	Symmetric and Asynchronous
SAT	Satellite
SARCH	Symmetric Asynchronous Rendezvous Channel Hopping
SCH	Staggered Channel Hopping
SDR	Software-defined Radios
SECCH	Secure Channel Hopping
SIP	Session Initiation Protocol
SJRW	Sender Jump Receiver Wait
SQCH	Symmetric Role Quorum based Channel Hopping
SSS	Single-Radio Sunflower Set
SSYNC	Symmetric and Synchronous
SU	Secondary User
SYMM	Symmetric
SYNC	Synchronous

TACOPS	Tactical Operations
TETRA	Terrestrial Trunked Radio
TIA	Telecommunications Industry Association
TS	Timeslot
TSF	Telecom Sans Frontier
TTR	Time to Rendezvous
TVWS	TV White Space
UE	User Equipment
UDP	User Datagram Protocol
UMTS	Universal Mobile Telecommunications System
UNICEF	United Nations International Children's Emergency Fund
UNISDR	UN office for Disaster Risk Reduction
USRP	Universal Software Radio Peripheral
VoIP	Voice over Internet Protocol
VSAT	Very Small Aperture Terminal
WAAS	Wide Area Application Services
WCDMA	Wideband Code Division Multiple Access
WCL	Weighted Channels List
WFP	World Food Program
WIDER	WLAN in Disaster and Emergency Response
WiMAX	Worldwide Interoperability for Microwave Access
WMO	World Meteorological Organization
WRAN	Wireless Regional Area Network
XG	Next Generation Communications

Abstract

Disasters are catastrophic events that cause great damage or loss of life. In disasters, communication services might be disrupted due to damage to the existing network infrastructure. Temporary systems are required for victims and first responders, but installing them requires information about the radio environment and available spectrum. A cognitive radio (CR) can be used to provide a flexible and rapidly deployable temporary system due to its sensing, learning and decision-making capabilities. This thesis initially examines the potential of CR technology for disaster response networks (DRN) and shows that they are ideally suited to fulfill the requirements of a DRN.

A software defined radio based prototype for multiple base transceiver stations based cellular network is proposed and developed. It is demonstrated that system can support a large number of simultaneous calls with sufficient call quality, but only when the background interference is low. It is concluded that to provide call quality with acceptable latency and packet losses, the spectrum should be used dynamically for backhaul connectivity.

The deployment challenges for such a system in a disaster include the discovery of the available spectrum, existing networks, and neighbours. Furthermore, to set up a network and to establish network services, initially CR nodes are required to establish a rendezvous. However, this can be challenging due to unknown spectrum information, primary radio (PR) activity, nodes, and topology. The existing rendezvous strategies do not fulfill the DRN requirements and their time to rendezvous (TTR) is long. Therefore, we propose an extended modular clock algorithm (EMCA) which is a multiuser blind rendezvous protocol, considers the DRN requirements and has short TTR. For unknown nodes and topologies, a general framework for self-organizing multihop cooperative fully blind rendezvous protocol is also proposed, which works in different phases, can terminate when sufficient nodes are discovered, and is capable of disseminating the information of nodes which enter or leave a network. A synchronization mechanism is presented for periodic update of rendezvous information. An information exchange mechanism is also proposed which expedites the rendezvous process. In both single and multihop networks, EMCA provides up to 80% improvement in terms of TTR over the existing blind rendezvous strategies while considering the PR activity. A simple Random strategy, while being poorer than EMCA, is also shown to outperform existing strategies on average.

To achieve adaptability in the presence of unknown PR activity, different CR operating policies are proposed which avoid the channels detected with PR activity to reduce

the harmful interference, provide free channels to reduce the TTR, and can work with any rendezvous strategy. These policies are evaluated over different PR activities and shown to reduce the TTR and harmful interference significantly over the basic Listen before Talk approach. A proactive policy, which prefers to return to channels with recent lower PR activity, is shown to be best, and to improve the performance of all studied rendezvous strategies.

Chapter 1

Introduction

Disasters are the unpredictable and unavoidable events which cause loss of life and damage to infrastructure. In the first six months of 2017 alone, a total of 149 disasters occurred in 73 countries, which resulted in 3,162 deaths and more than 80 million people affected, and the loss due to damage was more than 32.4 billion USD [1]. In the second half of 2017, Hurricanes Harvey, Irma, and Maria caused 207 deaths, 6.2 million affected people and losses were more than 110 billion USD [1]. According to the Federal Communications Commission, total 364 cellular sites were damaged out of 7804 (i.e., 4.7%) cellular sites in different counties (in USA) affected by Hurricane Harvey [2]. In some counties, the cell outage percentage was reported as 94.7% and 84.6%, like Aransas and Refugio [2], as shown in Figure 1.1. Disasters cannot be prevented, but their effects and damages can be reduced with proper disaster preparedness and timely response. The preparedness activities include the usage of early warning systems, effective evacuation strategies, disaster resilient infrastructure (including telecommunication) etc. Timely response is also crucial and can be assisted by restoring telecommunication infrastructure in the first 24 hours. In these early hours, the first responders must coordinate their responses, immediate casualties require assistance and all affected citizens may need to access information and contact friends and relatives. Existing access and core infrastructure may be damaged or destroyed so to support the required services new infrastructure must be rapidly deployed and integrated with undamaged resources still in place. This new equipment should be flexible enough to interoperate with legacy systems and heterogeneous technologies. The ability to self-organize is essential in order to minimize any delays associated with manual configuration. Finally, it must be robust and reliable enough to support mission-critical applications.

1. INTRODUCTION

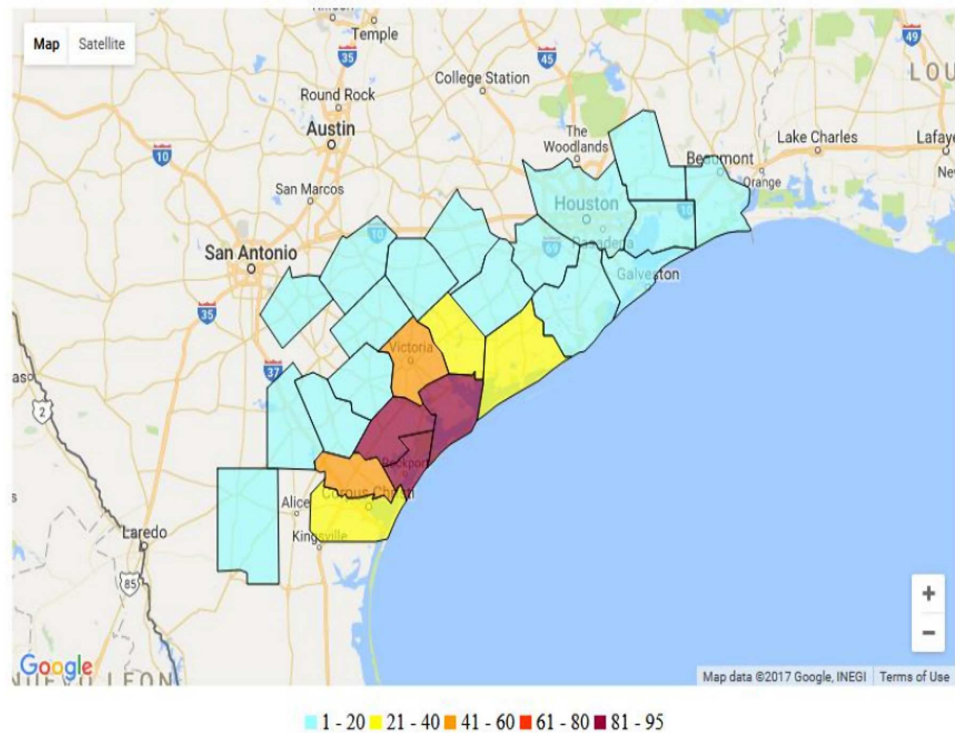

Figure 1.1: Percentage of cell outage due to Hurricane Harvey in August 2017 [2].

Wireless systems can be more easily reconfigured than wired solutions to adapt to the various changes in the operating environment which can occur in a disaster scenario. The existing solutions provided by the service providers to develop an efficient response require pre-configuration of the devices to perform some tasks, and operate with a limited scope or coverage [3, 5]. In disasters, the radio environment remains unknown until explored and physical access may be difficult. An autonomous and rapidly deployable system is required to explore the radio environment and provide timely communication services that must fulfill some unique requirements like rapid deployment, spectrum agility, robustness and reliability, self-organization, interoperability and must provide sufficient quality of service (QoS), to reduce the network setup delay in those crucial early hours of a disaster until a more stable system arrives.

A cognitive radio (CR) is one which can observe its operating environment, make decisions and reconfigure in response to these observations, and learn from experience. It is ideally suited to fulfill the unique requirements of the disaster response network [5]. It can initially sense and discover the available spectrum, explore existing networks in operation, can establish connections with the existing networks and can work autonomously without much supervision, due to its opportunistic spectrum access (OSA) and decision-making capabilities. CR-based flexible systems can be deployed as an autonomous multihop backhaul network to connect two separated cellular

1. INTRODUCTION

base stations or can be deployed to resume the services temporarily while connecting with a nearby survived network, as shown in Figure 1.2. However, to develop an efficient response, this system must fulfill the unique requirements of a Disaster response network (DRN) and must consider real-time deployment challenges, which includes unknown spectrum conditions, difficult physical access, unknown existing networks, and limited power availability.

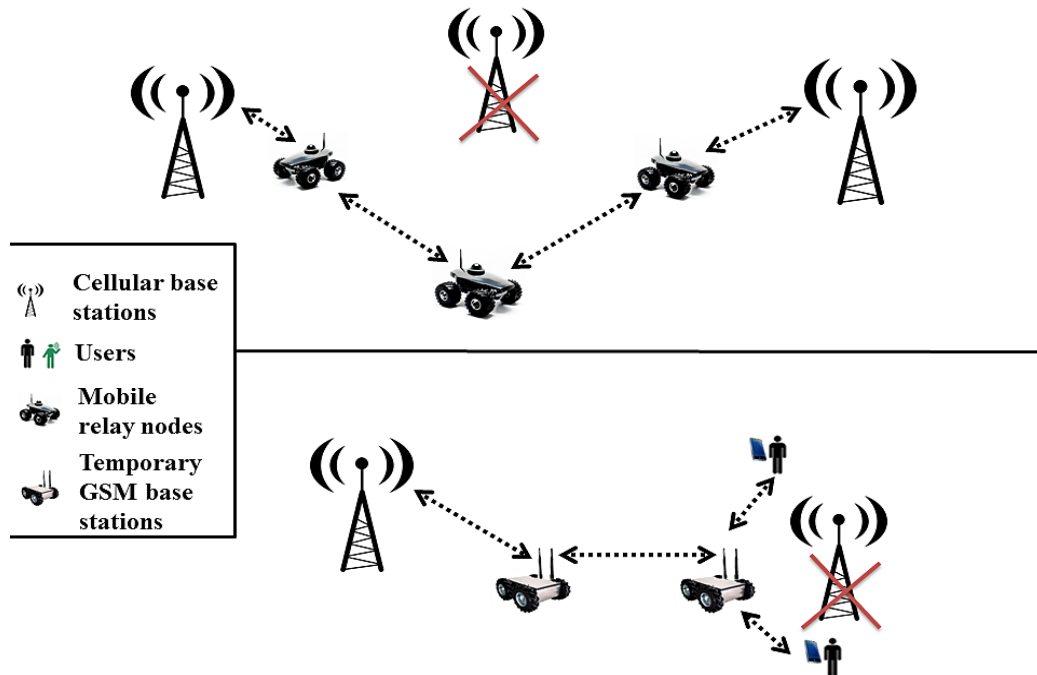

Figure 1.2: Examples of disaster response to restore telecommunication services.

In spite of these deployment challenges, to set up a network, the initial and foremost challenge is to discover the spectrum environment and other nodes i.e., to establish a rendezvous among different nodes. However, establishing a rendezvous among nodes can also be challenging when nodes don't know initially about the available spectrum, channels on which other nodes operate, and the primary radio (PR) occupancy. This, in general, is referred in the literature as a blind rendezvous problem. The existing blind rendezvous protocols are designed to provide a guarantee of rendezvous (under idealised conditions of no PR or interference activity in their channel space), but require long time to rendezvous due to their longer rendezvous cycles lengths (channel hopping length until new parameters are selected to achieve rendezvous) and they do not consider the PR activity. Disasters are special events which makes a rendezvous problem more challenging due to the unknown physical and radio environment. The existing blind rendezvous protocols are not considering a fully unknown radio environment and therefore they can not be directly applicable to DRNs.

The fully blind rendezvous strategy should be able to establish rendezvous among nodes which might not be in the direct range of each other; should be adaptive and self-organizing; should reduce the time to rendezvous to reduce the network set up delay and must not create harmful interference towards the PR system. It also must be able to be aware when to stop and when to start the rendezvous process to accommodate the different nodes entering or leaving the network. They must achieve synchronization among each other to communicate after a rendezvous process is finished to update and disseminate the neighbour information across the network to help establish other network services in a timely manner.

IEEE 802.22 [6] allows a CR to operate on licensed bands if they fulfill some conditions, which includes not to use a channel which is detected with PR activity and to avoid using it for some time. The existing literature on blind rendezvous do not consider these suggestions for CR operation and so its impact is still unknown. The spectrum regulators have already encouraged the use of policy-based radios. These radios can be put in a place to operate under certain conditions and at the same time provide required QoS. They can also be helpful in avoiding some bands completely, (e.g., those used by emergency services) and can also be used to avoid creating the harmful interference by limiting particular channels usage for a short or long time, depending on their PR occupancy. Further, in disasters, any type of PR traffic can be faced by a CR node. Therefore, it must be able to adapt according to it and achieve the design and performance goals.

In this thesis, these issues and concerns are addressed to establish the feasibility of DRN systems together with multihop fully blind rendezvous strategy for disaster environments to establish other network services.

1.1 Thesis Statement

A cognitive radio based fully blind multihop rendezvous protocol with a reactive or proactive operating policy can achieve multi-node rendezvous in unknown environments in the presence of primary radios, which is sufficient to start establishing network services.

1.2 Key Contributions

To address the issues and challenges for establishing network services in an unknown environment, this thesis makes the following contributions,

1. Identification of requirements and challenges for a CR based DRN

The key requirements are identified for a cognitive radio based DRN, based on analysis of the current state of the art disaster response applications, and challenges for satisfying these requirements are specified.

2. A software-defined radio based multihop cellular base station prototype

A software-defined radio (SDR) based multihop cellular base station prototype is proposed and developed. It demonstrates the feasibility of SDR to support services like GSM at the front-end, with enough backhaul capacity to provide sufficient QoS.

3. An Extended Modular Clock Algorithm (EMCA) based blind rendezvous protocol

To address the challenges of deployment, a blind rendezvous protocol is proposed by extending the Modular Clock Algorithm for multiple nodes. As a base case, a single hop network is considered in which each node is assumed to be aware of the existence of all the other nodes in the network and all nodes are within transmission range of each other. Due to known number of nodes, each node knows when to stop or terminate its rendezvous process. However, with this known information, it also considers the unknown channel information at each node and unknown primary radio activity. Although it abandons the rendezvous guarantee, it can improve the rendezvous delay by upto 89% in comparison with existing blind rendezvous strategies under different primary user activity traffic patterns. An information exchange mechanism is also proposed to expedite the rendezvous process together with a handshake mechanism.

4. Cognitive Radio operating policies

Different cognitive radio operating policies are proposed according to the suggestions of the standard bodies to protect the PR systems from harmful interference caused by the CRs. These policies can adapt to unknown primary radio activities, can also reduce the harmful interference, and at the same time can also achieve the design and performance goals by reducing the time to rendezvous.

5. A fully blind cooperative multihop rendezvous protocol

To extend the proposed EMCA (mentioned in contribution 3 for single hop network),

for unknown number of nodes and topologies, a general framework for multihop fully blind rendezvous protocol is proposed which can be applied to any existing rendezvous strategy to work in the multihop environment. As nodes remain unaware of the existence of other nodes in the network initially, it is difficult to know the total number of nodes in the network and so to terminate the rendezvous process. Therefore, each node estimates the total number of nodes by matching its IDs with the sender's neighbour list IDs, and runs until all or a sufficient number of nodes are discovered. A termination condition is also presented in which a node can terminate its rendezvous process when it receives a termination confirmation from all of its one-hop neighbours. This can occur only when two nodes have equal neighbour IDs. The proposed protocol works in a self-organizing manner to start and stop when a new node enters into or leaves the network. It works in a cooperative manner to exchange information between one-hop neighbours to make decisions. A periodic scheduling and synchronization mechanism is also proposed to help nodes exchange rendezvous information without running the rendezvous process from scratch and to establish other network services.

1.3 Thesis Organization

The thesis is organized as follows:

In **Chapter 2**, the current state of the art solutions for disaster response networks are examined and key requirements are identified. The applicability and suitability of using cognitive radio technology for disaster response networks are discussed together with issues and challenges.

Chapter 3 looks at the existing solutions for blind rendezvous with issues and challenges for a disaster response network. The CR operating policies, primary radio activity models and cognitive radio simulators are also discussed.

In **Chapter 4**, a software-defined radio based multihop cellular base station prototype is proposed and its performance is evaluated in an indoor environment.

In **Chapter 5**, an Extended Modular Clock Algorithm is proposed as a blind rendezvous protocol for a single hop network. It is empirically analyzed on different primary user traffic patterns.

In **Chapter 6**, different cognitive radio policies are proposed and incorporated with different blind rendezvous protocols. Their performance is also evaluated over different number of nodes, channels and their blacklisting times.

In **Chapter 7**, a fully blind cooperative multihop rendezvous framework is proposed for an unknown number of nodes and topologies. It is analyzed also over different cognitive radio operating policies, primary user activity patterns and channel blacklisting times.

In **Chapter 8**, the thesis is summarized and future directions are discussed for advancing this work.

1.4 List of Publications

The list of papers which have already been published from this thesis are:

1. Saim Ghafoor, Paul D. Sutton, Cormac J. Sreenan and Kenneth N. Brown, "Cognitive radio for disaster response networks: survey, potential, and challenges," in *IEEE Wireless Communications*, vol. 21, no. 5, pp. 70-80, October 2014.
2. Saim Ghafoor, Kenneth N. Brown and Cormac J. Sreenan, "Experimental evaluation of a software defined radio-based prototype for a disaster response cellular network," *The 2nd International Conference on Information and Communication Technologies for Disaster Management (ICT-DM)*, Rennes, France, December 2015.
3. Saim Ghafoor, Cormac J. Sreenan and Kenneth N. Brown, "Cognitive Radio Policy-based Adaptive Blind Rendezvous Protocols for Disaster Response", *12th EAI International Conference on Cognitive Radio Oriented Wireless Networks (CROWNCOM)*, Lisbon, Portugal, September 2017.

In each of these papers, the present author (Saim Ghafoor) was responsible for all the experimental design, implementation and evaluation, and led the writing of the papers.

Chapter 2

Cognitive Radio Based Disaster Response Network: Survey, Potential and Challenges¹

2.1 Introduction

Disasters are unplanned events which cause significant damage or loss of life. They may also knock out the existing communication networks. The damage to the networks, plus the increased traffic demand, hampers the recovery effort: first responders cannot receive or relay the information they need, victims cannot report their location or request help, and the overall response cannot be coordinated effectively. Quick repair of the communication networks in the critical first period after the disaster could provide a significant boost to the response.

There is a need to rapidly deploy a new flexible infrastructure that can provide immediate services, utilize any existing network resources that are still in place, and interoperate with heterogeneous technologies. The offered system must be reliable and robust enough to support the mission-critical requirements and should be able to self-organize to minimize the delay. Many emerging services based on (2G/3G/4G) mobile systems need to be supported, including different technologies and spectrum bands, each of which may be required in specific locations. In addition, there is a need to discover the extent of the damage: to assess what radio spectrum is available, and what physical access is possible. Obtaining resources to service all of these needs separately, and

¹This chapter was published in IEEE Wireless Communications [5], and is presented here with minor modifications.

coordinating their deployment, is a serious challenge.

A Cognitive Radio (CR) [4] can observe its operating environment, make decisions and reconfigure in response to these observations, and learn from experience. A Cognitive Radio Network (CRN) is formed from multiple CRs, and can adapt network-wide behaviour in response to the environment. CRNs offer support for heterogeneity, reconfigurability, self-organization and interoperability with existing networks, and so offer a promising solution for disaster response. For CRNs to be used effectively, we must understand the requirements, enabling technologies, potential issues and challenges associated with disaster response.

Consequently, in this chapter the focus is on the potential of CR in disaster response for partially/fully destroyed networks. First, an overview of services and requirements is given for a Disaster Response Network (DRN). Secondly, the suitability and potential of using CR technology for DRN is discussed. Finally, the remaining research challenges are discussed.

2.2 Disaster Response Networks

A DRN is a communication network that is rapidly deployed in the aftermath of a disaster, to provide necessary services after existing communications infrastructure has been damaged. A number of different standards, technologies and services are currently used to provide DRNs, and are examined below.

2.2.1 Disaster Response Network Planning

Different Governmental and Non-governmental organizations (NGOs) follow a disaster management cycle which includes a preparedness plan/action, an initial assessment, and an efficient/timely response. A disaster management planning describes the process by which the Governmental and Non-governmental organizations can reduce the losses by taking necessary steps before, during and immediately after the disaster has occurred. The length and order of each step depend upon the intensity of the disaster.

Preparedness Preparedness phase helps in minimizing the effects of a disaster by taking early actions like early warning systems, policies, plans, exercises, evacuation plans and monitoring systems. It requires prior attention to gather the analysis and preliminary actions to avoid and reduce the losses in an expectation of disaster.

Assessment An assessment phase should start during or immediately after a disaster to help assess the area disturbed, the victims in need of help, the ways of transportations and the place to put camps. The network can then be assessed also for any damaged or destroyed networks. It also includes a quick and detailed site survey, the transportation services required for communication services in need, the time required to start a search and rescue operation or deploy a temporary communication network.

Response After the disaster has occurred, the first responders play a major role in providing the immediate response and recovery actions. The first responders can provide immediate help to the victims by initiating a search and rescue operation. In the case of large-scale disaster, they can setup a base camp for connectivity to outside world and can help repair the disconnected or damaged network by putting in devices. In this work, the focus is primarily on the disaster response/recovery networks. Based on the initial assessment, a standalone network can be deployed, a relay network can be put in to connect a disconnected network, or a backbone network can be deployed to serve a particular service with a wider range and accessibility.

2.2.2 Disaster Response Network Requirements

DRN requirements have been examined and outlined by a number of national and international bodies including the US Department of Homeland Security (DHS), the European Telecommunication Standard Institute (ETSI) and the GSM Association (GSMA).

The DHS Program, SAFECOM, has highlighted necessary communication services and their operational/functional requirements for the emergency domain [7]. SAFECOM describes technical requirements for voice/video performance, Quality of Service (QoS), coverage, energy consumption, robustness and recovery.

ETSI have developed a broad range of work programs for Emergency Telecommunications (EMTEL) to ensure the interoperability and interfacing of services and systems in emergency situations. Among these is TR-102-180 which examines requirements for communication from individuals to authorities/organizations in all types of emergencies. Work program TS-102-181 outlines requirements for communication between authorized representatives who can be involved in the responses and actions when handling an emergency. TS-102-182 examines requirements for communications from authorities/organizations to citizens during emergencies. TR-102-485 examines the spectrum requirements of broadband disaster relief communications equipment and TR-102-745 provides an overview of the user requirements for the application of re-

configurable radio systems in the Public Safety and Disaster Response (PPDR) domain. The Mobile Broadband for Emergency and Safety Applications (MESA) project was an international partnership between ETSI and the Telecommunications Industry Association (TIA) which produced technical specifications for mobile broadband technology for PPDR.

The GSMA Disaster Response Program provides a number of resources for mobile operators including an overview of technical challenges and requirements associated with preparing for and responding to disasters. The Third Generation Partnership Project (3GPP) also aims to deliver LTE enhancements for public safety in Release 12, considering requirements for spectrum, regulation, application design, coexistence and migration strategies (VoIP and TETRA). Its two main areas for public safety applications are proximity-based services (SP-120883) and a group communication system enabler for LTE (SP-120876). The inclusion of self-organization capabilities (after Release 8) is relevant to the CR research discussed here.

The key factors and considerations for a DRN are outlined in Table 2.1.

2.3 Existing Solutions

A wide range of DRN solutions are currently in use by national and international disaster response organizations. These include network operators, telecommunications equipment vendors, government agencies and non-government organizations (NGOs). Several United Nations (UN) agencies address the need for communications following disasters including the Office for the Coordination of Humanitarian Affairs (OCHA), the UN office for Disaster Risk Reduction (UNISDR), the World Meteorological Organization (WMO), the International Telecommunication Union (ITU), and the World Food Program (WFP) which leads the Emergency Telecommunication Cluster (ETC). In this section, the existing solutions are examined and their key strengths and weaknesses are assessed.

2.3.1 ETC

The ETC provides vital IT and telecommunication services in the event of a disaster. They aim to provide services (voice, data, and Internet connectivity) within 48 hours of the disaster occurrence. The emergency team uses *fly-away-kits* containing equip-

Table 2.1: DRN Requirements [5]

Requirements	Description
QoS	QoS includes parameters such as availability, throughput, latency, jitter and error rate. DRNs frequently carry mission-critical communications services for emergency first responders and so availability and performance consistency is essential. Depending on the capabilities of the deployed network, these services may include live audio and video streams with strict limits on acceptable performance metrics. For example, VoIP calls may require a guaranteed low bit rate with maximum packet delay of 100 ms, jitter of less than 30 ms and packet loss of less than 1% [8]. When a DRN is deployed, service level guarantees must be put in place based on the available resources and achievable QoS.
Robustness and Reliability	In a disaster scenario, the radio environment may be changing unpredictably, as the communications infrastructure fails or is repaired, as interferers or high priority critical services occupy the medium, and as physical changes block signals. Any DRN should be robust to such changes, and should aim to provide continual coverage. In addition, many of the services being supported may impose extra reliability requirements, including for example, strict latency guarantees on video for remote medical guidance.
Coverage and Mobility	Disasters such as earthquakes, tsunamis and floods frequently affect wide geographical areas. Hurricane Katrina affected an area of 230,000 km ² in the US in 2005. In these situations, disaster response and management personnel require wide-area connectivity to coordinate relief efforts. Handover between adjacent cells and differing wireless technologies may be needed to ensure seamless coverage of the affected area.
Rapid Deployment	Any delay in the response to a disaster may result in further loss of life, injury and damage. DRNs need to be deployed and operational as soon as possible and certainly within first 24 hours following the event to support emergency first responders, permit the affected area to be inspected and assessed and to facilitate the coordination of multiple agencies and authorities.
Interoperability	A DRN may need to link together incompatible communications networks, for example between different groups of emergency responders. Standalone systems can guarantee service availability without relying on the presence of any existing infrastructure in the affected area. However, the capabilities of the DRN and the types of services which it can support may be greatly enhanced by linking into any operational infrastructure which may be available on the ground.
Spectrum Agility	A disaster can occur in any location. In order to be deployable across a wide range of locations and environments, a DRN needs to be capable of operating in a wide range of different frequency bands. With sufficient spectrum agility, a DRN can be deployed without prior knowledge and agreement about what spectrum is in use and by whom. Spectrum agility means a DRN can be adapted to local variations in spectrum use and regulation, making it easier to avoid the creation of harmful interference.
Self-organization	A self-organizing DRN can reduce the need for time-consuming initial configuration. As the operating environment of a disaster area can change unpredictably, the ability of a DRN to self-organize also reduces the need for manual reconfiguration in the event of changes in spectrum availability, network topology, user demand etc.
Cost Effectiveness	More cost effective DRN systems can be made more readily available and deployed more widely. In considering cost, we must look at the cost of establishing and maintaining the DRN system in readiness for use as well as the actual cost of deploying and running that system. In order to provide services rapidly after a disaster, expensive standalone resources can be put in place. However, in the weeks following the event, these expensive solutions must be transitioned to less expensive, more sustainable configurations.

Table 2.2: DRN Capabilities in Existing Solutions Provided by Different Organizations [5]

Organisa- tion/Vendor	Solution	Description	Target Users	Services Provided	QoS	Robustness & Reliability	Mobility	Rapid Deployment	Interoperability	Spectrum Agility	Self-organization	Coverage	Cost Effectiveness
Alcatel-Lucent	Broadcast Message Center (BMC)	Gateway for message delivery to GSM/UMTS/CDMA/LTE networks	Mobile subscribers	Alerts and commercial messages by Network Operators	✓	✓	✓	X	✓	X	X	✓	X
AT&T	Emergency Communication Vehicles (ECVs)	Broadband LAN, Wi-Fi, VoIP connectivity, cellular coverage with backhaul as Microwave radio-link of 5.8 GHz	AT&T team, relief personnel	Voice and data services, communication link with AT&T network	✓	✓	✓	✓	X	X	X	✓	X
	Cell on Light Trucks (COLTs) and Cell on Wheels (COWs)	Portable cell site with satellite backhaul	Relief personnel	Cellular communication	✓	✓	✓	✓	X	X	X	✓	X
Cisco TacOps	Cisco Network Emergency Response Vehicle (NERV)	Satellite WAN link, Wide area application services WAAS, Cisco 1240 Wireless AP, Cisco 1500 Wireless Mesh AP, Cisco 7900, 9900 video phones and 7925 IP phones, Call Manager, Tele Presence for video conferencing, IPICS land mobile radio and video surveillance	Community, Relief personnel, NGOs	Voice, video, data and radio communication, Internet connectivity, video conference and surveillance with satellite backhaul, wide area coverage	✓	✓	✓	✓	✓	X	X	✓	X
Delorme	inReach	A satellite based radio	Community, Relief personnel, NGOs	Positioning and messages	✓	✓	✓	X	X	X	X	✓	✓
Disaster Lab Tech	ICT and Communication Services	Internet services and communication network with satellite link (VSAT)	Limited: Community, Relief personnel, NGOs	Limited: Internet access, Wi-Fi networks, VoIP/VPN services, Humanitarian relief	✓	X	✓	✓	X	X	X	X	X
Ericsson Response	Portable Mobile Communication Network Container	GSM/WCDMA based mobile network	Limited: Relief Personnel, Government organizations	Telecommunication and ICT support	✓	✓	✓	✓	X	X	X	✓	X
	WLAN in Disaster and Emergency Response (WIDER)	WLAN hotspot with VSAT as satellite backhaul	Limited: Relief personnel	Intranet for information transfer, International voice and Internet	✓	✓	✓	✓	X	X	X	X	X
ETSI/TCCA	Terrestrial Trunked Radio (TETRA)	Private Mobile Radio (PMR) System	Public safety organizations, Emergency responders	Voice, Data Communication, Special services (Group calls, Messaging, Broadcast)	✓	✓	✓	✓	✓	X	X	✓	X
GVF	Satellite system	Satellite communication	Community, Relief personnel, NGOs	Voice, data and backhaul connectivity	✓	✓	✓	✓	X	X	X	✓	X
Huawei	eLTE	LTE+ broadband trunking solution	Public safety and Relief personnel	Voice, video and broadband communication, Group calls	✓	✓	✓	✓	✓	X	X	✓	X
Inmarsat	BGAN, Isat Phone Pro	Satellite communication	Community, Relief personnel, NGOs	Voice, data and backhaul connectivity	✓	✓	✓	✓	X	X	X	✓	X
NetHope	Net-Relief-Kit	Solar powered wireless router, ICT and Telecom equipments,	Community, Relief personnel	Humanitarian relief operations with limited ICT services	✓	X	✓	✓	X	X	X	X	X
Telecom Frontier	Sans	ICT and Telecommunication support	Mobile network and WLAN with satellite solutions (VSAT, BGAN)	Local community, NGOs, Relief personnel	✓	X	✓	✓	X	X	X	✓	X
Vodafone Program	Instant	Portable GSM BTS	GSM based network with VSAT as Satellite backhaul	Relief worker and victims	✓	X	✓	✓	X	X	X	✓	✓

ment necessary to establish communications. Other services include staff, asset and vehicle tracking based on UHF/VHF, GSM, satellite and alerting services. For communication services, they provide radio equipment which must be pre-programmed before departure to utilize correct frequency channels for basic coverage around the operational center. This service depends upon prior agreement with a host government and communications regulator for spectrum usage. In data/voice connectivity services, they provide Internet connectivity from a single point, and shared Internet connectivity in cafes/offices for wider coverage. Services are restricted according to the available bandwidth. Dedicated Internet backhaul can be provided via Very Small Aperture Terminal (VSAT) satellite links from the affected area. They assist in providing a dedicated GSM/WCDMA/LTE mobile network to be used by the responders in the disaster area. In information management services they provide information and standards for ICT equipment, lists of GSM providers and availability/reliability of local 2G/3G/LTE data services. ETC provided its initial response for the Typhoon in the Philippines in November 2013 within 24 hours. The emergency communications services provided included Internet connectivity, VoIP, ICT help desk and radio communication around the main operational area. They used Emerging Markets Communication's VSAT services to provide Internet access to WFP staff, with limited use of Broadband Global Area Network (BGAN). A 12 km Internet link between two operational centres was established by using microwave transmitters. Limits in capacity and disturbances in service delivery were observed due to the frequent movement of staff and relief personnel.

2.3.2 AT&T

AT&T's National Disaster Recovery (NDR) program aims at rapid recovery of AT&T's voice and data network in a disaster situation [9]. Its goals are to route telecommunication traffic and to recover communication services. In addition, the NDR team uses mobile satellite communications for humanitarian relief. Their ECVs, COLTs, COWs and technology trailers can be deployed to provide calling services to people in affected areas. ECVs can use satellite links to provide broadband LAN, Wi-Fi and voice (VoIP) connectivity for the recovery site within minutes of arrival with dedicated generators. A 5.8 GHz microwave radio link can also be used to establish communication links from disaster-affected areas to nearby operational sites. A satellite COLT or COW can be utilized to provide cellular communication in areas that have lost coverage due to a disaster. Their technology trailer contains customized telecommunication infras-

structure with inter-/intra-city services. In August 2011, NDR used satellite COLTS to provide cellular services to communities in Vermont and New-York following damaging floods.

2.3.3 Telecom Sans Frontier (TSF)

TSF is the first responders of the UN World Food Program. Since 17 years TSF has been providing the emergency communication services in disaster affected area. Their main aim is to provide response within 48 hours. Initially they start the humanitarian calling operations and then establish the telecommunication centres to help the first responders and also conducts the ICT assessment. These satellite based centres offer internet access, voice communication, fax lines and IT equipment. They rely mainly on satellite based communication system like BGAN, Mini-M, Isatophone-pro and VSAT. TSF's partners in disaster response are mainly UN agencies (OCHA and UNICEF), AT&T, Vodafone foundation, Inmarsat and Eutelsat communications. The deployment phase last until the replacement of core architecture by the government or network operators.

2.3.4 Vodafone Instant Network Program

Vodafone foundation provides services in the area of disaster relief. Vodafone has collaborated with TSF and Huawei to provide an ultra-portable mobile network. It comprises of 4 suitcases, can be carried easily on flights, weighing 100 Kg, can be deployed in 40 minutes and can provide voice and SMS services. Each case contains an antenna, a foldable mast, an industrial computer and a BTS powered by generators. Initially the communication is between the phones in the signal area, but it will take a bit longer to secure the satellite connection for the worldwide connectivity. It also works with WFP and TSF for emergency response. Vodafone mainly aims in deploying mobile technology and volunteers to provide emergency communication and relief.

2.3.5 Ericsson Response Team

Ericsson products are customized container solution for telecommunication and data. It provides the emergency infrastructure and provides the emergency response services.

Ericsson supports the humanitarian organization by its network of volunteers. It provides a GSM/WCDMA mobile network container system, utilized by responders until the original network are restored. It also provides WIDER, a WLAN for emergency response to provide data communication. It uses APs to extend the coverage of camp offices. It works in partnership with UN and International Federation of Red Cross IFRC.

2.3.6 Cisco's Tactical Operations (TacOps)

The TacOps team aims at providing IP based communication to first responders, government agencies and relief organisations. It provides support using rapidly deployable satellite networks, emergency response vehicles and communication kits. It also supports research and innovation in developing standards and long term solutions.

2.3.7 NetHope

NetHope aims at providing the emergency response and humanitarian development. It is working in partnership with Microsoft, Cisco systems, Intel and Accenture. It has developed NetReliefKit a solar powered wireless router in collaboration with Inmarsat to provide internet connectivity through satellite links.

2.4 Discussion on the existing solutions

Table 2.2 lists the main DRN solutions in use today and assesses each according to the requirements outlined in Section 2.2.2. Almost all the service providers claim to reach the site within 48 hours of the occurrence of a disaster, but deployment delays can arise due to the need for prior device configuration, the lack of network damage information, the need for prior government and mobile operators agreement for spectrum utilization and customs clearance. The need here is to deploy flexible, ready-to-use and light weight systems/devices for providing last mile connectivity. For example Vodafone portable BTS can be deployed easily but cannot fulfil the requirements fully as mentioned in Table 1. Almost all listed solutions involve the use of satellite backhaul systems to provide backend connectivity. While this is an effective approach, it is also expensive and there is a need for flexible systems that can switch to lower-cost backhaul connections if and when they become available. Another major problem is the

need for coordination between different service providers and emergency responders. Therefore, to address these issues and to deliver the levels of coordination needed, the future systems must fulfill the unique requirements of a disaster response network.

2.5 Cognitive Radio for Disaster Response Networks

In 1999 Mitola coined the term *cognitive radio* and inspired a wave of research into flexible, reconfigurable wireless systems capable of observing their operating environment, choosing appropriate strategies to achieve specific goals, executing those strategies and learning from past experiences. These capabilities are especially valued in the context of a DRN, where existing communication systems may have been destroyed and new systems must be rapidly deployed in an operating environment about which little may be known and which may change unpredictably. In this section, we discuss the current state of CR technology and open issues.

A CR can change its transmitter/receiver parameters based on interaction with the environment and can make decisions based on the available information and predefined objectives [4, 10]. Figure 2.1 outlines the key mechanisms required by a CR, and indicates their relevance to DRN. All functions operate simultaneously in parallel, each feeding into the other to adapt to changes in the operating environment. Each function is further described below.

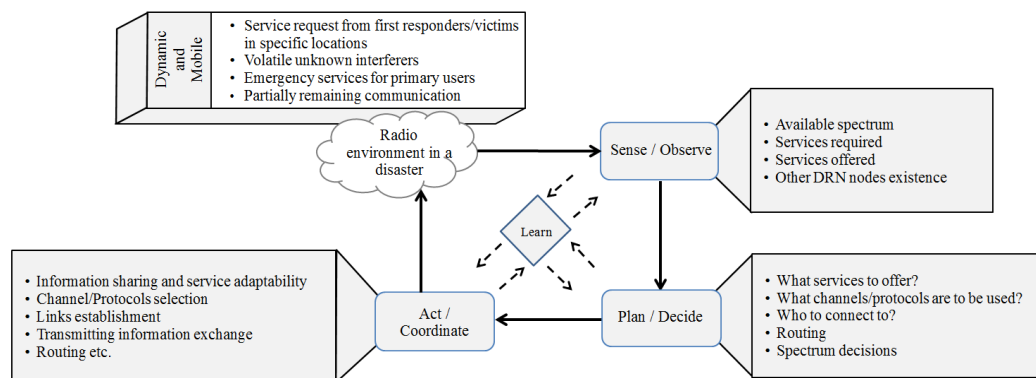

Figure 2.1: Key cognitive radio mechanisms for disaster response network

2.5.1 Sense and Observe

Active neighbouring wireless systems, available spectrum and service requests can be detected and possibly identified by observing the operating environment. Such information can be obtained through local sensing, either independently by individual devices or cooperatively as a network of devices. It can also be obtained via databases, either accessed remotely using a network connection or preloaded and accessed locally on the device. In the context of a disaster scenario, a spectrum occupancy database may not be available or may not reflect the situation on the ground, and so local sensing is expected to play the key role. Observations may be retained to build up a map of the operating environment, to detect patterns and to feedback into the sense/observe process by limiting the search space for future observations.

2.5.2 Plan and Decide

Based on information obtained from the sense/observe process, the CR must then plan a course of action. This may include deciding upon a frequency band to use for establishing network links and choosing an appropriate waveform from a range of available options. For example, a waveform with very low out-of-band emissions may be chosen when operating adjacent to a sensitive wireless system. Alternatively, a waveform with higher out-of-band emissions but lower overhead may be chosen when operating in the absence of neighbouring systems. The decision-making process may be limited to individual radios or it may be a distributed process based on shared observations among them. In the context of a disaster, the CR must decide on which services are to be prioritised, on routing selection for linking heterogeneous systems to existing infrastructure, and on protection for critical services, which can be considered as the primary user of the spectrum.

2.5.3 Act and Coordinate

Once decisions have been made and a plan of action formulated, the CR system must execute that plan by sharing and exchanging information (transmission) and service adaptability. Where the system is commencing operation for the first time, this may involve establishing communication links between peer nodes to form the network and start providing services. In the event that the system is responding to a change in the

operating environment, it may involve sharing information between peer nodes and adapting together to improve the performance of the DRN. Again, the way in which action is taken in the network may be informed by past experience and learned knowledge about the operating environment.

2.6 Cognitive Radio Technology Today

2.6.1 Regulations

Recent years have seen significant developments by regulators to facilitate the deployment of CR technologies. Both Ofcom in the UK and the Federal Communications Commission (FCC) in the US have moved to permit CR systems to operate in TV White Space (TVWS) spectrum following the transition from analog to digital terrestrial television broadcasting. TVWS is the name given to the vacant channels which can be found at different locations due to the frequency reuse patterns adopted by the television broadcast networks. In both the UK and the US, identification of vacant channels is permitted using spectrum sensing or database lookup. Initial power limits and channel detection requirements are quite stringent; however, as stated by Ofcom in their recent consultations, these parameters may be relaxed over time according to the levels of interference experienced. In addition to the UK and the US, regulators in Canada, Singapore and Ireland are also planning to permit the future use of TVWS spectrum by CR systems.

2.6.2 Standardization

As spectrum regulation has evolved to permit the deployment of CR systems, a number of wireless standards for such systems have emerged. Among these are IEEE 802.22, a Wireless Regional Area Network (WRAN) standard for rural broadband using TVWS spectrum, IEEE 802.16h, an extension of the original WiMAX standard to support coexistence among license-exempt systems and *Primary Users (PU)* and IEEE 802.11af, an extension of the popular WLAN family of standards to enable deployment using TVWS spectrum. In addition to these efforts, a royalty-free open standard called *Weightless* [11] has been developed for machine-to-machine communications using TVWS in the UK. Weightless was developed primarily by a company called Neul and

is currently being further developed by a special interest group with more than 1000 members worldwide.

2.6.3 Enabling Technologies

Along with policy changes enabling the deployment of CR systems, technological developments have brought such systems closer to reality. Software Defined Radio (SDR) is the key enabler for CR systems and, in this space, both RF front-end hardware and available software has developed considerably. Highly integrated programmable, wideband RFIC solutions such as the AD9361 from Analog Devices and the LMS6002D from Lime Microsystems have driven the development of highly capable SDR RF front-ends from companies such as Ettus Research (a National Instruments company), Nuand and Fairwaves. On the software side, a number of standards-based solutions for general-purpose hardware have emerged. These include OpenBTS, OsmoTRX, OsmoBTS, OpenBSC and OpenGGSN for GSM and GPRS-based networks. For LTE-based networks, solutions include the LTE100 eNodeB solution from Amarisoft and the OpenAirInterface project from Eurecom. From 3GPP Release 12 and onwards, LTE Device-to-Device (D2D) Proximity Service (ProSe) is added as a part of public safety communication. The objective is to allow devices in close proximity to detect and communicate directly with each other using Sidelinks, to reduce network load and to allow communication in areas without the network coverage [12]. Building upon these technologies are SDR-based companies offering full cellular network deployments such as Vanu, Fairwaves and Range Networks. In the public safety and military domains, the benefits of SDR-based systems have been leveraged by products such as the Liberty radio from Thales and the XG series from Harris, although both radios are reconfigurable but are not compatible with each other.

2.6.4 Research Projects

The European Framework Program 7 (FP7) and U.S. National Science Foundation (NSF) have funded projects on CR and SDR for the disaster response domain. Some of the projects and awards are mentioned in Table 2.3. Overall research on SDR testbeds up to now has focused primarily on Dynamic Spectrum Access (DSA) functionality [13]. Mature, large scale testbeds have not yet been realized in order to fully explore

Table 2.3: Projects Related to Cognitive Radio and Disaster Response [5]

Project	Funding Body	Duration	Objectives
ABSOLUTE	FP-7	2012-2015	The ABSOLUTE project is aiming to deliver the cognitive concepts for dynamic spectrum management by seamless network reconfigurability. Another goal is to provide a rapidly deployable mobile network to provide broadband services.
CORASAT	FP-7	2012-2015	To investigate, develop, and demonstrate cognitive radio techniques in satellite communication systems for spectrum sharing.
CREW	FP-7	2010- 2015	To establish an open federated testbed platform, which facilitates experimentally-driven research on advanced spectrum sensing, cognitive radio and cognitive networking strategies in licensed and unlicensed bands.
EULER	FP-7	2009-2012	To improve the interoperability of civil forces in crisis situations using the benefits provided by software defined radio (SDR).
DITSEF	FP-7	2010- 2013	To provide self-organizing and robust ad-hoc communications where the existing infrastructure is compromised and sensors for overview and threats of the situation.
SALICE	Italy NRF	2008- 2010	To identify the solutions which can be adopted in an integrated reconfigurable NAV/COM device and studying its feasibility in realistic scenarios. The first goal of the SALICE project is to define the baseline scenarios and system architecture for integrated communications and localization techniques, SDR NAV/COM devices, satellite and HAPS integration in the rescue services, heterogeneous solutions in the area of intervention.
EMPHATIC	FP-7	2012-2015	To develop and demonstrate the capability of enhanced multi carrier techniques to make better use of existing radio frequency bands in providing broadband data services in coexistence with narrowband legacy services. Cell based and Ad-hoc based solutions for PPDR will be developed in it.
CNS/EARS	NSF	until 2014	Enhancing Access to the Radio Spectrum (EARS) aims at cognitive and reconfigurable wireless systems. Including spectral efficiency, reconfigurable wireless systems, security of wireless signals and systems, coexistence with legacy systems, special-purpose wireless systems with tests and measurements, economic model for spectrum sharing, spectrum management techniques, network radio architecture and energy efficient and robust spectrum sensing and allocation techniques. Several projects in this scheme are aiming at large scale heterogeneous scenarios.
CNS/RSCRN	NSF	2011-2014	Robust and Secure Cognitive Radio Network project is mainly focusing on coexistence issues of secondary users with primary networks, operating in same frequency bands. It is also focusing on radio resource management schemes and designing low overhead distributed algorithms addressing security issues.

the true meaning of CR as described in [4, 13]. Aspects of the Horizon 2020 Work Programme for 2014-2015 aim to enhance resilience against natural and man-made disasters, including communications interoperability. H2020-DRS-18-2014 focuses on interoperable next generation broadband radio communication systems for PPDR. The scope of this call is to identify and analyse the common communication requirements for PPDR and the gaps in cooperation between organizations in Europe and outside-Europe. H2020-DRS-19-2014 focuses on next generation emergency services for voice/video/data/text communications using 112 products over the Internet. The scope of this call is to gather European emergency services organisations, R&D labo-

ratories and telecommunication-network/VoIP/software/technology providers to build expertise in a collaborative manner.

2.7 Cognitive Radio Potential and Challenges for Disaster Response Network

CR technology is already evolving for use in military and commercial domains. However, many of the capabilities enabled by the technology have significant potential for use in future DRNs. DSA is often considered the key application of CR but there are many other potential ways in which CR can be applied for DRN systems. Currently large scale disaster deployments with dynamic spectrum utilization still needs research [13, 14]. In Figure 2.2, a DRN scenario is shown where NGOs and first responders establish their initial setup in an operation centre. Static/mobile Cognitive Radio Base Stations (CRBSs) can be used to provide the extended voice/data and radio connectivity, with backend connectivity to the operation centre through these CRBS in a multihop manner or with UAVs. The operation centre can be connected to the global Internet via satellite/backhaul links or to other nearby base stations/disaster-sites through multihop CRN.

In a disaster scenario, the DRN is considered as a Secondary User (SU) and the existing/partially destroyed network or any other established first responder services a PU. In this way, it is the responsibility of the newly-deployed DRN to avoid the creation of harmful interference for already-existing systems. Several researchers have highlighted the role of PUs and SUs in a disaster situation, such as [15]. If the SU detects a PU in the course of operation, it reconfigures its operation in order to avoid causing interference. Below, some of the potential benefits of CR in the context of the DRN requirements as outlined in Section 2.2.2 are examined with remaining challenges.

2.7.1 QoS

For a policy-driven CR system, QoS requirements can be used to define those policies. As the operating environment changes, the system may need to adapt to maintain the required QoS parameters. For a disaster scenario, it may be necessary to define multiple service levels which are driven by specific application requirements. In the event

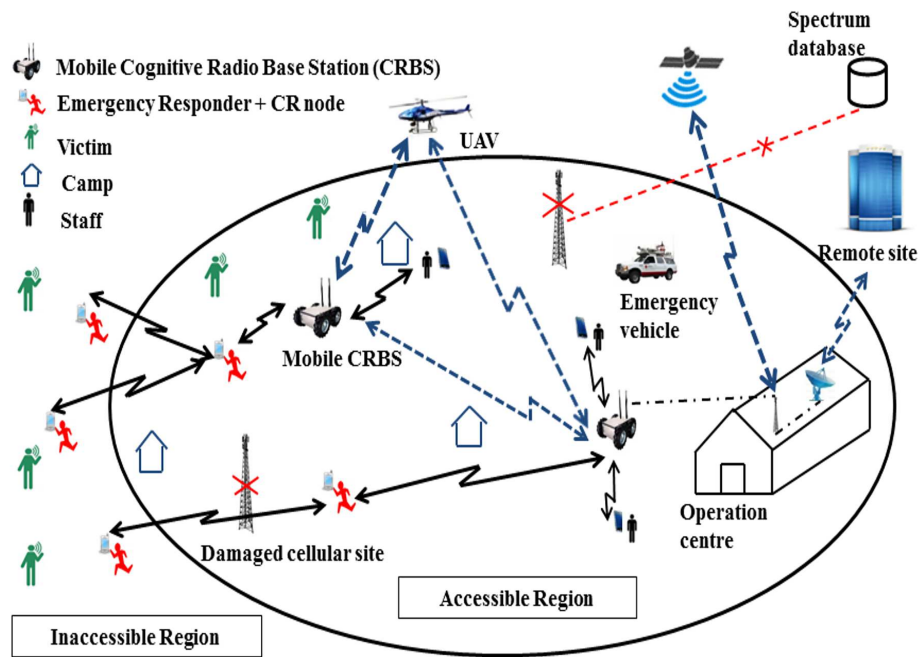

Figure 2.2: Response scenario for an area after communication is destroyed.

that resources are not available to provide a particular service level, the system could then adapt to ensure that the next level is supported. One example of this could be a CR system which operates initially using the UHF band. If the band becomes congested, the achievable throughput might fall below the threshold required for streaming video services. In response, the system might reconfigure to detect a vacant channel, for example in the 2.4 GHz ISM band, and provide services using that channel instead.

To meet QoS requirements, it is important to maintain the level of reliability and end-to-end delay minimization while switching between available spectrum bands [16]. The need for spectrum sensing in a CRN can introduce latency to the network, therefore short sensing times and quick PU detection are needed to reduce the packet transmission delay [17]. If a channel switch is required, the use of pre-arranged backup channels and rapid rendezvous techniques can minimize the delay involved [18]. Such spectrum management mechanisms may involve cross layer solutions.

2.7.2 Robustness and Reliability

CR is ideally suited to provide the robustness required for a DRN. The ability of the system to continually sense its environment and reconfigure to achieve its QoS and

reliability requirements means that it can adapt to the changing environment. Adaptive and efficient transmission techniques with high reliability can be used to avoid link failures. For instance, if a link fails between two mobile nodes due to increasing distance, it can be recovered by changing locations, changing the modulation scheme and switching to a lower frequency with lower path loss.

Further, wideband transmission techniques (frequency hopping, OFDMA, spread spectrum etc.) can also be used to increase the reliability in environments with high interference. A reliable channel can then be selected based on interference, attenuation, shadowing, and fading. To achieve this, higher accuracy sensing is required.

2.7.3 Coverage and Mobility

A CR system could offer an advantage in providing coverage and mobility by acting as the glue to repair a damaged cellular network. Highly-flexible SDR systems can adapt to multiple standards and services using a common radio interface and general-purpose processing hardware. Such systems could replace damaged cellular sites, providing multiple services over e.g. GSM, TETRA, APCO P25, HSPA or LTE. Services could be provided and resources should be allocated according to demand. The same ability to provide multiple different standards and services makes CR an ideal solution for linking together heterogeneous wireless communications systems to ensure coverage of an affected disaster area.

Current DRN communications approaches often target pre-specified areas, resulting in patchy coverage of the disaster scenario. The use of DSA techniques, coupled with multihop network architectures can provide wide area coverage with high bandwidth efficiency as illustrated in Figure 2.2. However, multihop CRNs involve challenges such as spectrum sharing/mobility, optimal relay-node selection, end-to-end delay and interference avoidance [19]. The frequent mobility of CR users affects the topology which relies mostly on the neighbour information. Efficient coordination and spectrum/node selection mechanisms are needed to overcome spectrum availability and service priority constraints. Due to the high cost of satellite based solutions, alternative backhaul solutions and proper channel selection strategies are required [15].

2.7.4 Rapid Deployment

The plug-and-play nature of CR systems can increase the speed with which DRN systems can be deployed. The time needed to configure and tune the network can be greatly reduced by setting a policy for the system and allowing it to operate on the basis of that policy.

CRNs using a DSA approach can use spectrum sensing to build an RF map of the area of operations in order to reduce deployment times [20]. To assess damage and service requirements, emergency personnel can carry auto-configuring CR devices to affected areas in the immediate aftermath of a disaster. These CRs can carry out spectrum sensing and use ad-hoc, multihop and mesh networking techniques [21–23] to relay information using delay-tolerant applications. Following initial assessment, mobile/static CRBSs can be used to extend connectivity and provide services to inaccessible regions as shown in Figure 2.2.

2.7.5 Interoperability

General-purpose RF and baseband processing solutions, coupled with CR techniques including DSA, can offer key benefits when it comes to interoperability. In a disaster response environment different communication systems with different standards and service providers are often deployed, reducing the risks associated with reliance on any single system. However, the operation of these systems in isolation can lead to increased resource constraints and siloing of information. Software radio-based CRs can overcome these issues by providing gateways and bridges between incompatible networks, supporting multiple standards and waveforms in a single device and providing increased service accessibility. Flexible UAV-based interoperable systems offer an additional dimension of connectivity, as illustrated in Figure 2.2.

Many challenges still need to be addressed before such software radio-based CRs can be reliably deployed [24, 25]. However, as discussed in previous sections, technological and regulatory hurdles associated with these systems continue to be overcome.

2.7.6 Spectrum Agility

Spectrum agility is another key benefit of CR technology when applied to disaster response networks. The geographical location of a disaster cannot be predetermined, so DRN systems should not be limited to specific regions. Spectrum regulations can vary greatly between different countries and even within a single standard such as LTE, over 40 different spectrum bands may be used in different regions of the world. Spectrum agile CR systems can adapt to the regulations and spectrum environments of any geographical location. When used to temporarily replace damaged infrastructure, they can replicate the spectrum usage of that infrastructure and when providing independent wireless coverage or relay links, they can avoid the creation of harmful interference using DSA techniques.

Spectrum database-based approaches are emerging as the preferred option for DSA systems in non-DRN scenarios due to the reduced device cost and complexity which they can provide. Database approaches also offer regulators greater control over deployed DSA systems. However, use of a spectrum database requires that database to be in place before a DSA system can be deployed, as well as a reliable communications infrastructure to support access to it. In a DRN scenario, such a database may not exist for the region affected and existing communications infrastructure is often damaged or destroyed. Therefore, spectrum sensing approaches for DSA may be preferred for DRNs. As discussed above, challenges associated with spectrum sensing include minimizing the delay introduced to the network while ensuring sufficient sensing performance to avoid the creation of harmful interference.

2.7.7 Self-organization

The delay-sensitive nature of disaster scenarios demand adapting the spectrum configuration and decision making at runtime to avoid the need for manual configuration of wireless systems and devices. Self-organization can reduce the delays related with deploying and running a network and can decrease operational cost by eliminating the need for manual configuration and maintenance of the network. Self-organizing CR systems with dynamic spectrum management capabilities can provide neighbour/network discovery and node/route selection, requiring fewer specialist technicians on the ground during deployment and operation.

CR systems can provide high spectrum use efficiency and wide area coverage through

Table 2.4: Potential, Issues and Challenges for Cognitive Radio in Disaster Response [5]

DRN Requirements	CR Potential	Issues and Challenges
QoS	<ul style="list-style-type: none"> Adaptability to maintain QoS levels in dynamic environments Policy management based on QoS requirements 	<ul style="list-style-type: none"> Sensing time optimization to minimize packet transmission delay Efficient QoS level switching according to resource availability and application demands Maintenance of end-to-end path reliability
Robustness and Reliability	<ul style="list-style-type: none"> Repeated sensing, parameter selection and reconfiguration Learning from experiences Reliable frequency and robust transmission technique selection 	<ul style="list-style-type: none"> Minimized frequency switching delay in case of failure Algorithms for shorter decision time with accuracy/reliability Spectrum aware routing algorithms for high spectrum variation Collaborative and distributed sensing algorithms Reliable channel assignment and robust transmission strategies
Coverage and Mobility	<ul style="list-style-type: none"> Repair and extend the partially damaged cellular network Support heterogeneous wireless systems and spectrum Wide area coverage using heterogeneous frequencies User mobility support with delay tolerance 	<ul style="list-style-type: none"> Efficient DSA techniques Multihop communication for high bandwidth and wide area coverage Efficient spectrum selection/sharing/mobility mechanisms Efficient coordination among neighbours Optimal relay node selection Maintaining dynamic topology and end-to-end paths due to frequent mobility Coverage extension techniques for last mile connectivity Alternate solutions for backhaul connectivity Delay tolerant mechanisms for sensitive data services (voice, video)
Rapid Deployment	<ul style="list-style-type: none"> Reduced delay associated with device pre configuration and spectrum planning Plug-and-play networks 	<ul style="list-style-type: none"> Ready to use, lightweight CR systems Policy management for operation in critical environments Optimal spectrum utilization with low interference Algorithms for dynamic network topologies (ad-hoc/multihop/mesh) Minimized network/neighbour discovery time Reliability prior to core network replacement/repair
Interoperability	<ul style="list-style-type: none"> Serve as single gateway between different communication systems Flexible resource sharing among heterogeneous networks and spectrum Dynamic bandwidth access/waveform selection Reconfigurability and adaptability of operating parameters Provision of multiple standards and services using a common radio interface 	<ul style="list-style-type: none"> Linking heterogeneous systems while ensuring service accessibility Seamless communication and coordination among different operators and systems PHY/MAC cross-layer design of efficient DSA functions for heterogeneous networks Robust gateway platforms with optimized protocols Network identification for coexistence management
Spectrum Agility	<ul style="list-style-type: none"> Wide spectrum range support Efficient DSA functions for topology management Spectrum utilization based on previous experience Adaptation to region-specific regulations 	<ul style="list-style-type: none"> Spectrum detection techniques for interference avoidance Optimized spectrum sharing techniques Spectrum mobility techniques to maintain QoS levels Disruption tolerance mechanisms Interference minimization and congestion avoidance mechanisms for low packet drop rate Sensing time optimization Advanced interference management techniques
Self-organization	<ul style="list-style-type: none"> Real time system configuration and decision making Reduced manual configuration to minimize the number of technicians on the ground Automatic neighbour/network discovery Reconfiguration and DSA Management to adapt operating parameters 	<ul style="list-style-type: none"> Machine learning algorithms to avoid manual configuration/maintenance Distributed communication techniques with local negotiation Efficient spectrum hand-off mechanisms Optimal route selection in ad-hoc/mesh CRNs Location aware radios, networks and applications for emergency responders
Cost Effectiveness	<ul style="list-style-type: none"> Lower deployment/maintenance costs Multi-standard basestations/gateways Fewer specialists and technicians on ground Less expensive backhaul connectivity 	<ul style="list-style-type: none"> Robust/flexible gateway for multiple services/platforms Mesh networking for low-cost backhaul Low cost inter-/intra-network communication Low cost SDR/CR devices Energy efficient algorithms Protocol optimization to minimize backhaul traffic

spectrum agility over a wide range of frequencies. Self-organization with the network can reduce delays associated with spectrum hand-off, enable coordination among distributed CRs and support local spectrum allocation/sharing negotiations between devices. Decentralized approaches can eliminate single points of failure and increase network robustness.

2.7.8 Cost Effectiveness

Restoration of different services and technologies at the time of a disaster may require the deployment of separate devices for each service. Instead of deploying multiple base stations for multiple technologies and services, deployment of just a single flexible gateway that can fulfil the demands for standards and services can help in reducing the deployment and operational cost. A significant cost associated with DRN systems is due to the use of satellite solutions for access and backhaul. By providing a flexible system which can link into any functional core network resource these costs can be greatly reduced. Alternate backhaul solutions can be provided using CR based mesh networks to connect e.g. surviving base stations.

As discussed in the previous section, self-organizing capabilities can greatly reduce the cost associated with preconfiguring and maintaining a DRN by reducing the need for skilled technicians on the ground. CR based gateway/bridge systems can reduce the cost of establishing and maintaining inter-/intra-network communications.

Table 2.4 further outlines the potential benefits and challenges of CR technology for the disaster response domain.

2.8 Discussion on DRN requirements and challenges

Many of the requirements and challenges identified in this Chapter are addressed in this thesis as follows,

- A Software Defined Radio based Multihop Cellular Base Station prototype is designed and implemented first, which is presented in Chapter 4. The feasibility of SDRs to support the communications services, number of sufficient voice calls with quality and latency, and backhaul communication are analysed. It addresses

the challenges of QoS, Rapid deployment, Coverage, Robustness, Reliability and Cost-effectiveness.

- Based on the conclusions of Chapter 4 and to address the deployment challenges, a blind rendezvous strategy is proposed and analysed in Chapter 5. The aim is to reduce the time to achieve rendezvous, to reduce the network setup delay, in environments with unknown primary user activity. It addresses the challenges of QoS, Rapid deployment and Spectrum Agility.
- To support the policy based cognitive radio operation, different operating policies are presented in Chapter 5, with the intention to further reduce the rendezvous delay and harmful interference with unknown primary user activity. It addresses the challenges of, QoS, Rapid deployment, Adaptiveness, Reliability, Spectrum Agility and Self-organisation.
- For the more general scenario with multiple nodes, a multihop blind rendezvous protocol is presented in Chapter 7. The aim is to reduce the network setup delay, to achieve high neighbour discovery accuracy, and to achieve synchronisation among the nodes. It addresses the challenges of QoS, Rapid deployment, Adaptiveness, Self-organisation, Reliability, Coverage and Spectrum Agility.

2.9 Chapter conclusion

This chapter has described the operational and technical requirements for DRNs and has provided an overview of existing wireless solutions used by emergency response organizations and personnel. CR technology has the potential to be an effective tool for DRNs through the ability to self-organize and adapt operating parameters to the observed environment. In order to realize this potential, many challenges remain to be overcome. These range from robust spectrum sensing techniques to cross-layer spectrum management solutions and from routing protocols for dynamic network topologies to seamless integration of heterogeneous wireless systems. The potential for CR technology for DRN solutions is assessed and key challenges are outlined. By overcoming these challenges, CR technologies can be leveraged to play a prominent role in future mission-critical situations. Therefore, the need to have a rapidly deployable, robust, low cost and light weight solution is justifiable and addressed in the next chapters.

Chapter 3

Literature Review

3.1 Rendezvous

The term rendezvous was first introduced as an optimization problem by Steve Alpern in 1976, in his talk at the Institute of Advanced Studies, Vienna, and later formalised in 1995 [26]. The problems introduced were the strangers meeting in a park and telephone problem. In the strangers meeting problem, two persons who have decided to meet in a park, arrive at different times and entrances and do not know where the other person is. If they both choose to wait by staying at their places, they will never meet. If they both choose to walk, there is an equal probability that they meet or not. If one chooses to walk and other choose to wait, then there is theoretical certainty that they will meet. In the telephone problem, two people in adjacent rooms have a number of phones connected with each other in each room. However, both people are unaware that which phone will be picked at a particular time by the person in the other room. In each problem, the ultimate goal is to find a strategy for each player that could minimize the expected time required for them to meet and to maximize their probability of meeting.

The rendezvous problem inspired real world problems with applications in operational research, applied mathematics, synchronization, operating systems design, neighbour discovery and in search/rescue operations planning. In [27], rendezvous search is discussed with an operational research perspective. In [28], a survey of neighbour discovery and rendezvous strategies is presented for traditional wireless networks and cognitive radio networks. Another survey of rendezvous protocols in cognitive radio networks is presented in [29]. A recent survey on rendezvous protocols for dynamic spectrum management in 5G technology is presented in [30].

In a broad manner, rendezvous is the term used for meeting at a certain place and time. The problem arises when the meeting details are initially unknown.

3.2 Rendezvous in cognitive radio networks

In radio networks, rendezvous is the process by which secondary users or radios establish a link between each other before starting any other network operations. However, until the completion of the rendezvous process, the secondary users remain unknown to each other, even though they are neighbours i.e., they share the same transmission range and have at least one commonly available channel. The process by which they discover or establish a link to communicate with each other is termed interchangeably as Rendezvous or neighbour discovery.

We define the Rendezvous process as the completion of a handshake mechanism between two secondary radios on a single channel, which assumes that the two radios are within transmission range of each other, that they coincide on the channel for a sufficient time period, and that the channel has no detectable primary radio activity or excessive interference for the radios over that time period. It is the first problem in the design of a cognitive radio network on which almost all communications in CRNs rely.

Rendezvous can be achieved by using a common control channel (CCC) by exchanging control packets on a dedicated channel [31]. However, due to the channel saturation problem which occurs when a large number of users use the same channel to transmit control packets, the unpredictable appearance of a primary radio on a common control channel, and vulnerability due to attacks, it can become a single point of failure [31]. To overcome the drawbacks of a common control channel, channel hopping (CH) techniques are used for multichannel and distributed environments. But, they introduce problems like high rendezvous delay and the hidden terminal problem [32]. In a multichannel environment, the sender nodes does not know on which channel the receiver is operating on, and vice versa. Therefore, both sender and receiver can miss the control packets for rendezvous establishment.

When there is no common control channel available and radios are unaware of the channel access sequence of other nodes, this is known as a blind rendezvous problem. A typical application for blind rendezvous protocols is in disasters, where initially the nodes are unaware of other nodes in the network and channels on which they operate. However, all known works considers that nodes are aware of the existence of all the other nodes in the network in advance. Furthermore, the radios are also initially un-

aware of the primary radio activity. Some of the features of a blind rendezvous protocol are,

- rendezvous among all nodes must be completed within a minimum time.
- all neighbours should be discovered.
- all nodes must terminate at the end of the rendezvous process.

3.3 Classification of rendezvous protocols in CRNs

Rendezvous strategies in CRNs can be classified based on single and multiple channels; symmetric and asymmetric channels; synchronous and asynchronous channels; guaranteed and not-guaranteed strategies; centralized and decentralized systems; and different categories [30]. The different categories of rendezvous protocols include number theory (NT), jump-stay (JS), quorum system (QS), galois-field (GF), combinatorial (Comb) and matrix [30]. All these categories are also shown in Table 3.1, together with possible categorization based on disaster response network requirements.

The rendezvous protocols in CRNs are broadly classified as centralized and decentralized protocols. In centralized approaches, a central server is responsible to assign a common control channel to all secondary users (SUs), whereas, in decentralized protocols the central server is not present and so each user or radio is responsible for spectrum sensing, sharing and decision making. In centralized approaches, if the central server is compromised, the whole network operations can be halted. The decentralized protocols are preferable, because of no dependability on a central server. The decentralized protocols can be further classified into a common control channel (CCC) protocols and channel hopping (CH) protocols (i.e., without a CCC or distributed protocols), as shown in Figure 3.1. Channel hopping is a typical technique used for the blind rendezvous, in which each user hops among its available channels to rendezvous with its neighbours.

3.4 Centralized rendezvous protocols

Typical examples of centralized protocols are DSAP [33] and DIMSUMNet [34], which require the server to operate over pre-selected licensed or unlicensed bands (e.g., ISM bands), accessible to all nodes in the network. Although using CCC facilitates communication between the server and the users, it suffers from problems

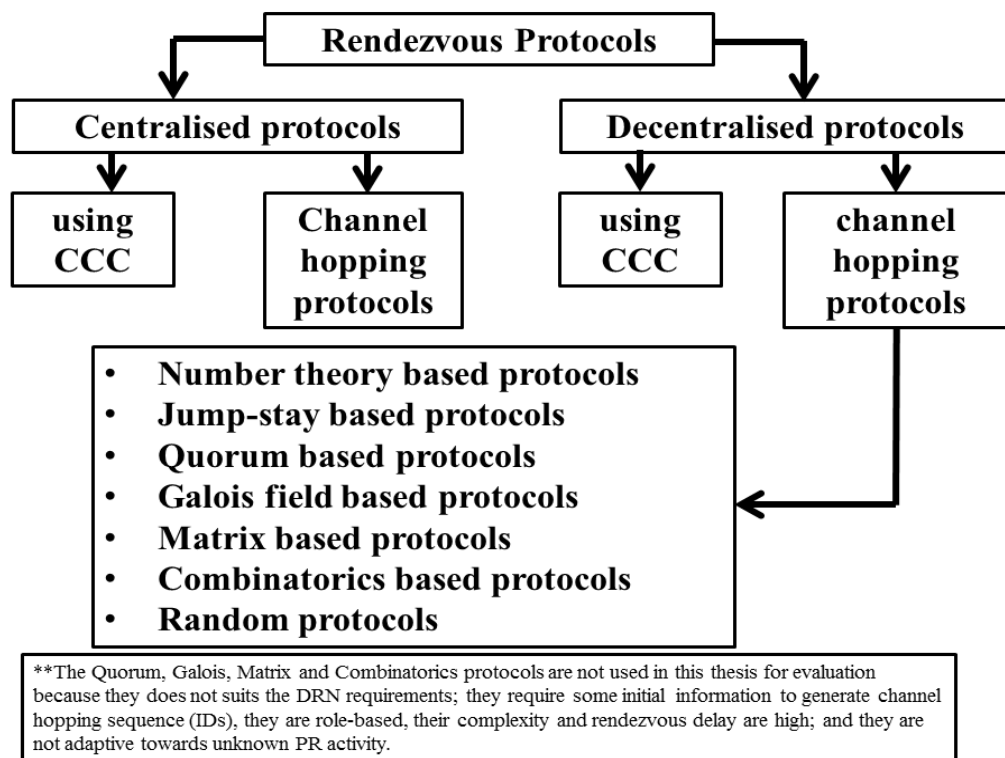

Figure 3.1: Classification of rendezvous protocols in cognitive radio networks.

like channel congestion, difficulty in allocating CCC in licensed bands due to diverse channel availability and vulnerability due to jamming attacks.

In [35], authors discuss a centralized protocol without using CCC, in which an SU search for an available channel and wait on that channel for a long time to expect to meet with the server. The communication between both the server and SU can be established if they select the same available channel.

Although the centralized protocols are fairly easy to implement, they are not suitable for a disaster situation, because of their poor scalability and robustness. Centralized servers also require a database with long-term measurements of each channel. However, such databases might not be available in an event of a disaster. Furthermore, the centralized servers can result in a single point of failure or bottleneck, if the server fails or dedicated CCCs are jammed by malicious attackers.

3.5 Decentralized rendezvous Protocols

The decentralized systems can be further classified into two categories as follows:

3.5.1 Using CCC

The protocols in [36] and [37], assume a global CCC is available, which is obtained in advance and is accessible to all nodes. The nodes can tune to this channel whenever they want to exchange control information. However, due to the dynamic changes in the availability of the channel, it is difficult to use the licensed bands as a global CCC.

In [38] and [39], a cluster-based approach for using local CCCs is presented, in which a local CCC is selected by each cluster group to exchange the control packets. In [38], the authors proposed to use control channels to cover the whole network and argued that the system with fewer clusters is preferable. However, in [39], it is suggested to acquire a proper balance between the number of commonly available channels within a cluster and the cluster size.

Using a dedicated CCC is not easy to maintain in CRNs, because its availability may change over time. If a primary user occupies the CCC for a long time, the control messages can be blocked for a long time. Although an alternate CCC can be used and established, again it depends on the availability. In disasters, where the primary user activity can be unknown, even the alternate CCC can introduce the channel blocking problem. Therefore, the cost of using a CCC can be considerably high i.e., it can become a bottleneck and can cause control channel saturation problem.

3.5.2 Channel hopping protocols

The decentralized protocols without using CCC are mostly referred as the blind rendezvous protocols [28–30], and have attracted significant attention in recent years. They are also referred in general as the channel hopping (CH) rendezvous protocols and can be further classified in different ways, as shown in Figure 3.1. Table 3.1 shows different rendezvous protocols based on the categories and requirements for a disaster response network¹. These schemes are discussed below based on the categories of rendezvous techniques.

¹Self-organize in Table 3.1 means that a rendezvous protocol should work without any initial information of nodes, channels and topology; accommodate the leaving and joining of nodes and decide itself when to terminate and when to restart the rendezvous process.

Table 3.1: Rendezvous protocols in Cognitive Radio Networks

Rendezvous Protocol	Type	No. of users	Single/Multihop	Symm/Asymm Chs	Synch/Asynch	Reud guarantee	Role based	Simulator	PR activity	Reud guarantee with PR activity	Adaptive towards PR activity	Policies	Self-organize	Unknown nodes	Unknown topology
MCA [40]	NT	2	Single	Symm	Asynch	✓	X	custom	X	X	X	X	X	X	X
MMCA [40]	NT	2	Single	Asymm	Asynch	X	X	custom	X	X	X	X	X	X	X
CSAC [41]	NT	2	Single	Asymm	Asynch	✓	✓	Visual C	X	X	X	X	X	X	X
Ssync [42]	NT	Multi	Single	Symm	Synch	✓	✓	Omnet++	✓	X	X	X	X	X	X
SASync [42]	NT	Multi	Single	Symm	Asynch	✓	✓	Omnet++	✓	X	X	X	X	X	X
AASync [42]	NT	Multi	Single	Asymm	Asynch	✓	✓	Omnet++	✓	X	X	X	X	X	X
SCH [43]	NT	Multi	Single	Symm	Asynch	✓	X	Java	✓	X	X	X	X	X	X
RCCH [44]	NT	Multi	Single	Asymm	Synch	✓	✓	NS-2	✓	X	X	X	X	X	X
ARCH [44]	NT	Multi	Single	Asymm	Asynch	✓	✓	NS-2	✓	X	X	X	X	X	X
SARCH [44]	NT	Multi	Single	Symm	Asynch	✓	X	NS-2	✓	X	X	X	X	X	X
SUBSET [45]	NT	Multi	Single	Symm	Asynch	✓	✓	custom	✓	X	X	X	X	X	X
2-PRIME [46]	NT	Multi	Single	Asymm	Asynch	✓	X	custom	X	X	X	X	X	X	X
EVCS [47]	NT	Multi	Single	Symm	Asynch	X	✓	C++	✓	X	X	X	X	X	X
PSA [71]	other	Multi	Single	Symm	Asynch	X	X	custom	✓	X	X	X	X	X	X
JS [48]	JS	Multi	Both	Both	Asynch	✓	X	custom	X	X	X	X	X	X	X
EJS [49]	JS	Multi	Both	Both	Asynch	✓	X	custom	X	X	X	X	X	X	X
PJR [55]	JS	2	Single	Both	Asynch	✓	✓	custom	X	X	X	X	X	X	X
AR [50]	JS	Multi	Single	Both	Asynch	✓	X	Matlab	X	X	X	X	X	X	X
SJRW [51]	JS	Multi	Both	Both	Asynch	✓	✓	custom	X	X	X	X	X	X	X
AEHW [52]	JS	Multi	Single	Asymm	Asynch	✓	X	C	X	X	X	X	X	X	X
EREJS [54]	JS	Multi	Single	Asymm	Asynch	✓	X	custom	X	X	X	X	X	X	X
RQL [56]	QS	Multi	Single	Symm	Asynch	✓	✓	NS-2	✓	X	X	X	X	X	X
DQCH [57]	QS	Multi	Single	Asymm	Asynch	✓	✓	custom	✓	X	X	X	X	X	X
SQCH [57]	QS	Multi	Single	Asymm	Asynch	✓	X	custom	✓	X	X	X	X	X	X
QLCH [58]	QS	Multi	Single	Symm	Synch	✓	✓	NS-2	✓	X	X	X	X	X	X
SYNC-ETCH [59]	QS	Multi	Single	Asymm	Synch	✓	X	NS-2	✓	X	X	X	X	X	X
ASYN-ETCH [59]	QS	Multi	Single	Asymm	Asynch	✓	X	NS-2	✓	X	X	X	X	X	X
CR-RDV [61]	QS	Multi	Single	Asymm	Asynch	X	X	Matlab	X	X	X	X	X	X	X
CACH [62]	GF	Multi	Single	Symm	Both	✓	X	C++	✓	X	X	X	X	X	X
ACHPS [63]	GF	Multi	Single	Symm	Asynch	✓	X	custom	X	X	X	X	X	X	X
SEC-CH [64]	Matrix	Multi	Single	Asymm	Asynch	✓	X	custom	✓	X	X	X	X	X	X
TRI-CH [64]	Matrix	Multi	Single	Asymm	Asynch	✓	X	custom	✓	X	X	X	X	X	X
T-CH [66]	Matrix	Multi	Single	Asymm	Asynch	✓	X	NS-3	✓	X	X	X	X	X	X
D-CH [66]	Matrix	Multi	Single	Asymm	Asynch	✓	X	NS-3	✓	X	X	X	X	X	X
SSS [67]	Comb	Multi	Single	Asymm	Asynch	✓	X	custom	X	X	X	X	X	X	X
GCS [68]	other	Multi	Both	Asymm	Synch	✓	X	C++	X	X	X	X	X	X	X
AMRCC [69]	RAND	Multi	Single	Symm	Synch	X	X	Matlab	✓	X	✓	X	X	X	X
M^2HEW [70]	RAND	Multi	Single	Symm	Both	✓	X	X	X	X	X	X	X	✓	X

3.5.2.1 Number theory based Protocols

Modular Clock Algorithm (MCA): In [40], an MCA based channel hopping algorithm is presented for symmetric channels, which is a blind rendezvous algorithm. It is based on results from number theory, and it uses: a rate r_i which is the step length by which a node i jumps from one channel to another; an index j_i which is the channel index (label); and p_i which is the smallest prime number greater than or equal to m_i (the total number of available channels). The algorithm begins by selecting an initial index value j_i randomly. In each timeslot t_i the index value is increased by $r_i \bmod(p_i)$. The rate r_i is picked randomly out of $[0, p_i)$ initially and remains same until the rendezvous cycle ends, which is equal to $2p$ timeslots. However, if rendezvous does not occur during a full cycle length then only a new rate value will be selected. If the channel index value is within $[0, m_i)$, that channel is selected by the radio, otherwise the index will be remapped using the \bmod function between 0 and $m_i - 1$, which occurs due to the gap between the m_i and p_i . In MCA, rendezvous between two nodes is guaranteed only when both nodes pick their rates (r_i) differently. The $2p$ timeout value after which r_i changes is to ensure that each radio has spent $2p$ timeslots on the same rate, which guarantees the rendezvous (only when $r_1 \neq r_2$).

An example of index calculation and channel selection is shown in Table 3.2 and Figure 3.2. Each node selects an initial index and a rate value randomly and calculates current timeslot index value using formula $(j+r \% p)$. The channel at the resulting index values is then selected to attempt a rendezvous. At the first timeslot, the resulting index value is 3 (Table 3.2), the channel at 3rd index of node 1's available channels set (ACS) is 4, as shown in Figure 3.2. Similarly, node 2 selects channel 3. At the 3rd timeslot or attempt both nodes select channel number 2, and can exchange beacons with each other.

Modified Modular Clock Algorithm (MMCA): MMCA is presented in [40] for the individual channels case in which each node can have different channels. It works similar to MCA, but with longer rendezvous cycle length (i.e., $2p^2$) and random replacement of unavailable channels within $[0, m_i)$. In [40], under the individual model (asymmetric channels), rendezvous between two nodes cannot be achieved when they both pick the same prime number. To help avoid such cases, prime numbers are selected randomly within $[m_i, 2m_i]$.

Channel-Hopping sequences based on Available Channels Set (CSAC) : A rendezvous protocol which generates channel hopping sequences based on the ACS is presented in [41], where the ACS represents a set of channels on which a node can

Table 3.2: Example of Modular Clock Algorithm

	initial index (j_i^t)	rate (r_i)	prime number (p_i)	current channel index $j_i^{t+1} = (j_i + r_i) \% p_i$	selected channel (c_j)
Node 1	1	2	5	$(1 + 2) \% 5 = 3$	4
		2	5	$(3 + 2) \% 5 = 0$	1
		2	5	$(0 + 2) \% 5 = 2$	2
Node 2	3	4	5	$(3 + 4) \% 5 = 2$	3
		4	5	$(2 + 4) \% 5 = 1$	4
		4	5	$(1 + 4) \% 5 = 0$	2

Available channels set of each node.

$$ACS_1 = \{1, 3, 2, 4\}$$

$$ACS_2 = \{2, 4, 3, 1\}$$

Selected channels in each timeslot using MCA.

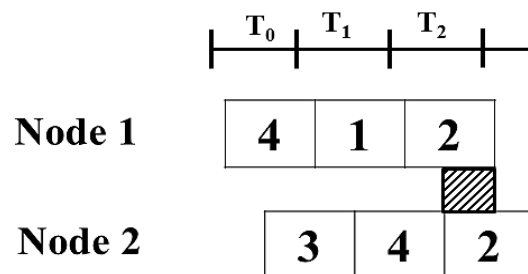

Figure 3.2: ACS and selected channels using Modular Clock Algorithm.

communicate with others without interfering with the primary radio. It is argued that using available channels set is more beneficial than using the whole channels set to avoid unnecessary rendezvous attempts. However, the channels in the ACS are assumed as free all the time, which is an unrealistic assumption as a primary radio can occupy again these channels at any time. CSAC is a blind rendezvous algorithm, which guarantees the rendezvous when number of channels n is not divisible by m_p (a smallest prime number greater than n). However, it is a role-based rendezvous algorithm, where roles of sender and receiver are fixed and both generate their CH sequences in rounds using a prime modulus. In real environments, where even the nodes information is not available, such a role-based assignment cannot guarantee the rendezvous when two nearby nodes are assigned the same roles.

Symmetric Synchronous and Symmetric/-Asymmetric Asynchronous CH algorithms (SSync, SAsync and AAsync): In [42], three different CH protocols are proposed, namely SSync, SAsync, and AAsyn. The proposed protocols are designed for homogeneous (SSync and ASync) and heterogeneous (AAsync) environments. These protocols use the primitive roots of a prime number to generate channel hopping sequences, and are calculated based on the number of available channels. The default sequence is chosen by using the largest primitive root and an elementary sequence is chosen by using a primitive root which can get a maximum degree of overlap with the default sequence. These default and elementary sequences are then used for generating the channel hopping sequence of a sender and a receiver. Although, the rendezvous guarantee is provided when hopping sequences are within a bounded range and primary user activity is also considered. But, the proposed protocols require pre-assignment of roles as a sender and receiver. The applications of role-based node assignments are limited, as a node cannot work as a forwarder. Further, the guarantee cannot be achieved if two unknown nodes have same roles.

Staggered CH Scheme (SCH) : In [43], an SCH protocol for asynchronous timeslots with symmetric channels is presented, which is based on the Chinese remainder theorem. Mainly, it uses the concept of triplets to adjust the ratio of using channels in a staggered way. The channel hopping sequences and the number of slots in a frame is determined by the generated combined triplets. A triplet is denoted by $(p_1, p_2, c_1/c_2)$ i.e., two primes and a ratio, where primes are selected over M (the total number of channels) in an increasing order (as $p_1 \leq p_2$). For using a channel i , out of M , a target ratio which is assigned by a triplet as $1/p_1$ or $1/p_2$, is used. The guarantee is claimed when two nodes select different prime numbers, but without the PR activity consideration. In this scheme, only symmetric channels are considered, however in real environments the channel at each node can be different. The PR activity is considered,

however the time to rendezvous increases with increase in the PR activity.

RCCH, ARCH, and SARCH: In [44], three different CH rendezvous protocols are presented which are the Rendezvous Couple CH protocol (RCCH), the Asynchronous Rendezvous CH protocol (ARCH) and the Symmetric Asynchronous Rendezvous CH protocol (SARCH). These protocols are designed for both synchronous/asynchronous and symmetric and asymmetric environments. Both RCCH and ARCH requires the pre-assignment of roles. The main idea is to generate CH sequences based on a seed and the directions as clockwise or counter clockwise to achieve rendezvous. Two nodes which hop channels in the same direction can never meet; however, if both hops channel in different directions they can meet with each other. In these protocols, it is required that the potential CH sequences which include that sender and receiver's initial channels should be of same parity (i.e., even or odd channels), the CH direction should be distinct and the total number of channels and seed values should be co-prime. Further, if the sender CH sequence is even-time-parity (i.e., it selects even channel at even timeslot) and receiver's sequence is odd parity, then rendezvous cannot occur. To overcome this, it is proposed to generate alternate even and odd parity CH sequences at the sender. The SARCH is designed for symmetric and asynchronous environments in which the CH sequences are constructed using the default initial channel and CH seed and does not require pre-assignment of roles as a sender or receiver. Although, the designed protocols are based on channel hopping, these CH protocols require some initial information to generate the CH sequences and to achieve rendezvous. Primary user activity is also considered but the designed protocols are not adaptive to the unknown PR activity, and therefore can not be used for a disaster environment, as can increase the network set up delay.

SUBSET: A role-based channel selection and hopping blind rendezvous design is presented in [45]. It is argued that increasing the number of channels can increase the TTR also. The rendezvous is guaranteed in fewer timeslots when the available channel set of a receiver is selected as a subset of the sender's available channel set, which is selected by placing the SUs close to each other and limiting their transmission power. Due to the nearby placement of SUs, the PR activity is considered as evenly distributed among different SUs. However, in disasters due to unknown channels and node information, such channel sequences cannot be guaranteed. Further, it is a role-based rendezvous scheme, in which the rendezvous guarantee can not be achieved when two nodes select the same roles and are close to each other.

Two prime modular clock algorithm: In [46], a two-prime modular clock algorithm is proposed for two users rendezvous problem together with utilizing user IDs for help-

ing rendezvous and generating CH sequences. In this protocol, each user generates M 0/1 sequences according to M -bit codeword of their user IDs. The rendezvous guarantee can be achieved when two users pick different prime number-based sequences within $M_{max}[p_{i,0}p_{j,1}, p_{i,1}p_{j,0}]$. However, for sequence generation, the Modular clock algorithm is used with similar rendezvous cycle length. It is also extended for multiple users by using a leader election mechanism, where leaders are elected based on the smallest number of channels among nodes and using unique IDs when a number of channels is equal between two nodes. The users then follow the channel sequences and timings of the leader in that group. The expected time to rendezvous for the two-prime algorithm is shown as same with the Random algorithm. The primary user activity is not considered which can result in the loss of the guarantee.

3.5.2.2 Jump-stay based CH protocols

Jump-stay (JS): The JS is influenced by MCA and uses the same modular arithmetic approach. It is a blind rendezvous CH protocol [48], in which each user generates their channel hopping sequences in rounds. Each round consists of a jump pattern in which a user hops over the available channels based on the rate (the jumping factor) and a stay pattern in which a user stays on a particular channel for some time. The inner round's cycle length is $3p$ timeslots, from which $2p$ timeslots are assigned to the jump pattern and p timeslots are assigned to the stay pattern. It is guaranteed that two users can rendezvous within $3p$ timeslots, but only when they pick their rate values differently. It is also extended to multiuser and multihop scenarios, but users with lower IDs follow the channel hopping sequence of users with higher IDs. However, it cannot be directly applied to a disaster scenario, because it is not designed to handle the unknown primary radio activity and an unknown number of nodes. An extension of JS protocol is presented in [49], which improves the maximum time to rendezvous (MTTR), but at the cost of longer rendezvous cycle length that is $4p$ timeslots. An adaptive rendezvous (AR) strategy for JS-based channel hopping is proposed in [50] using multiple radios in which channels are equally divided among three interfaces according to their noise level.

Sender-Jump Receiver-Wait (SJRW): In [51], a role-based blind rendezvous protocols is proposed for CRNs, in which a sender hops among the available channels and stays for T timeslot duration while a receiver waits for $M.T$ times on a particular channel to achieve rendezvous. It is an asynchronous protocol designed under symmetric and asymmetric channels with multiuser and multihop support. In the multihop approach, a user with a smaller number of channels will follow the synchronization and

hopping sequence of a user with a higher number of channels. It provides the guarantee when the number of channels of one user is smaller than the other. However, primary user activity is not considered, and nodes are aware of the total number of nodes in the network.

Extensions of EJS and REJS: In [53], Enhanced JS [49] and Random Enhanced JS (REJS) [54] (which is designed for mitigating the jamming attacks over JS) are proposed by introducing random channel assignments in the algorithms, to improve the average time to rendezvous. The random replacement of channels which appear higher than P (a prime number greater than m , the total number of channels) is proposed for both EJS and REJS. Random is shown as mostly performing better due to its better ETTR $m_1 \times m_2 / M$ than the ETTR of EJS. Further, it is shown that the performance of Random algorithm is dependent on G (the number of common channels) and it move towards the performance in symmetric channels when G will increases, whereas in symmetric channels case the performance of Random algorithm is found to be worst, as also shown in [40].

A periodic jump-based rendezvous algorithm (PJR): In [55], a blind rendezvous problem is addressed for CRN by using a role-based solution through constructing channel hopping sequences. An enhanced version of PJR is also proposed, in which nodes randomly pick their initial role. The PJR is guaranteed to provide rendezvous within $(C + 1)^2$ for even number of channels and C^2 for an odd number of channels, where C represents the total number of channels.

3.5.2.3 Quorum based CH protocols

Randomised Quorum and Latin square CH protocol (RQL): A distributed CH protocol RQL is presented in [56], which uses the concepts of Quorum system, Latin Square and Pseudo-random number generator. The quorum system is used to guarantee rendezvous, Latin square is used to spread rendezvous over all channels and Pseudo-Random number generator is used to increase channel utilization. The Quorum system Q is mainly a collection of non empty subsets of a universal set U . A Latin square is an $n \times n$ matrix of order n , which contains n elements, where each element occurs exactly once in each row and column. Pseudo-random number generator is an algorithm which generates a sequence of a number by approximating the properties of a random number. The channel hopping patterns are generated using these three methods. However, the drawback is that each secondary user needs to know the identifiers and timeslot offset of its neighbours to switch to any global channel. The roles are picked randomly.

Asymmetric and Symmetric Quorum based CH protocols (DQCH and SQCH):

Two quorum-based CH hopping protocols based on asymmetric and symmetric roles of secondary users are proposed in [57] for asynchronous environments. The drawback of DQCH is that it assumes the pre-assignment of roles of secondary users as a sender or receiver. In a distributed environment, this assumption is not realistic as nodes may not even know about the existence of other nodes in the network. It also uses different methods for channel hopping sequence generation for sender and receiver. Since SQCH does not require pre-assignment of roles and generates channel hopping sequences using the same method, it is more practical. However, the randomly replaced channels are copied in different sub-columns to increase the rendezvous success rate which is a biased condition as all channels might not be same among different nodes.

Quorum and Latin square based CH protocol (QLCH): In [58], a CH hopping protocol based on Quorum and Latin squares is proposed. The proposed protocol provides the rendezvous guarantee when the sender and receiver pick the same row of channel hopping sequence generated by Quorum system and Latin squares. In QLCH, the secondary users use different CH schemes for receiver and sender. The cyclic Quorum system is used to provide balanced rendezvous guarantee among different users and Latin squares is used to share such rendezvous among users. As in RQL [56], the drawback is that it requires the user ID information and timeslots offsets of other nodes in advance to generate CH sequences of all neighbours. Moreover, it is designed for synchronous CRNs, in which roles are also pre-assigned. It is similar to the CH protocol presented in [56] (RQL), the only difference is the use of pseudorandom number generator in RQL.

An efficient CH protocol (ETC): In [59], two efficient CH protocols are proposed for synchronous and asynchronous timeslots (i.e., Sync-ETCH and Async-ETCH). The Sync-ETCH uses two-phase and single-phase generation of CH sequences. In two-phase, it schedules the rendezvous in advance and then based on the schedules it generates CH sequences, whereas in single-phase it generates CH sequences using Quorum system and starts hopping on channels. In an unknown environment, where little may be known about the nodes and channels, such schedules cannot be decided in advance. The Async-ETCH follows Sequential channel hopping presented in [60], however, both protocols assume global channels which are accessible by all nodes.

3.5.2.4 Galois-field based CH protocols

A cyclic adjustable CH scheme (CACH): In [62], CACH protocol is proposed for symmetric channels and synchronous timeslots, which is not suitable for distributed and unknown environment, as it is difficult to achieve time synchronization among different secondary users. For symmetric channels and asynchronous timeslots, a *wait for mommy* approach is shown as an optimal solution. For both protocols, it is assumed that all channels are accessible and can be used for rendezvous at each node, which is not a practical assumption. It uses Galois-field approach to generate CH sequences, where Galois-field or $GF(N)$ is a set of N elements with addition and multiplication operations that satisfies various algebraic properties [62].

Asynchronous CH prime sequences (ACHPSs): In [63], an asynchronous symmetric CH sequences based protocol is proposed. The main idea of ACHPS generation is to concatenate p shifted prime sequences in a way that the number of cyclic shifts in the prime sequence of every CH sequence follow the patterns created by a series of modulo p multiplication. However, each secondary user is limited to select a prime sequence from the same group and it is assumed that channels are always available for all secondary users, which is an unrealistic assumption. In real environments, the available channels might not be available at the next time instance due to PR activity. The secondary users utilise the distinct prime sequences from the same group, which is also unrealistic in a distributed environment, as nodes remain unaware initially about the sequences used by the other users until they achieve rendezvous with each other.

3.5.2.5 Matrix based CH protocols

Anti-Jamming CH Scheme (Sec-CH): In [64], a secure anti-jamming CH scheme is presented, in which CH sequences are generated by secondary users using their ID string and available channels set in the form of a matrix. The CH patterns are randomly assigned to Jump and Stay patterns. It provides bounded time to rendezvous, but the guarantee of rendezvous is provided only when the sender is in Transmit mode and receiver is in Receive mode. The length of jump pattern in Sec-CH is $2N$, where N is the number of channels and therefore the maximum time to rendezvous is long. The modes of operation are not pre-assigned but are chosen randomly to achieve the rendezvous. However, any attacker which receives the ID can generate the similar CH sequences. A similar approach for generating CH sequences and reducing the maximum time to rendezvous is presented in [65].

TCH and DCH CH algorithms: Two CH protocols, TCH and DCH are proposed in [66], both are matrix based and generates channel hopping sequences for random jump and stay modes. In both protocols, the roles of the nodes are not pre-assigned. However, the modes are randomly assigned based on which a node can transmit or stay silent for a period of time. TCH does not require the ID information but assumes the global channels as a prime number, which is an unrealistic assumption. The DCH protocol requires the ID information and uses the ID bits to generate different CH sequences for the jump mode and stay mode, which is not a secure strategy.

3.5.2.6 Combinatorial based CH protocols

Single Radio Sunflower Sets (SSS): In [67], mathematical construction of sunflower sets are used with a single radio to achieve pairwise rendezvous. An approximation algorithm is also presented to construct disjoint sunflower sets to adjust the order of accessing channels. The accessed channel label is achieved through the index of sunflower set which also contains the timeslot number. A multi-radio sunflower set (MSS) is also proposed to improve the rendezvous diversity and speed up the rendezvous process.

A greedy channel selection (GCS): In [68], a greedy channel selection algorithm is proposed for single and multihop CRNs. It also proposes a message passing based strategy to expedite the rendezvous process which includes channel switching order. All nodes start their rendezvous process at the same time and with default channel hopping sequence. When a node encounters a rendezvous with any other node, it will start following the channel hopping sequence of the other node, if the identifier is smaller than its own identifier (user ID) (assumes IDs are ordered). It assumes a global channels are accessible to all users, which is an unrealistic assumption as some channels might not be available to some nodes. It is possible that after a node starts following the channel hopping sequence of the other node, some channels might not be available or occupied by a primary radio. A guarantee of rendezvous is provided only for cases where there is no other PR or interfering activity on the channels. The protocol for multihop is also given but for a known number of nodes.

3.5.2.7 Random CH protocols

In random channel hopping protocols, each user selects a channel in a purely random manner from its available channels. They are applicable to any scenario due to their simplicity. In [69], a CCC design using random frequency hopping is proposed as

AMRCC for symmetric channels in which preference is given to channels with less interference towards the primary users. However, it requires an initial sensing period to sense all channels and to assign ranks to the channels and each node follows a common hopping sequence. Such assumption is unrealistic as some channels might not be available to other nodes and initial sensing time can increase the network setup delay. In [40], a Random channel hopping algorithm is also used to compare against the Modular Clock Algorithm [40]. Two randomized neighbour discovery algorithms are presented in [70] for heterogeneous wireless networks, based on synchronous and asynchronous timeslots. In both algorithms, nodes select a channel at random from the available channels set and decides their roles as a sender or receiver based on the probability. In the first algorithm, an upper bound on the node degree in the network is assumed as known. In the second algorithm, there is no such assumption, and therefore each node assumes a maximum estimate of node degree in each phase (which consists of a number of timeslots). Once the estimated number of nodes are found, node increases the estimated number by one and keep running the discovery algorithm. The drawback is that in such assumption, nodes will not know when to stop the discovery algorithm and can go for an infinite time without being sure about the total number of nodes discovered. Even if nodes stop their discovery process at some random time, the total number of nodes discovered will remain uncertain. The primary user activity is not considered, due to which a guarantee cannot be achieved.

From the existing literature, the Number theory (MCA) and Jump-Stay based strategies are the only one which does not require any initial information to generate the channel hopping sequences at different nodes, does not assume a role based node function and have the low complexity. Therefore, they are selected for comparison in this work. However, they still assume the known number of nodes in advance.

3.6 Discussion on issues of existing CRN rendezvous strategies

The existing rendezvous strategies for CRNs are reviewed in the previous section and Table 3.1. Almost all of them work for multiple users and multiple channels. The majority of the rendezvous strategies are based on number theory (modular arithmetic and JS based), due to the low complexity of the associated algorithms. Other types like Quorum system, Galois-field, Matrix or Combinatorial based strategies require a complex process to generate channel hopping sequences in advance and require some initial

information (like ID information) to generate other node's CH sequences [56, 58], due to which they remain not completely blind. Most of the work considers asymmetric channels and available channel sets. However, some strategies use a global channel set to achieve rendezvous [37, 43, 56, 59, 66, 68], which is an unrealistic assumption. In real environments, due to the geographical distance between nodes and localised primary radio activity at different locations, the channels at different nodes might not be same. Almost all of the papers assume a slotted system and because it is difficult to achieve global synchronization among all nodes, asynchronous timeslots are mostly considered. Most of the work still assumes a role-based rendezvous operation in which roles of a node as a sender or receiver are pre-assigned. In reality, when nodes are unaware about the existence of other nodes in a network, and two nodes with similar roles (as a sender or receiver) are in range, they can never achieve rendezvous with each other [41, 42, 44, 51, 56]. The rendezvous approaches in which the nodes work as either a sender or receiver require different CH sequence generation methods while the approaches in which each node can work as a sender and receiver requires just one method to generate channel hopping sequences. In [55, 70], roles are assigned at random and based on some probability to work as a sender or receiver. In these approaches, although the guarantee is theoretically proved, the time to rendezvous is long, which is due to the nodes which choose to stay on a channel will never attempt a rendezvous for some specified bounded time. Almost all the strategies shown in Table 3.1 guarantees the rendezvous within some bounded time. However, their guarantees are conditional, as in [40, 48, 49], the guarantee is dependent on choosing different *rates* (i.e., the hopping factor). In sequence generation based rendezvous strategies, the guarantee is dependent on picking same or different channel hopping sequences, as shown in [46]. In [42], it is shown that rendezvous is guaranteed only when nodes pick different roles (as a sender or a receiver). Further, none of the work presented in previous section provides a rendezvous guarantee in presence of a PR activity, which if appears can invalidate the rendezvous guarantee.

In the recent literature on rendezvous protocols primary radio activity is considered for the performance analysis. However, none of the work provides a guarantee in the presence of primary user activity, due to the unpredictable and dynamic nature of licensed channels. It is shown in these works that time to rendezvous increases with increase in the primary user activity traffic. In a real environment, each channel possesses different physical characteristics, traffic intensity and traffic patterns on different channels might be different, which can affect the rendezvous performance. However, even in the works in which primary user activity is considered the different traffic patterns are not considered for the performance evaluation. The adaptiveness towards unknown

and increasing primary user activity should be the main goal for rendezvous protocol design. But, the existing rendezvous strategies are not adaptive. In [69] channels with low PR activity are given preference and are ranked. However, it requires an initial sensing of all channel for a long time to assign ranks to particular channels, which can increase the accuracy but can also increase the network setup delay. According to IEEE 802.22 [6], a radio which detects primary user activity on a channel must leave that channel immediately and also must not use it for some time. However, none of the work until now considers the real cognitive radio network restrictions and its impact on the rendezvous protocols performance. The cognitive radios are only allowed to operate on those channels which are not occupied by a primary radio. None of the work considers the harmful interference a CR can create towards a primary radio system.

An important aspect of blind rendezvous strategies in disasters is the unknown information of nodes and topology. However, all known works considers that nodes are aware of the existence of all the other nodes in the network in advance. In unknown environments, these rendezvous strategies cannot work, as they are designed only for a known number of nodes with known topologies. Only a few of the works, like [48,68] considers the multihop design but with an already known number of nodes. These strategies work by exchanging the CH sequences and forcing other nodes to follow their CH sequences; and also assumes a global channel accessibility across the network. In [70] the unknown number of nodes are considered, however it assumes a maximum number of nodes in the network and gradually increases it to achieve rendezvous with all nodes. When the assumed nodes number is higher than the actual nodes number the algorithm will run infinitely and when assumed node number is less than the actual node number the algorithm stops prematurely. When the assumed number of nodes cannot be met due to different channels selection repeatedly, the algorithm terminates with uncertainty. In real environments, the nodes also cannot discover each other due to the unknown PR activity, which is also not considered in this work.

Ideally, the rendezvous algorithms are for achieving synchronization among different nodes so that later network services can be established. Further, these should also work in a self-organising manner to facilitate any new arrival or leaving of a node and should know when to stop and restart the rendezvous process. However, none of the protocols in the literature are self-organising in nature, which knows when to stop and when to finish the rendezvous process. Further, none of the multihop approaches address how to schedule communications after the rendezvous process to establish the network services (i.e., pairwise rendezvous is not enough).

3.7 Requirements and challenges of a fully blind rendezvous protocols for CR based DRN

The blind rendezvous algorithms suit the environments like disasters, in which spectrum environment and nodes remain unknown until explored. However, so far the work on rendezvous strategies in CRNs consider the number of nodes as known in advance and only considers the unknown channel information as a blind factor. In disasters, the unknown nodes, primary user activity, topology and existing survived networks are the additional blind factors which make the problem even more challenging and fully blind. Currently, the existing works are not fully blind. Therefore, the key requirements and challenges of a fully blind rendezvous protocols are identified for cognitive radio based disaster response network.

Rendezvous delay: The existing rendezvous strategies provide a conditional guarantee of rendezvous in bounded time. But these guarantees are only provided for limiting and unrealistic conditions. Few of them consider the uncertainties of unknown environments like unknown number of nodes, topologies, and primary user activity, and none address all of these factors. Achieving minimum or optimal rendezvous delay to minimize the network setup delay in presence of these unknown factors is required.

Unknown and asymmetric multiple channels: Due to the absence of spectrum databases, acquiring CCCs or the channels accessibility information in disaster environments is hard. Therefore, a cognitive radio should be able to sense its environment and available channels to operate. Due to channels spatial diversity, each node may perceive different available channels at different locations. When nodes are not aware of the channels at other nodes and use a global channel set to achieve rendezvous, the rendezvous can take longer to complete. Further, due to unknown primary user activity and longer rendezvous cycles or channel hopping sequences, the time to rendezvous can be high. These factors should be considered in designing a fully blind rendezvous protocols.

Unknown starting times and asynchronous timeslots: As nodes might be unaware of the other nodes in the network, it is difficult to know their starting times and to achieve the global synchronization among different nodes. Therefore, the fully blind rendezvous must be able to achieve rendezvous when the starting times of other nodes are unknown and their timeslots are not synchronised.

Unknown number of nodes, topologies, and termination of rendezvous process: The existing rendezvous strategies so far consider only the known number of nodes

both for single and multiple hop scenarios. Therefore, they can not be directly applicable to disaster scenarios, as the nodes might be unaware of the existence of other nodes in the network. It is also not realistic to assume that all nodes are always within one hop distance range of each other. When nodes are not in direct range of each other and hear about each other from another node, running the rendezvous process forever will not be able to establish a direct connection. Therefore, the fully blind rendezvous protocol must be able to work for multihop and unknown topologies together with an unknown number of nodes. However, for an unknown number of nodes they also require an efficient termination condition to stop at some point. Otherwise, these strategies can either stop prematurely without discovering all nodes or might take infinite time due to the uncertainty of the total number of the nodes in the network.

Role independent: Restricting some nodes to perform specific duties as a sender or a receiver can provide rendezvous guarantee but only when the roles between the two nodes are different from each other. In disasters, knowing such information might not be possible and rendezvous cannot be achieved between two nodes when they have similar roles and even when they are close to each other. Therefore, the fully blind rendezvous strategies must not fix such pre-assignment of roles.

Adaptiveness towards unknown primary user activity Cognitive radios are used mainly for dynamic spectrum access and are meant to operate opportunistically over the licensed or unlicensed bands. However, the availability of the licensed spectrum might change with time and space due to different and unknown arrival rates of primary users on different spectrum bands. The rendezvous protocol should consider the primary user activity on channels and should also avoid attempting rendezvous on those channels. However, not attempting rendezvous on PR detected channels can result in higher time to rendezvous values and operating on these channels may result in the harmful interference. Therefore, the fully blind rendezvous protocols should be carefully designed to respect the primary user activity; must not create the harmful interference; and should be adaptable with unknown and increasing primary user activities.

CR operating policies: A cognitive radio is only allowed to use the spectrum opportunistically when it follows some rules which are meant to stop interference with the primary radio communication and at the same time should also provide sufficient QoS. The existing blind rendezvous does not consider the policies suggested by the standard bodies. When a cognitive radio detects any primary user activity on a particular channel, it should vacate that channel and must not use it for some time. Before using any channel, it should also make sure that no primary user is currently active on

that particular channel. The existing blind rendezvous strategies, do not consider operating policies for the cognitive radio. These operating policies should also be carefully designed for the emergency scenarios. For example, if a channel is dedicated to an ambulance service then it should not be used. If any other channel is detected with primary user activity then it should also be restricted for some limited time to reduce the harmful interference towards the primary user activity. These policies can easily be implemented on a reconfigurable radio before starting their rendezvous operation. Harmful interference should not be created as there might be some survived networks which can be using their licensed spectrum to provide services.

Self-organization: At all times, the disaster response network should work on its own without much assistance. The nodes might run out of battery and therefore can disappear. New CR nodes might be launched and need to join the network. The existing rendezvous strategies are not designed to facilitate the unknown nodes leaving or joining the network. Therefore, the fully blind rendezvous strategy should know when to stop the rendezvous process and when to start it again. For example, if sufficient or all nodes are discovered then it should stop its rendezvous process. However, when a new node enters into the network, the rendezvous process should not only start again but also should update and disseminate the new node information all across the network.

Scheduling, synchronization, and information sharing: In multi channel and multihop environments, achieving and maintaining synchronization among nodes is challenging. Nodes can decide future rendezvous points to meet and exchange messages. Therefore, an efficient scheduling mechanism among nodes is also required to update the rendezvous information periodically to avoid running a complete rendezvous process again and which can also reduce the time to establish other network services. It is also important to share the network-wide neighbour information among all nodes to support other network services like routing, broadcasting, data transmission etc.

3.8 Cognitive Radio Operating Policies

Policies are the set of rules adopted to perform some actions or to restrict from doing some actions. In cognitive radio networks, these policies define conditions for the radios to operate on the available frequencies based on allowed time, transmit power, geographical locations etc. These policies can be established by standard bodies, regulators, system operators, manufacturers etc., and can be reconfigured also by system operators even before deployment in emergency scenarios. The standards and reports

related to requirements of a disaster response network regarding a CR and DSA are already discussed in Chapter 2. In this section, the focus is mainly on policies suggested by these standard and regulatory bodies like IEEE, FCC, Ofcom, DARPA etc. A detailed survey on cognitive radio standards is shown in [72]. Below are some of the standards for TVWS and Radar bands, which suggests the operating policies for a cognitive radio.

- IEEE 802.22, Part 22 (2011): This document describes the Physical and MAC layer specifications of Cognitive Wireless RAN with policies, procedures, and operation in TV bands.
- IEEE 802.22.2, Part 22.2 (2012): This document describes the Installation and Deployment of IEEE 802.22 Systems in TV bands.
- IEEE 802.22b (2015): This document describes the enhancements for advanced WRAN to support broadband emergency services, broadband services, remote medical services etc, and provides all essential functionalities of IEEE 802.22 standard.
- ITU-R M.1652 (2003) and M.1652-1 (2011): This document describes the Dynamic Frequency Selection (DFS) in wireless systems including Radio Local Area Network (RLAN) for protecting the services in the 5 GHz band (Radar bands) and related satellite services.

The recommendations and suggestions mentioned in these documents are mainly to allow a coexistence between secondary and primary users on licensed bands and to protect the primary users from the harmful interference. The key recommendations mentioned in these documents for opportunistic spectrum access are shown in Table 3.3.

3.8.1 Policy-based Radio

The behavior of the radio system should be managed by some modifiable policies to permit or prohibit spectrum access based on time, location, channel condition etc. [73]. These policies can be used for static or dynamic spectrum allocation to limit the usage of certain frequency bands for some allowed time or to restrict them from using for a long or short time. These policies can describe how a radio is allowed to operate on some channels and can be modified by changing the policy files. These modifications can be applied at the time of manufacturing a device, before deployment or even at runtime. The software-defined radio supports the reconfigurability at run time based on the input from the environment. Therefore, these policies should be dynamic to

Table 3.3: Standard recommendations for TV and radar bands

Recommendations	Description	TV bands	Radar bands
Channel Availability Check time (CAC)	The time for which a channel must be monitored for the presence of a primary user.	30 s	60 s
Channel Non-occupancy period (CNP)	The time for which a cognitive user must not use the channel on which a primary user is detected.	10 m	30 m
Channel Move Time	The time required by the system to clear the channel for any ongoing transmission.	2 s	10 s
Channel Closing Transmission Time	The total allowed transmission time during the channel move time.	100 ms	1 s

perform some actions on its own based on input from the environment or primary user detection. For example, secondary users can operate on available channels, as long as the primary user is not detected on the channel. However, when a primary user activity is detected, then the secondary users should not only vacate those channels but also avoid them for some time. Similarly, when some channels are continuously being detected as occupied then they should also be avoided for a long time. Therefore, to transmit on a particular band, it is required that the band must not be occupied by a primary user, it must be within the capabilities of a radio and there is a policy which decides its counter actions based on the application and scenario. These counter actions can be determined in a reactive or proactive manner. For policies based on proactive actions, the channel status, and primary user status prediction [74] can also be made part of the policies to decide the next action or channel selection.

The standard bodies recognise that policy-based radios can efficiently use the spectrum bands [73]. The policy-based radios can even be more efficient, when sensing, reconfigurability and decision making functionalities are combined, like in software-defined or cognitive radios. Some of the advantages of policy-based radios are listed below,

- They can provide the flexibility in usage of spectrum for a short time or long time or with specific schedules.
- They can enhance the decision capability of a cognitive radio.
- They can be set in a way to protect the primary users from the harmful interference.
- They can specify the allowed power limits of frequency bands.

- They can be used to provide location-based frequency allocation to protect the primary users.
- They can decide to perform next action to achieve seamless communication by deciding immediately the next channel usage or by using a backup channel.
- They can evolve over time and can provide artificial intelligence.
- Depending on the application scenarios they can be modified easily.

In the existing literature, cognitive radio operating policies are not utilised until now for the performance evaluation of a CR system. The importance of policy-based radios and operating in white spaces are described in [73] and [75]. The policies should be defined based on the application scenarios to efficiently utilise the spectrum resources and to keep the harmful interference ratio within the acceptable limits. The acceptable limits can be negotiated in advance before deploying a system with service providers or must be kept at a negligibly low level to not to degrade the primary systems performance (ITU-R M.1652-1, 2011).

In disaster situations, these policies should be designed carefully so that timely response can be provided with minimum network setup delay. These policies should also be designed in a way to help increase the self-organization, interoperability, and adaptivity.

3.9 Primary Radio Activity Model

The performance of cognitive radio network is highly dependent on the primary user activity. The cognitive radio has the flexibility to operate on different spectrum bands ranging from kHz to GHz. It is important to monitor the primary user activity traffic for possible cognitive radio communication into the white spaces. A lot of work has been done on measurements of primary users including cellular, TV, Radar and Satellite bands for general occupancy, interference identification, coverage estimation and primary user arrival rates [76, 77]. The measurement studies are conducted to extract different statistical properties of spectrum occupancy. Based on these measurement studies different primary user activity models are identified [76, 78, 79] for dynamic spectrum access (DSA) and CR systems. The main function of these models is to simplify the real spectrum environment to provide a tractable and realistic representation of spectrum so that they can be used in analytical studies and computer simulations for the performance evaluation of DSA and CR systems. Therefore, PR activity models are

widely used to represent a spectrum usage pattern and measurements for performance evaluation of a CRN [80].

Different primary user activity models are discussed in [76, 78, 79] and mainly classified into Markov process, Queuing theory, time series and ON/OFF models. Among different PR activity models, Markov chain based PR activity models are widely used in the literature [81–85].

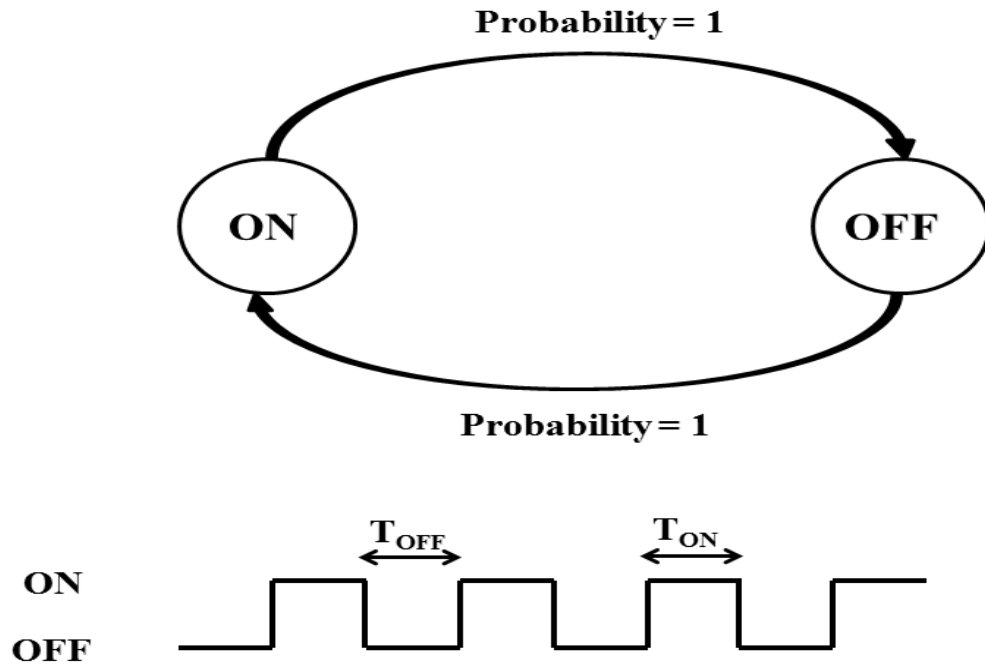

Figure 3.3: Alternating Markov renewal process for PR activity.

For DSA/CR systems, the occupancy pattern of a PR can be modeled as a two-state Markov chain (as shown in Figure 3.3), where the two states are *ON* and *OFF*. *ON* means the channel is busy and should not be used while *OFF* shows that the channel is free or idle and can be used by a CR. The continuous time alternating *ON/OFF* Markov Renewal Process is used in [80, 83–85] to model PR activity. This model is also been used for the performance evaluation of CRN [80, 86–91]. It is also used for public safety bands [92, 93], voice [94] and IEEE 802.11b [95]. This model makes following assumptions when the current state of a channel is i .

- the time will be exponentially distributed until the next channel state transition and it will be independent of the past history of the previous channel-state.
- the next state will be j with probability P_{ij} and it will also be independent of the previous state and process until next transition.

In this model, the duration of *ON/OFF* states of a channel i is denoted as T_{ON}^i

and T_{OFF}^i . The renewal period $Z_i(t)$ will occur when one *ON/OFF* period is complete [83, 84], where,

$$Z_i(t) = T_{ON}^i + T_{OFF}^i \quad (3.1)$$

where the channels *ON/OFF* periods are both exponentially distributed [83–85] with p.d.f.,

$$f_X(t) = \lambda_X \times e^{-\lambda_X t} \quad \text{for ON state, and} \quad (3.2)$$

$$f_Y(t) = \lambda_Y \times e^{-\lambda_Y t} \quad \text{for OFF state} \quad (3.3)$$

where X represents the random variable for busy (or *ON*) state and Y represents the random variable for idle (or *OFF*) state. The duration of time in which channel i is in *ON* state i.e. U^i is given as [84],

$$U^i = \frac{E[T_{ON}^i]}{E[T_{ON}^i] + E[T_{OFF}^i]} = \frac{\lambda_Y}{\lambda_X + \lambda_Y} \quad (3.4)$$

where $E[T_{ON}] = 1/\lambda_{ON}$ and $E[T_{OFF}] = 1/\lambda_{OFF}$ are the means of exponential distribution and λ_X and λ_Y are the exponential distribution rate parameters. The probability of channel i being in *ON* or *OFF* state at time t can be calculated as below, where $P_{ON}(t) + P_{OFF}(t) = 1$.

$$P_{ON}(t) = \frac{\lambda_Y}{\lambda_X + \lambda_Y} - \frac{\lambda_Y}{\lambda_X + \lambda_Y} e^{-(\lambda_X + \lambda_Y)t} \quad (3.5)$$

$$P_{OFF}(t) = \frac{\lambda_X}{\lambda_X + \lambda_Y} + \frac{\lambda_Y}{\lambda_X + \lambda_Y} e^{-(\lambda_X + \lambda_Y)t} \quad (3.6)$$

Different PR activity patterns can be generated using this model and tune the exponential distribution rate parameters (i.e., λ_X and λ_Y) for *ON* and *OFF* periods.

3.10 Cognitive Radio Simulation

For performance evaluation of a cognitive radio network, different simulators are used in the literature, as shown in Table 3.1. Most of the existing works use a custom

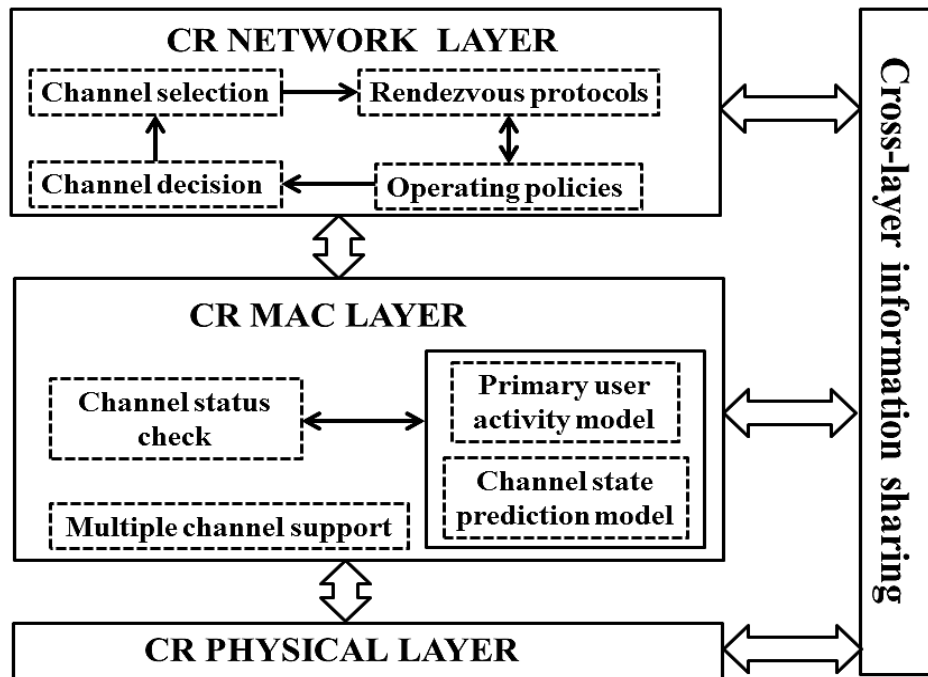

Figure 3.4: Main blocks of Cognitive Radio Network Simulator.

based simulator for the performance evaluation. A Cognitive Radio Cognitive Network (CRCN) patch [96] of NS-2 to implement a CRN is also used in the literature for the performance evaluation of a CRN [80, 87, 88]. Mainly it has three function layers i.e., Network, MAC and Physical layer, as shown in Figure 3.4. A simple MAC protocol (maccon.cc) is modified, which is a collision and contention-based MAC protocol. It is also extended with PR activity model, which is responsible for the channel based PR activities i.e., channels *ON* and *OFF* periods over the simulation time. The rendezvous protocols, operating policies, and channel selection decision are implemented at Network Layer. The PR activity model and channel state prediction model are implemented at MAC layer. Physical layer has the Transmission power, SNR, propagation model etc. Each module implemented are shared using a common information sharing layer.

The Network layer contains the rendezvous protocols, cognitive radio operating policies block for channel selection and channel decision block. After a channel selection, the channel decision block passes the channel to lower layers for channel sensing output, based on which it decides to continue on a particular channel or contact the rendezvous algorithm or particular policy for next channel selection. The neighbour information is encapsulated in the packet header and then passed on to the lower layers. The MAC layer has the channel status check or sensing mechanism which contacts the

PR activity block for acquiring the channel sample at a particular simulation time for channel occupancy by a PR. On receiving a channel occupancy status as ON , a channel hand-off signal is sent back to Network layer's decision block, which then initiates a new channel selection. No transmission occurs when a channel hand-off mechanism is initiated. The channel status prediction module works in parallel to calculate the channel's weight and prediction.

3.11 Summary of the chapter

In this chapter, the existing published literature is reviewed to identify the requirements and challenges for a multihop blind rendezvous protocol for an unknown environment, with primary radio activity model and CR operating policies. The existing literature on blind rendezvous protocols cannot guarantee a rendezvous in the presence of unknown primary user activity and their time to rendezvous is long. Mostly, literature assumes a role-based CR operation which can also invalidate a rendezvous guarantee. They cannot be even directly applicable to a disaster response network because none of the paper is considering an unknown environment. The blind factor which is considered mostly only relates to the unknown channels information. However, in disasters, the number of nodes and topology information might also be unknown. Some of the existing literature considers the PR activity, however their time to rendezvous increases with the increase in the PR activity and therefore are not adaptive. None of the work considers the suggestions of the standard bodies, which are meant to protect a PR against the harmful interference. The policy-based radios are encouraged by the standard bodies, but the impact of different operating policies on blind rendezvous protocols is still unknown. The disaster environment requires a fully blind multihop rendezvous solution. Therefore, it is required that it must be able to work with an unknown number of nodes, channels, and topologies. It must also be adaptive to the unknown primary user traffic and must be able to self-organize i.e., it should work autonomously by facilitating any node entering or leaving the network, and should know when to stop its rendezvous process and when to restart it again. Further, it must also follow the specifications to minimize the harmful interference towards the PR system. The main aim of establishing a rendezvous among the nodes is to gather the timely information to establish other network services. Therefore, a timely and efficient fully blind multihop rendezvous strategy is required to reduce the network setup delay in an unknown environment.

Chapter 4

Experimental evaluation of a software defined radio-based prototype for a disaster response cellular network

4.1 Introduction

Large-scale disasters can cause significant infrastructural damage. In particular, existing communication networks may get destroyed, hampering the ability of emergency responders to communicate with each other, and of victims to make contact with rescue services and relatives. Therefore, it is vital to quickly restore voice and data communication services. Currently, portable wireless systems are used as a temporary solution. However, these solutions have a lengthy setup, limited coverage, and typically require the use of expensive satellite backhaul. A rapidly deployable communication network is required, which must be sufficiently reliable and robust to support mission critical requirements, including quality of service (QoS), mobile user support, and interoperability with existing network infrastructure. It should provide wide-area coverage, and support a variety of different access technologies (WiFi, 2G, 3G, 4G etc.), and it should survive for enough time to allow more stable deployments to be put into place. In this chapter a prototype system for rapid deployment in post-disaster scenarios is investigated.

Disaster response networks based on software defined radio (SDR) [25] and cognitive radio (CR) [4] have been proposed [5]. These technologies are designed to sense and observe the available spectrum, and to reconfigure their parameters at runtime. This flexibility would, in theory, allow the network to recognise and respond to whatever ac-

cess services were being requested, and the spectrum agility would allow communication backhaul to be configured autonomously in real time to adapt to the unknown and dynamic radio environment, thus avoiding the need for time-consuming site surveys, multiple access networks, and manual configuration. Given the demands of disaster response, the backhaul network may have to be multi-hop, involving heterogeneous technologies, because of possible unknown distance between two surviving base stations which need to be connected. Although CR and SDR are promising technologies in a maturing research field, there have been few published practical deployments, and thus their ability to operate in harsh environments while providing support for legacy user equipment and end-user access services has not yet been properly established.

In this chapter, a prototype is presented for a rapidly deployable disaster response network using software defined radio for voice communication. Our first aim is to establish whether or not the technology can support end-user services, and for this prototype, GSM is used as the access technology, and IEEE 802.11 unlicensed bands are used for backhaul. An OpenBTS software is used as an implementation of the GSM protocol stack running on consumer laptops, connected to a Universal Software Radio Peripheral (USRP) from Ettus Research. Two OpenBTS base stations are connected using WiFi connections between the laptops, with one of the laptops running the open source Asterisk PBX to manage the call routing and monitoring for each mobile phone which connects to our network. The Asterisk server is able to provide connectivity to the public switched telephone network or to the Internet. The prototype is evaluated experimentally, under different network conditions, and varying the number of real and emulated voice calls. It is demonstrated that the technology can support voice communication, maintaining over 40 calls simultaneously with acceptable jitter, packet loss and mean opinion scores. However, it is shown that this performance is only obtained when the external radio environment is quiet. In environments where communication links are highly occupied (i.e., noisy environments), call quality degrades significantly, allowing fewer than 5 calls simultaneously before jitter and packet loss become unacceptably high. Through analysis of the packet traces, it is shown that the packet losses are caused by radio interference on the backhaul link. The main contribution of this research lies in demonstrating the limits of using unlicensed bands to support voice communication (GSM-VoIP). The results indicate that true spectrum agility and cognitive radio techniques will be required to support the necessary services.

4.1.1 Main contributions

The main objectives and contributions in this chapter are as follows,

- To design a robust, flexible, light-weight and low cost solution for a disaster response network.
- To establish a feasibility of the SDR to restore voice communication services in a disaster with,
 - a frontend to support communication services (like GSM)
 - a backend to connect multiple radios with sufficient quality of service and wider accessibility and coverage
- An experimental evaluation of system capacity under varying traffic loads

4.2 Disaster and SDR based Solutions

The main requirements for disaster response networks (DRNs) cover measures including quality of service, robustness, coverage, deployment speed, interoperability and cost effectiveness, as specified by, for example, SAFECOM [7]. Various rapid response network services are already available, provided by telecommunications vendors and government organisations [5, 9, 97–99]. These services are a vital and successful part of the response effort, but their scope is limited, they covers only specific areas, take significant time to deploy, and almost all require the use of expensive satellite backhaul, even for local calls. Few current service providers offer interoperability, self-organization, or dynamic spectrum utilization. As discussed in [5, 15], cognitive radio systems have been proposed as solution techniques for immediate flexible deployment, to provide a working network until more stable solutions can be deployed. Such systems should self-organize, to reduce the need for manual configuration. Further, they should be capable of operating in a wide range of frequencies to avoid the need for having prior spectrum information, and should be able to adapt to unknown and changing environments. Figure 4.1, shows an example of a disaster scenario in which mobile flexible base stations could be deployed to provide a multi-hop backhaul to connect users requesting different services to the remaining infrastructure. As yet, it has not been demonstrated that cognitive radio or software defined radio with an ad hoc wireless backhaul can support the required user services.

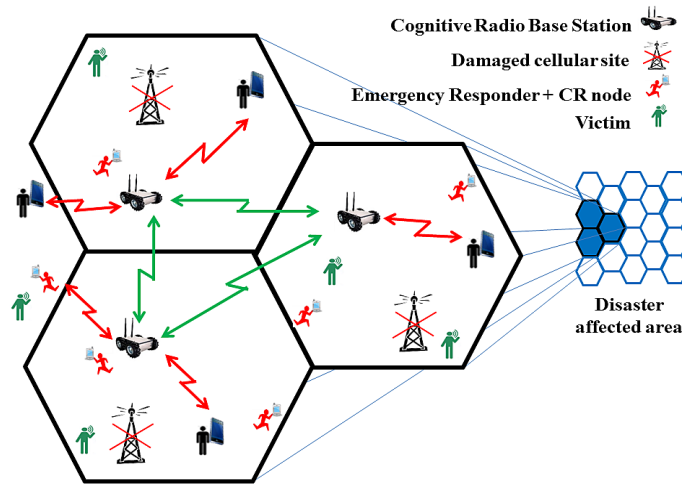

Figure 4.1: An example for partially destroyed network extension.

Table 4.1: Existing Backhaul Technologies [100]

Technology	Capacity	Coverage	Cost
Copper (T1/E1)	Low [T1=1.54 Mbit/s]	No requirements	High
Optical Fibre	High [upto 155.52 Mbit/s]	No requirements	High
Ethernet	High [upto 1000 Mbit/s]	No requirements	Low
Microwave	High [2 - 170 Mbit/s]	LOS requirement	High maintenance and spectrum cost
Satellite	Medium[384 Kbits/s to 4.09 Mbit/s]	Flexible	High
Wi-Fi	High [11 Mbit/s (802.11b)] [54 Mbit/s (802.11 g)] [600 Mbit/s (802.11 n)]	LOS required (upto 38 km)	Low
WiMAX	High [75 Mbit/s] [350 Mbit/s]	LOS (50 km) and non-LOS (25 km)	High maintenance and spectrum cost

4.2.1 Cellular Backhaul connectivity

Backhaul communications are required mainly to extend the coverage and service area, for which both wired and wireless links are being used currently. Optical fibre, microwave and satellite links are mainly used for the cellular backhaul connectivity [100]. In disasters, however, wireless solutions are preferred over wired solutions due to difficult physical access. Among wireless technologies, WiFi and WiMAX are gaining interest due to their low cost and rapid deployment [100]. Table 4.1, shows the capacity and cost comparison of existing backhaul technologies.

The Microwave transmissions are carried out on different frequency bands, like licensed 6 - 38 GHz and unlicensed 2.4 and 5.8 GHz. Using the unlicensed bands can reduce the capital expenditure (CAPEX) but raises the interference issues which effects the bandwidth capacity and coverage. They also require proper line of sight (LOS) between cell sites and therefore in remote areas it can be installed easily and can cover longer distance. Implementing Microwave links results in higher CAPEX because of

equipment and spectrum fees, however they are potentially to receive less operational expenditures (OPEX) over time. They can also be implemented in multihop configuration. While using the satellite links the advantages are short installation time and flexible coverage but the disadvantages are high cost and long propagation delays. The acceptable propagation delay for end-to-end voice services is 250 ms whereas the propagation delay offered by satellite links is 270 ms [100, 101]. Additionally, the cost ranges from \$3000 to \$12000 p.m [100]. Long distance WiFi can be an alternative low cost solution for backhaul connectivity, in place of microwave. However, due to outdoor point-to-point links for a backhaul it poses some design issues relevant to the achieved throughput, distance coverage, packet overhead, and time synchronization [100]. These issues include a multi-path problems which can be avoided as long as the delay spread is below the symbol duration and at the MAC layer many parameters are not suitable for the outdoor environments like the acknowledgement (ACK) timeout, contention window and round-trip time. The default ACK timeout for 802.11 is $20 \mu s$ which is too short for long distance link, however the propagation delay for 15 km is $50 \mu s$. Further the concatenation and compression techniques are required for the VoIP packets delivery over the long distance links [100]. It is also mentioned in [100], that the Hybrid coordination function Distributed Channel Access and Enhanced Distributed Channel Access must also be carefully designed to be used to support the residential broadband connectivity in addition to the cellular backhaul traffic. WiMAX provides higher throughput and wider coverage compared to WiFi. It can operate in both licensed (700 MHz, 2.3 GHz, 2.5 GHz and 3.5 GHz) and unlicensed (2.4 GHz and 5.8 GHz) frequency bands. WiMAX is less costly as compared to microwave in terms of spectrum fees. It can operate in non-LOS scenarios. It can connect in point to point (PTP) and point to multi point (PMP) and mesh technologies. Microwave technologies can guarantee QoS and time synchronization with 2-170 Mbit/s. However, it requires clear LOS with high CAPEX, in terms of high maintenance and spectrum fees. Satellite has a flexible coverage range but it is more expensive and suffers propagation delays. WiFi and WiMAX are emerging backhaul technologies because of high throughput and long distance coverage. WiFi suffers from low packet efficiency, lack of QoS guarantee and synchronization mechanisms [100, 101]. WiMAX is a good solution, but its cost is high due to licensed spectrum fee. For these reasons, the WiFi technology is investigated for backhaul connectivity as an initial approach, and leave TV White Spaces through dynamic spectrum access techniques to utilize the spectrum efficiently in disaster situation for future use.

4.2.2 Differences with existing solutions

Our prototype system consists of a software defined radio GSM access, with an 802.11 wireless backhaul. Some similar systems have been considered in the literature for other purposes. The VillageLink project [102] [103] has developed a platform to provide GSM services in remote rural locations where there is insufficient cellular coverage. A single Base Transceiver Station (BTS) deployment is presented in [102, 104] and [105], but without backhaul connectivity and thus with limited coverage. The closest system to ours, and part of the inspiration for our work, is described in [106] and [107], in which a local cellular network with multiple BTSs and WiFi backhaul is proposed to provide basic voice and text services, also using OpenBTS, USRP and Asterisk. Those systems were successfully field-tested. However, there are significant differences in the design and operating conditions. For example, a more expensive multiradio router is used in [107], which transmits/receive using different channels. The rural networks are intended for long term stable deployments, and benefit from site surveys and careful network planning. More importantly, because of the remote deployment, minimal interference is expected on the backhaul links, and so the effect was not studied. VoIP performance analysis for 802.11 is discussed in [108, 109] and [110], using simulations and implementation, but for different service environments, voice codecs and without stretching the backhaul link capacity. For example, in [108] the codec used is G.711, with a data rate of 64 kbps, supporting up to 13 calls.

4.3 Prototype multi-BTS GSM-802.11 network

The goal of the research described in this chapter is to establish whether or not a software defined radio front end and wireless backhaul could provide the required services of sufficient quality. For that purpose, the focus is on enabling a single access technology (GSM), and a simple wireless backhaul using 802.11 on consumer-level peripherals. The GSM is chosen because of its widespread availability [3, 99]. The software based GSM network and low cost mobile phones makes it an affordable solution for voice and data services in disaster situations [5]. OpenBTS [111] is so far the only complete open source software based solution for GSM services available. To provide the front end, the OpenBTS implementation of the GSM protocol stack is used, with the radio front end implemented on Ettus Research Universal Software Radio Peripheral (USRP). The backhaul links are implemented as Ad Hoc mode WiFi on the laptops.



Figure 4.2: Universal Software Radio Peripheral.

4.3.1 Prototype building blocks

The main building blocks of a multi-BTS are explained in the following sub sections.

4.3.1.1 Universal Software Radio Peripheral

USRP is a hardware platform for SDRs [112]. It provides the radio communication system by implementing the filters, mixers etc., in a software on an embedded-system to transmit and receive data. Its motherboard provides the subsystems like field programmable gate array (FPGA), an analog-to-digital converter (ADC), a digital-to-analog converter (DAC), clock generation, host processors and power regulations, which are basic components required for baseband processing of signals. It includes a daughter-board for front-end analog conversions like up/down conversion, filtering and signal conditioning. It permits the USRP to serve applications that operates at 6 GHz including MIMO systems. The applications for which it is mainly used are public safety, mobile phones, spectrum monitoring, radio networking, cognitive radio, satellite navigation and discovering white spaces.

4.3.1.2 OpenBTS

OpenBTS is a software implementation of GSM protocol stack and replaces core GSM components such as Base Switching Centre, Mobile Switching Centre, Home Location Register and Visitor Location Registers on a software level. It is a software based GSM access point. It provides network functions like GSM registrations, location updating, handover and mobility management. OpenBTS provides "GSM Um" interface to any GSM cell phone within range. It receives GSM signals, demodulates them and converts them to VoIP packets. It can transmit and receive using SDR in the GSM band as a local GSM base station. It allows GSM compatible mobile phones to be used as

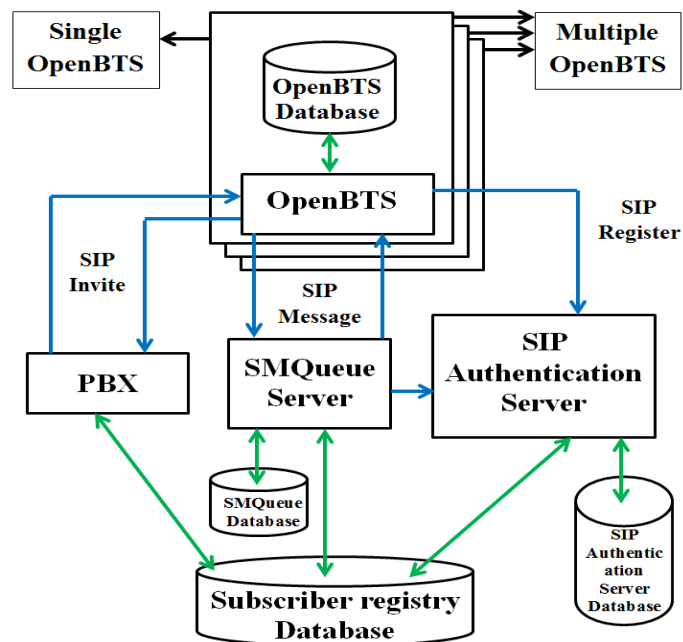

Figure 4.3: System diagram of single/multiple OpenBTS systems.

SIP endpoints in VoIP networks. It is developed by Range Networks, and the current version is 4.0 [113]

In Figure 4.3, a general system diagram of single and multiple OpenBTS systems is given, each of its components is described below. For single OpenBTS, SMQueue (text messaging server) and SIP authentication server can be configured on the same machine. However, for the multiple BTS, a separate copy of OpenBTS can be configured on different machines.

PBX: A call can be established when signalling between the two mobile phones is completed. The signalling is carried out using Private Branch Exchange (PBX). An open source Asterisk PBX is implemented, which considers mobile phones as SIP clients through OpenBTS and performs signalling using Session Initiation Protocol (SIP). It works as a server client model and also maintains a database for all the mobile phones associated with it. The Asterisk server manages the call routing and monitoring for each SIP user across the network, and can provide connectivity to the public switched telephone network or Internet. It can be configured on a separate machine or on the same machine as the BTS.

SIP authentication server: It is another major component of OpenBTS and provides SIP authentication services for registrations.

SMQueue server: SMQueue server provides the messaging services to the mobile phones.

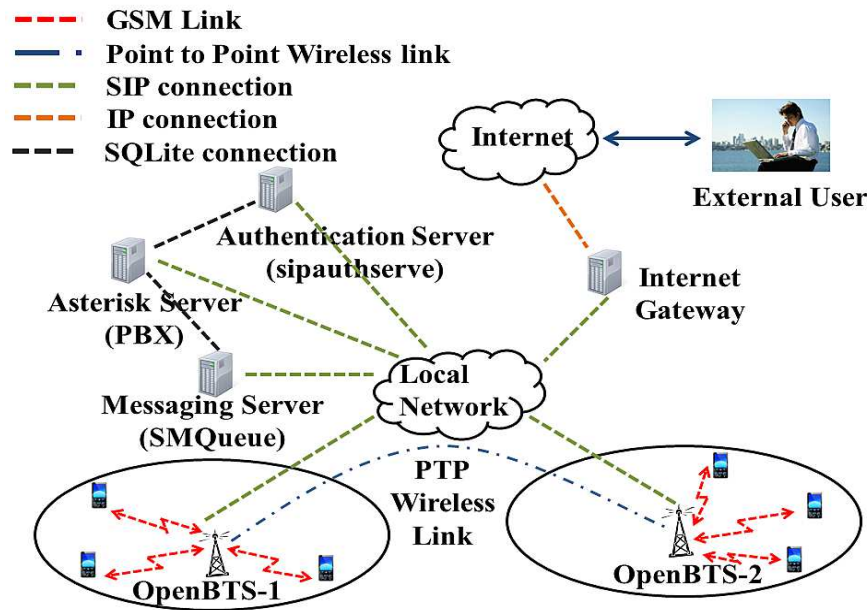

Figure 4.4: A general architecture of multiBTS prototype.

4.3.1.3 General architecture and external connectivity

In Figure 4.4, a general architecture of multiple BTS systems connected over a wireless link is illustrated. The external connectivity is handled by a PBX system. A PBX system is capable of allowing traffic to and from an external site. In our design, VoIP connectivity from an external site using a static IP on a separate machine is also established and tested.

4.4 Experimental Design

To test the system, as shown in Figure 4.5, two BTSs are connected over the backhaul using the WiFi link. The two BTSs use separate USRPs. The setup parameters are listed in Table 4.2. The systems is tested in an open lab environment, and we have no control of the external radio environment. In the lab, there are between 15 to 18 WiFi access points within range. The building opening hours are 7:30 a.m to 10:00 p.m, and most users are active from 9:00 a.m to 12:30 p.m and 1:00 p.m to 7:00 p.m. For the experiments, the two USRPs are placed 8 meters apart, with the GSM antennas 4 meters away from their BTS. Mobile phones are at a distance of between 5 and 25 meters from the antennas. The transmission range is set as approximately 50 meters, by reducing the power level of BTSs to reduce the interference. BTS-1 is configured with an Asterisk server on the same laptop, and BTS-2 on a different machine.

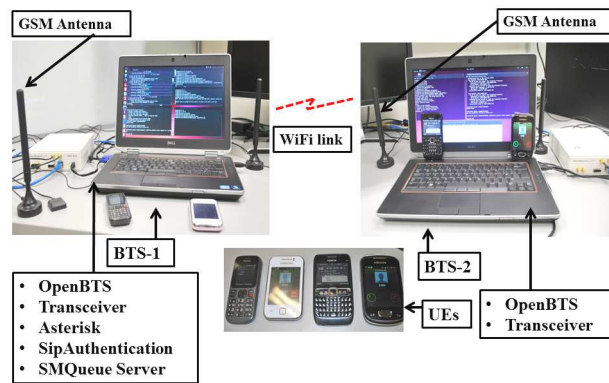

Figure 4.5: Prototype of a disaster response network.

Table 4.2: System parameters of DRN prototype

System Parameters	Description
PC	Dell Latitude E6420 (i5, 4GB RAM)
Wireless cards	Intel 1510
Wireless Standard	IEEE 802.11g (54 Mbps)
Voice Codec	GSM 6.10 (13.2 Kbps)
Type of traffic	BTS: SIP, RTP, UDP
Frequency	1800 MHz (GSM) (Test license from COMREG Ireland) 2412 MHz (WiFi channel 1)
Phones	Samsung S5360 (2), Nokia 101, E63
USRP	N210
OpenBTS	version 4.0

The SIP authentication server and SMQueue server are also installed on BTS-1. The experimental scenarios, backhaul link, background traffic and other preliminaries are discussed below.

4.4.1 Scenarios

Two scenarios are examined to test voice quality and backhaul link capacity. The call flows and measurement points are shown in Figures 4.6 and 4.7.

4.4.1.1 InterBTS Scenario

The two mobile phones or user equipments (UEs) in a call are subscribed to different BTSs. Both are controlled by PBX-1, which is at BTS-1. In this scenario, the calls are transmitted through the wireless link only once as an RTP stream.

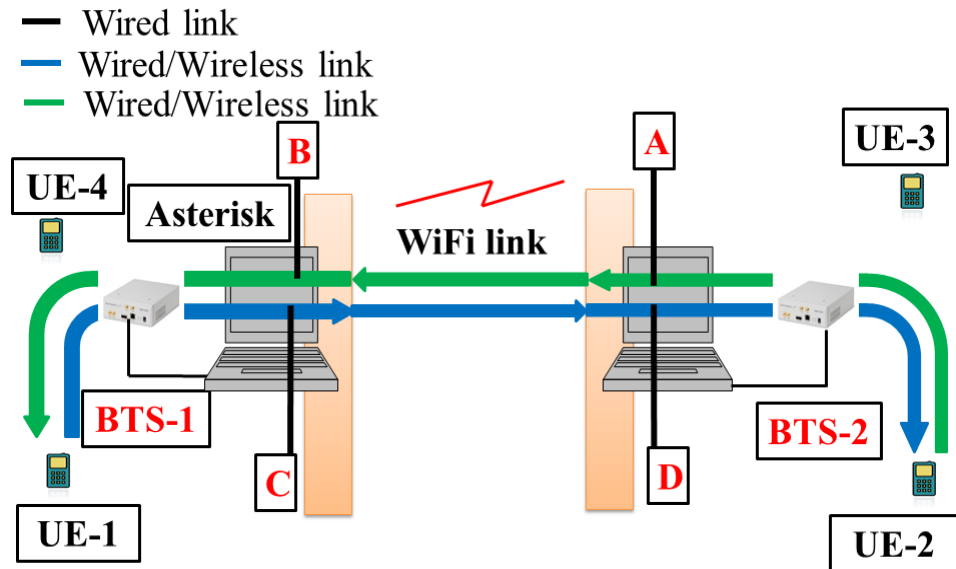

Figure 4.6: Call flow and measurement points in InterBTS Scenario

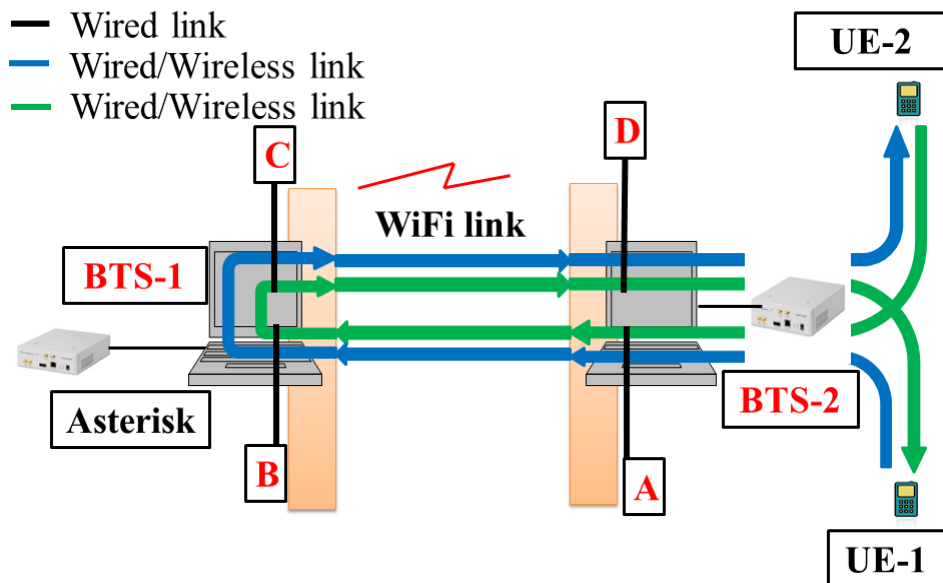

Figure 4.7: Call flow and measurement points in IntraBTS Scenario

4.4.1.2 IntraBTS Scenario

Both UEs are subscribed to BTS-2, noting that the Asterisk server is on the machine for BTS-1. In this scenario, the calls are transmitted over the wireless link twice, as the Asterisk and databases for OpenBTS are on BTS-1 and other UEs are on BTS-2. Due to the design of multi BTS support in OpenBTS, the call was first going to main BTS (at BTS-1) and even after call establishment of call. Therefore, the RTP streams has to traverse twice over the same wireless link.

4.4.2 Backhaul Link

For the experiments, channel 1 of 802.11g is used which is a non-overlapped channel preferred by routers mostly as a default channel. As we want to analyze the backhaul communication support in presence of external interference, channel 1 is utilized.

4.4.3 Background Traffic and Environment

As the experiments are conducted in an open lab, the external activity on the other networks cannot be controlled. Such traffic may cause interference on our backhaul link, and we want to compare the performance of the prototype under different external conditions. The tests were conducted at different times over a period of more than a week, focusing on two use cases: (i) (*quiet*) during the early mornings and late evenings, when external user activity was low, and (ii) (*noisy*) during the standard working hours, when external user activity was high. A separate laptop is used which is configured in monitor mode and placed in between both BTSs, to indicate the volume of background traffic. Figure 4.10d and 4.11d shows the background traffic monitored in the quiet environment for both scenarios. Similarly, 4.12d and 4.13d shows the background traffic monitored in the noisy environment for both scenarios.

4.4.4 Measurement points

The incoming and outgoing voice traffic were captured at both BTSs using Wireshark and averaged each set of test runs. To understand where, if anywhere, the communication links are degrading, the traffic is monitored at four points. These measurement points are selected to analyse the backhaul link as an end-to-end points. The GSM link from the USRPs to mobile phones is not used for the analyses because the GSM

data was in Raw format and could not be decoded to analyse the packet statistics. Another reason for choosing these measurement points is that the emulated calls were also generated from within the system used for the BTS system. In Figure 4.6 and 4.7, InterBTS and IntraBTS call flow and measurement points are shown and described below.

- A describes the outgoing traffic from BTS-2 for BTS-1.
- B describes the incoming traffic at BTS-1 from BTS-2.
- C describes the outgoing traffic from BTS-1 for BTS-2.
- D describes the incoming traffic at BTS-2 from BTS-1.

4.4.5 Equivalent Calls

To increase the number of calls in the system, the real calls are emulated, due to lack of sufficient UEs and SIM cards. The voice call (GSM FR 6.10) codec has a data rate of 13.2 kbps [114]. For real calls, real mobile phones are used for voice call establishment. For emulated calls, the UDP flows are generated and transferred at the same data rate using iperf from both BTS-1 and BTS-2. For each additional call, the number of UDP flows are increased. To validate the emulation, Figures 4.8 and 4.9 shows the jitter and packet loss values for 1 real and 1 equivalent call compared to 2 real calls, for both scenarios. Both show almost identical values, which gives confidence that the results obtained from many emulated calls will correspond to results that would have been obtained from a similar number of real calls. Note here that IntraBTS has twice the flows as InterBTS, because caller and receiver are both on BTS-2. Each RTP frame is of length 87 bytes, which includes 12/8/20 bytes for RTP/UDP/IP header size. The voice packets are sent at regular intervals of 20 ms.

4.4.6 Performance Metrics

The protocols used are session initiation protocol (SIP) [115], real-time transport protocol (RTP) [116] and RTP control protocol (RTCP) which consists of two streams i.e. upstream and downstream. RTP runs over a UDP. The following metrics are considered:

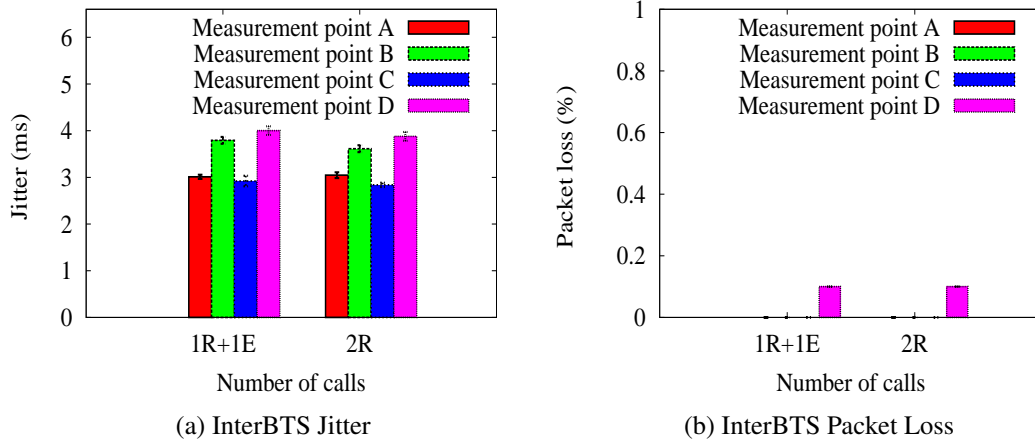

Figure 4.8: Equivalence of real and emulated calls for InterBTS setup in quiet environment.

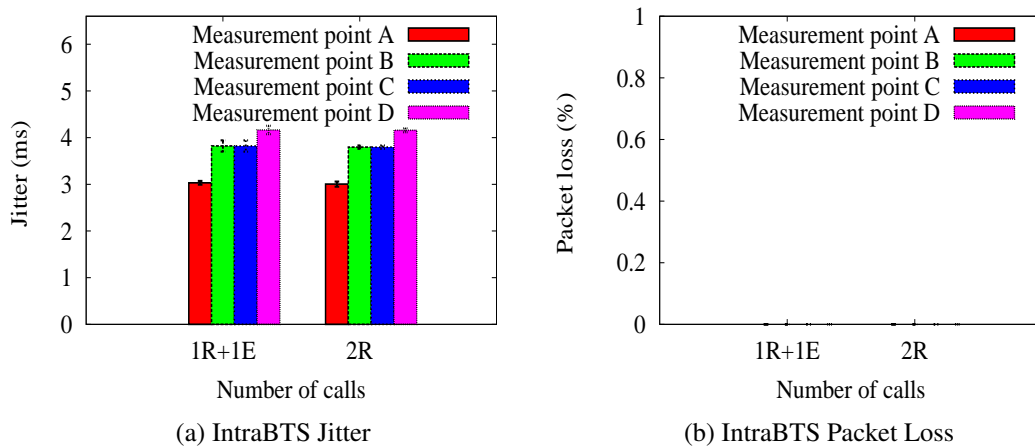

Figure 4.9: Equivalence of real and emulated calls for IntraBTS setup in quiet environment.

4.4.6.1 Jitter

The mean deviation of the difference in packet arrival time at the receiver compared to the sender and measured in millisecond (ms). It is calculated as [116]

$$J(i) = J(i - 1) + \frac{(|D(i - 1, i)|) - J(i - 1)}{16} \quad (4.1)$$

where D is the *difference in RTP timestamp and RTP time of arrival of a packet*. The division by 16 is to reduce the effects of large random changes.

4.4.6.2 Packet Loss

The number of packets lost compared to number of packets sent, based on RTP sequence numbers.

4.4.6.3 Throughput

The number of bits successfully received at the receiver per second.

4.4.6.4 Mean Opinion Score (MOS)

MOS can be used to estimate voice quality as perceived by the users and depends upon the codec being used, which in our case is GSM-FR (6.10). We have used E-model [117] to evaluate MOS, because this model involves codec type and packet loss. The maximum MOS provided by GSM FR is 3.46 for 0% packet loss. MOS is expressed in a range from 1 (worst) to 5 (best). MOS can be calculated from E-Model [117] as

$$MOS = 1 + (R \times 0.035) + R \times (100 - R) \times (R - 60) \times (7 \times 10^{-6}) \quad (4.2)$$

where R is the *rating factor*, which is calculated as a function of the *effective equipment impairment factor* I_{eff} ,

$$R = 93.2 - I_{eff} \quad (4.3)$$

The I_{eff} is dependent on packet loss and can be written as

$$I_{eff} = I_e + (95 - I_e) \times \frac{ppl}{ppl + bpl} \quad (4.4)$$

where I_e is the impairment factor for 0% packet loss. bpl is the packet loss robustness factor and ppl is packet loss in percentage for each voice stream. The I_e and bpl for GSM FR 6.10 are 23 and 46 [118].

4.5 Performance Evaluation

To evaluate the capacity of the link, we vary the number of calls (by increasing the number of emulated calls), and measure the impact on jitter, packet loss, throughput

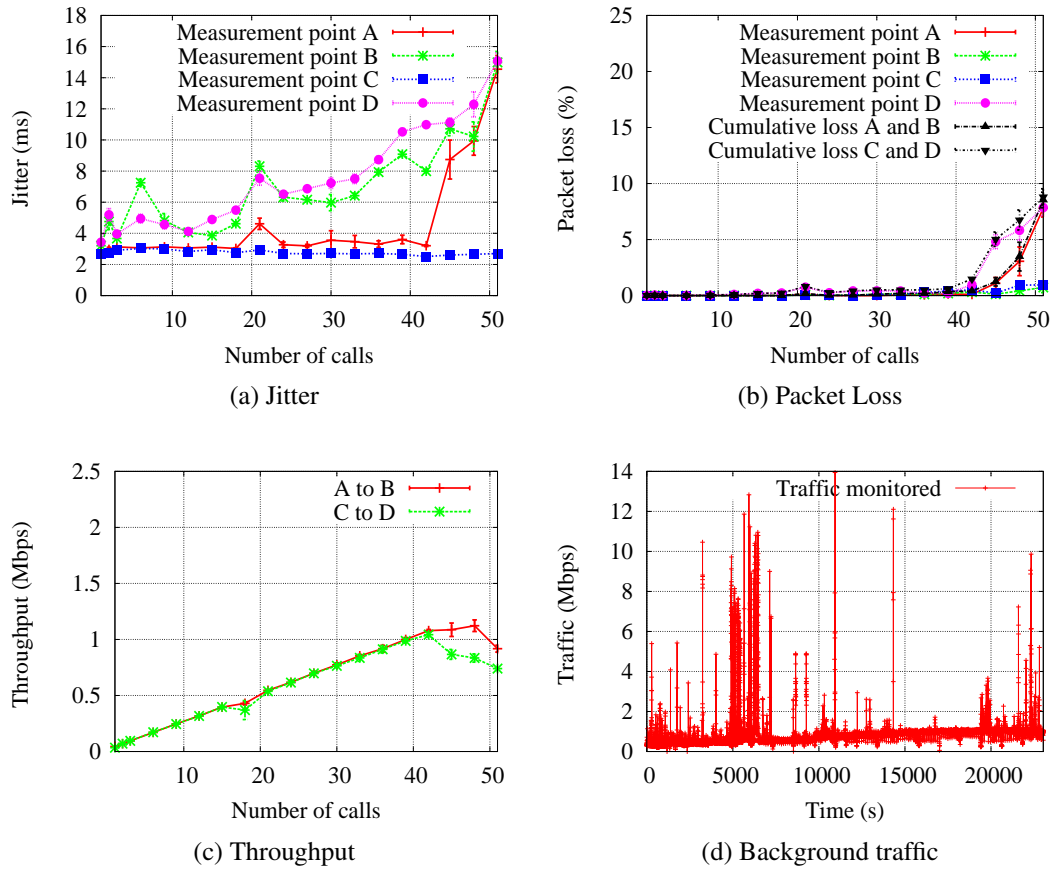

Figure 4.10: InterBTS experiments conducted in quiet environment.

and MOS. We run 10 trials of 2 minutes each for every call and take the average of all trials and establish a 95% confidence interval.

The first set of experiments are conducted in the quiet environment, with results shown in Figure 4.10 and 4.11 for InterBTS and IntraBTS cases. Measurement points B and D capture performance statistics (outgoing traffic) for the wireless backhaul link, while points A and C capture statistics (incoming traffic) for the internal system, i.e., laptops shown in Figure 4.6 and 4.7. According to Cisco VoIP analysis [119] [8], for acceptable call quality, the average one way jitter should be less than 30 ms. For up to 50 calls, the one-way traffic jitter results are far lower than the 30 ms for both scenarios. Packet loss should ideally be less than 1%, until 5% voice quality is considered good and until 10% delayed speech is observed. For the InterBTS case, 50 simultaneous calls can be supported; however, in IntraBTS case, for 25 or more calls, packet loss becomes too high. This is reflected in the throughput values. As the number of calls increases, the total throughput rises linearly, until close to 50 calls for InterBTS, and until 24 calls for IntraBTS, at which point the communication becomes saturated, and throughput stabilises or declines. Throughout the quiet environment experiments, the

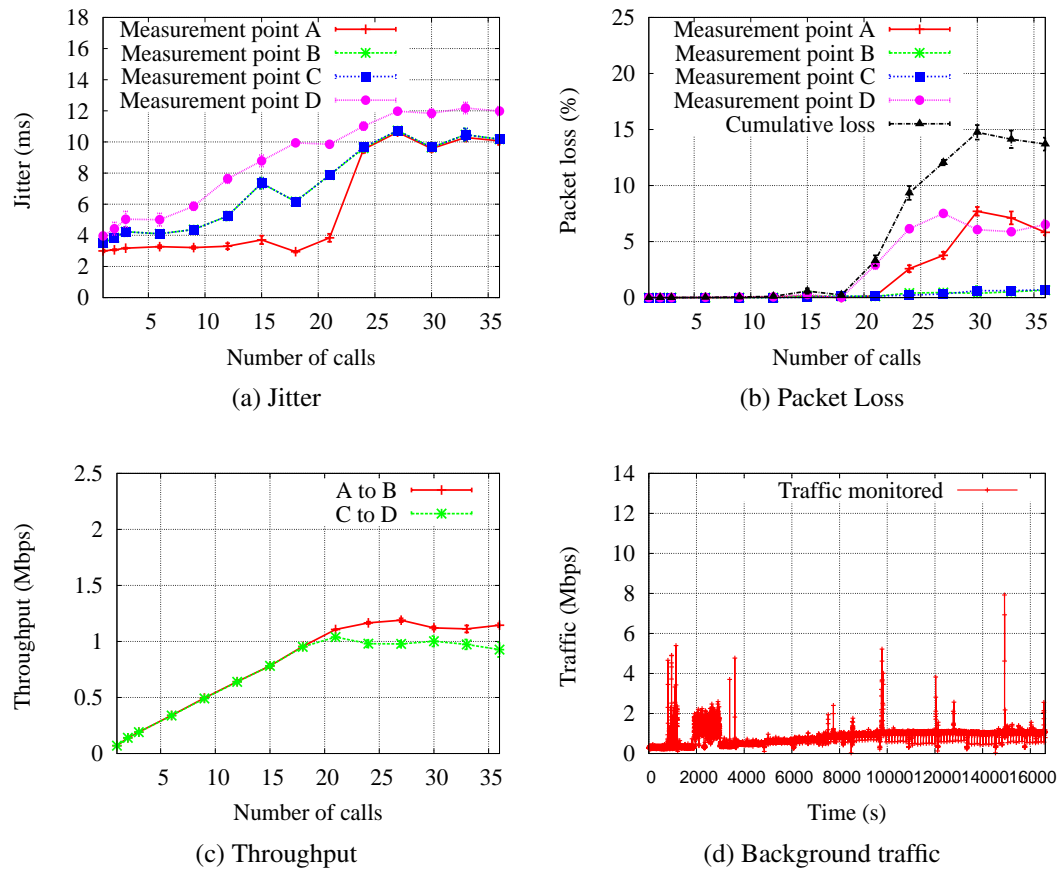

Figure 4.11: IntraBTS experiments conducted in quiet environment.

background traffic remains predominantly below 2 Mbps, with occasional spikes. The sustained increase at 5000s for the InterBTS correspond to the small increases in jitter and packet loss at 20 calls. The MOS for both scenarios can be seen in Figure 4.14. An MOS below 2.5 MOS is considered to indicate a poor quality call. MOS for the quiet environment is above 3 for the InterBTS scenario until 50 calls, and for the IntraBTS remains above 3 until 24 calls. These results indicate that the combination of a software-defined radio front end and a wireless backhaul is able to support a significant number of GSM voice calls, and thus in principle the technology is feasible for deployment as part of a disaster response solution. Up to 50 calls can be maintained across a single link when one of the UEs is communicating with a front end located on the same machine as the SIP server. When both UEs must share the same wireless backhaul to reach the SIP server, the effective capacity drops by a factor of 2.

The above experiments are conducted when external wireless activity was low. However, in a disaster scenario, we cannot control the external activity, and it is likely that other networks will be established, or existing equipment may be transmitting. Therefore, we also conduct evaluation when the spectrum is more heavily occupied, as shown in

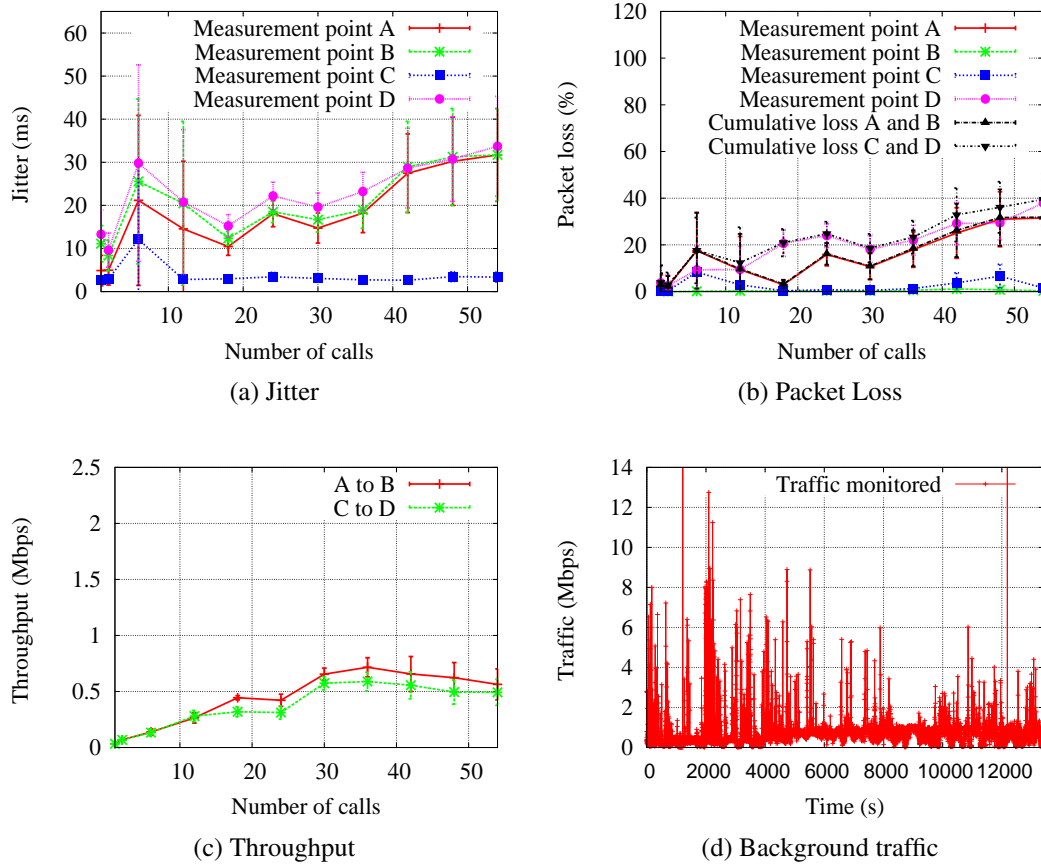

Figure 4.12: InterBTS experiments conducted in noisy environment.

Figure 4.12 and 4.13. The increase in the background traffic means increased contention for wireless access. In the InterBTS case, jitter is observed to be approximately 5 times higher than in the quiet environment for even a small number of calls, although it still remains below the threshold of 30ms until close to 50 calls. However, packet loss rises almost immediately to 20%, and thus very few calls are successful. For the IntraBTS case, jitter rises above 30ms almost immediately, and the accumulated packet loss immediately exceeds 20%, and in these experiments acceptable quality was obtained for only a single call. The MOS (Figure 4.14) for the InterBTS case is noticeably lower than for the quiet environment, and becomes consistently unacceptable after 10 calls. For the IntraBTS case, the MOS value is below 2 for all calls.

It is noted that the packet loss values are significantly higher at measurement points A and D, and relatively low at points B and C. It is believed that this is because of the presence of an interfering access point closer to BTS2. From tracing the packets, it appears that when the WiFi transceiver on that laptop listens to the channel, it is frequently unable to find a clear slot to transmit, even though the receiver at the other laptop is relatively interference free. Because of this, the transmitter backs off, and

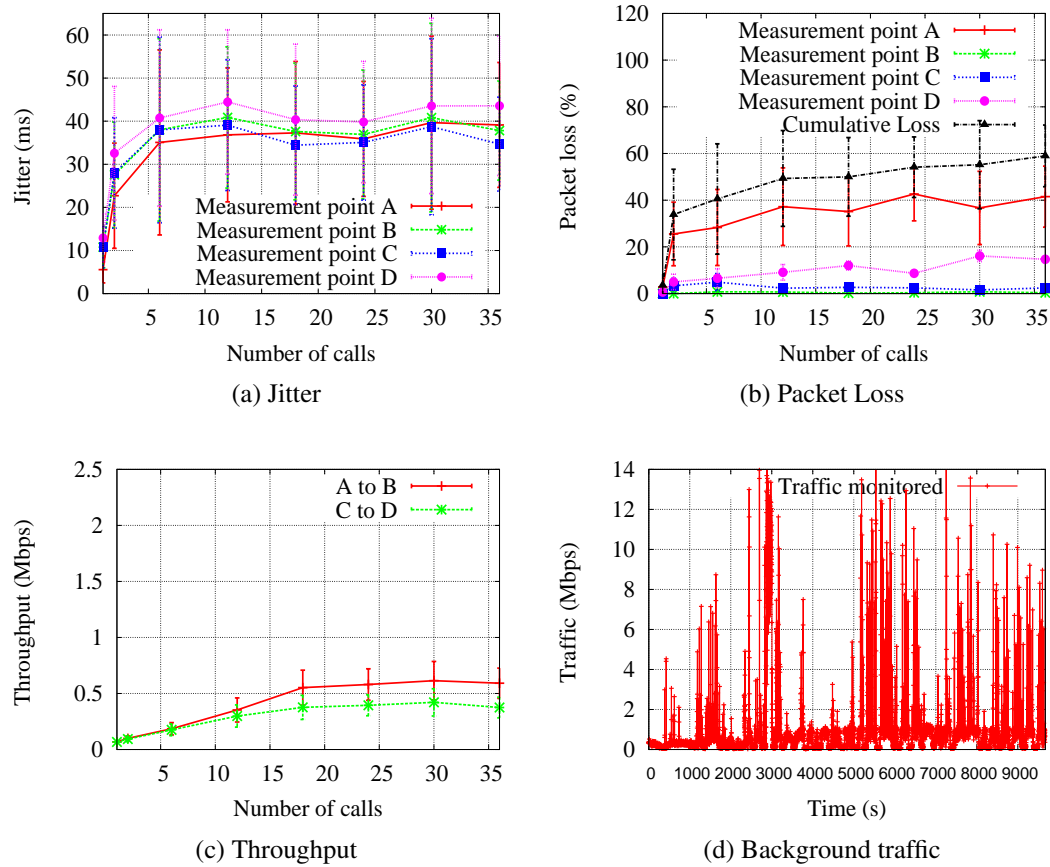

Figure 4.13: IntraBTS experiments conducted in noisy environment.

the internal queues begin to fill up, and thus new packets are being dropped in the system before they reach the transmitter. For the reverse direction, the transceiver at C is able to transmit, but collisions are happening at the receiver at point D, thus requiring frequent retransmissions. The effect is magnified at point A in the IntraBTS case because of the doubled flow.

These results demonstrate that the system is not stable in the presence of background interference, and that the system can quickly degrade to the point where it is unable to support more than 1 or 2 simultaneous calls. The performance degradation is due to the wireless backhaul, while the software radio front end is capable of supporting the communication. It is speculated that backhaul performance could be partially restored by switching channels. However, in a disaster scenario, we will have no prior knowledge of spectrum use, and we will have little control over other devices in the area which may appear without warning. Thus it is believed that this indicates that there is a need to utilise cognitive radio techniques, both for the enhanced sensing and spectrum agility, and for the ability to exploit white spaces in licensed spectrum. In particular, if the existing network infrastructure is partially destroyed, then it is likely

that licensed spectrum is no longer being used. In addition, it is believed that the lower frequency bands than those for 802.11 will allow us to extend the range of the backhaul communication.

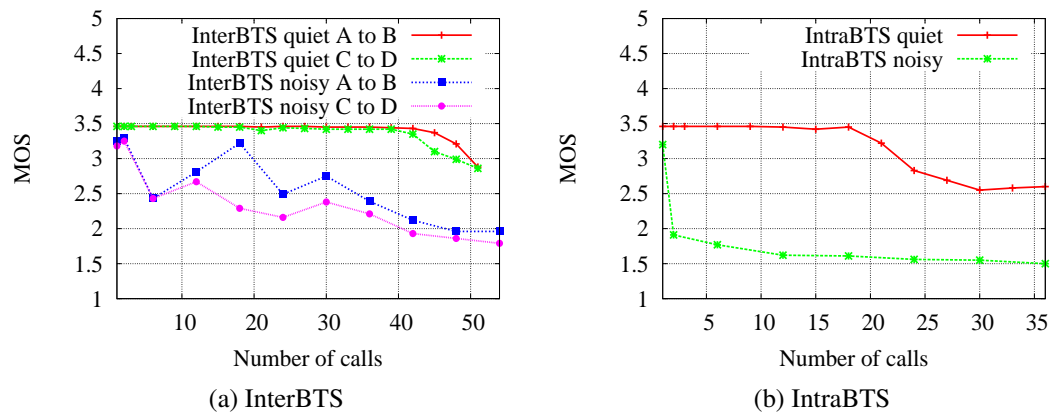

Figure 4.14: Mean opinion score.

4.6 Discussion

In this chapter, the applicability and feasibility of a software-defined radio are analyzed for a lightweight, rapidly deployable, robust and reliable solution, together with back-end QoS support. It is concluded that the system can support a large number of calls with sufficient quality. However, when the interference is high on the selected link, it became a bottleneck and able to support only a few calls. The SDR in itself is able to provide services like GSM or LTE, and could extend coverage area using a multi-hop configuration connected using wireless links. Therefore, the channels with high utilization or interference must be avoided using a free or dedicated licensed channel, which is difficult to achieve in disasters due to the unknown environment and primary radio activity. Instead, the use of dynamic spectrum access could be exploited to find a free channel. If such system is to be deployed in a disaster, there are some other challenges which needs to be addressed to make it work in a self-organized and adaptive manner. These challenges include:

- information gathering, like channel availability and accessibility,
- discovery of other operational or partially damaged networks,
- environment discovery with primary user activity, and
- discovery of other nodes.

Among other challenges, considering primary user activity is also important to protect the surviving primary users like (cellular network or radar transmission). The detection of primary user activity demands the channel is not used for some time, which can increase the network setup delay. However, if primary user activity is not considered, then the secondary user's communication can disturb the ongoing primary user communications by causing harmful interference. Discovering the nodes in the disaster scenario and establishing a rendezvous among them is the foremost challenge to setting up a disaster response. Therefore, in the next Chapter, a rendezvous problem is addressed for the unknown environments, where the channels and primary user activity information is also considered as unknown.

4.7 Chapter conclusion

In disaster response, communication is vital, and yet in many scenarios it is possible that much of the communications infrastructure is destroyed. In these cases, it is critical that a communications network is deployed quickly; this network should offer multiple services to legacy devices, should interoperate with whatever remains of the existing infrastructure, and should provide service until more stable solutions can be deployed. A hybrid software-defined radio access and 802.11 backhaul prototype is designed, implemented and evaluated for rapid deployment to provide cost-effective voice services. The prototype is evaluated in an open environment, and it is shown that the prototype can support over 40 simultaneous calls across two base stations. However, the wireless backhaul is subject to interference from external transmitters, and therefore in noisier environments the call quality quickly degrades, and the prototype can support fewer than 5 calls. After a disaster it can be expected that considerable portions of the licensed spectrum will lay idle. It is concluded that for supporting higher number of calls, the bottleneck is the backhaul link which is due to high utilization of an unlicensed channel. Therefore, to provide sufficient quality of service when there is serious interference in the unlicensed bands, it is desirable to exploit that idle licensed spectrum for backhaul between base stations, using cognitive radio techniques.

Chapter 5

An Extended Modular Clock blind rendezvous Protocol

5.1 Introduction

In many disaster scenarios, communication networks are vital for ensuring efficient and effective first response; however, the disaster may have caused significant damage to the existing communication infrastructure. A cognitive radio (CR) can provide an effective solution for creating an initial disaster response network (DRN) until a more permanent network is re-established [5]. It can sense what links exist of the remaining infrastructure, what spectrum is available, and exploit the spectrum opportunistically while avoiding the primary radio (PR) activity. Given the nature of the disaster, with unknown PR activity and spectrum spatial diversity, each CR node must sense the spectrum independently rather than relying on spectrum databases which might not be available in disasters, and must rendezvous with each other on available channels. This creates the challenging problem of achieving rendezvous in an unknown environment with unknown PR activity.

Rendezvous as discussed in Chapter 3, can be achieved when two radios complete a handshake mechanism. This assumes that the two radios are on the same channel, within transmission range of each other, they coincide on the channel for a sufficient time period and that the channel has no detectable PR activity or excessive interference for the radios over that time period. When there is no predefined schedule for visiting channels and no common control channel, this is known as the blind rendezvous problem. The blind rendezvous problem is challenging due to unknown information of nodes, available channels, nodes starting times and the environment in which they op-

erate. The existing blind rendezvous strategies [40, 48, 49] strictly focus on achieving some form of rendezvous guarantee. This guarantee only applies when nodes select different rate values (the channel hopping factor). It also assumes a set of channels on which there is no PR activity or external interference. The unpredictable arrivals of PRs on these channels invalidates the guarantee and may result in the CR nodes causing unacceptable interference to PRs. Therefore, an Extended Modular Clock Algorithm (EMCA) is proposed which abandons the rendezvous guarantee, but has a shorter rendezvous cycle time, and is intended to reduce the average time to rendezvous (TTR). To handle the PR traffic, a Listen Before Talk (LBT) approach is used with the aim to reduce the harmful interference. In addition, an information exchange mechanism is also proposed as a part of handshake mechanism for the multi-node problem, to further reduce the TTR. The EMCA is designed in this Chapter mainly for single hop networks with known number of nodes. The more realistic scenario of unknown number of nodes will be discussed in Chapter 7.

5.1.1 Main contributions

The main contributions of this Chapter are;

1. an Extended Modular Clock Algorithm for single hop scenario with known number of nodes, to reduce the time to rendezvous for unknown environments with PR activity;
2. a cognitive radio simulator with PR activity model to analyse the behavior of a CR for the proposed rendezvous protocol;
3. a neighbour exchange mechanism to expedite the rendezvous process for multiple CR nodes; and
4. a performance evaluation of EMCA over different existing blind rendezvous strategies and primary radio activity patterns.

5.2 System Model and Assumptions

A distributed Cognitive Radio Network (CRN) [21] is considered for a disaster response without any centralized controller with N secondary users (or CRs) in an $L \times L$ network area. Each CR i (where $1 \leq i \leq N$) is equipped with a single wireless interface and each CR node can operate only on one channel at a time.

The total channels available in the network are G , where $G = \{1, 2, 3, \dots, n\}$. Due to spatial diversity of channels and different localized primary radios at different geographical locations, each node may perceive different channels [120–122]. Each node maintains its Available Channels Set (m_i) differently, where m_i is a subset of G . The common channels (M) between any two nodes may vary, which may be different for each node, and so it is assumed that there exist atleast one common channel between them (i.e., $M \geq 1$).

Due to spatial diversity of channels and hardware limitations of radio transceivers, different nodes may have different subsets of spectrum bands available for communication. These subsets of spectrum bands are referred to here as Available Channels Sets (ACS). It is assumed that G is the set of all channels available in the network, where $G = \{1, 2, 3, \dots, n\}$. Each ACS_i is a subset of G .

For quick channel selection decision for a rendezvous attempt, a CR can perform fast sensing, as suggested in IEEE 802.22 standard of 1 ms [6, 123]. A perfect channel sensing model is considered in which the sensing results are assumed without any errors like miss detection or false alarm.

A time slotted system is assumed with fixed timeslot (TS) duration for the rendezvous algorithm working, in which the CR nodes are not synchronised with each other and with PRs. Further, CR nodes are unaware of the starting times of all other nodes. Therefore, rendezvous is possible between two nodes only when their TSs overlap for sufficient amount of time to exchange beacons. Asynchronous timeslots were shown to be beneficial for reducing TTR in [124]. For beacon transmissions, a broadcast transmission is adopted where each node broadcasts its beacon to attempt a rendezvous.

This Chapter assumes a static scenario, where CR node locations are fixed, all nodes are within transmission range of each other and each node is aware of the total number of nodes in the network. These assumptions will be revisited in subsequent Chapters.

5.3 Extended Modular Clock Algorithm (EMCA)

5.3.1 Overview

EMCA is a blind rendezvous algorithm which is based on the Modular Clock Algorithm (MCA) [40] which is already presented in Chapter 3.

- i , is the CR node id.

- r_i (rate), is the step length by which a node i jumps from one channel to another.
- m_i , is the total number of channels in Available Channel Set (ACS) of node i .
- P_i , is the lowest prime number greater than or equal to m_i .
- t_i , is the timeslot of node i and is the duration for which a node stays on a channel selected by using a rendezvous algorithm.
- j_i , is the index value or label for channel position in the ACS of node i .
- $c_{i,j}$, is the channel at index j of node i 's ACS.

MCA EXAMPLE

	initial index (j_i^t)	rate (r_i)	prime number (p_i)	current channel index $j_i^{t+1} = (j_i + r_i) \% p_i$	if $j_i^{t+1} > m_i$ ($j_i^{t+1} \% m_i$)	selected channel c_j
Node 1	2	2	5	$(2 + 2) \% 5 = 4$	$4 \% 4 = 0$	4
	2	2	5	$(4 + 2) \% 5 = 1$		5
	2	2	5	$(1 + 2) \% 5 = 3$		7
	2	2	5	$(3 + 2) \% 5 = 0$		4
	2	2	5	$(0 + 2) \% 5 = 2$		6
	2	2	5	$(2 + 2) \% 5 = 4$	$4 \% 4 = 0$	4
	2	2	5	$(4 + 2) \% 5 = 1$		5
	2	2	5	$(1 + 2) \% 5 = 3$		7
	2	2	5	$(3 + 2) \% 5 = 0$		4
Node 2	0	1	5	$(0 + 1) \% 5 = 1$		7
	1	1	5	$(1 + 1) \% 5 = 2$		8
	1	1	5	$(2 + 1) \% 5 = 3$		9
	1	1	5	$(3 + 1) \% 5 = 4$	$4 \% 4 = 0$	6
	1	1	5	$(4 + 1) \% 5 = 0$		6
	1	1	5	$(0 + 1) \% 5 = 1$		7
	1	1	5	$(1 + 1) \% 5 = 2$		8
	1	1	5	$(2 + 1) \% 5 = 3$		9
	1	1	5	$(3 + 1) \% 5 = 4$	$4 \% 4 = 0$	6
1	1	5	$(4 + 1) \% 5 = 0$		6	

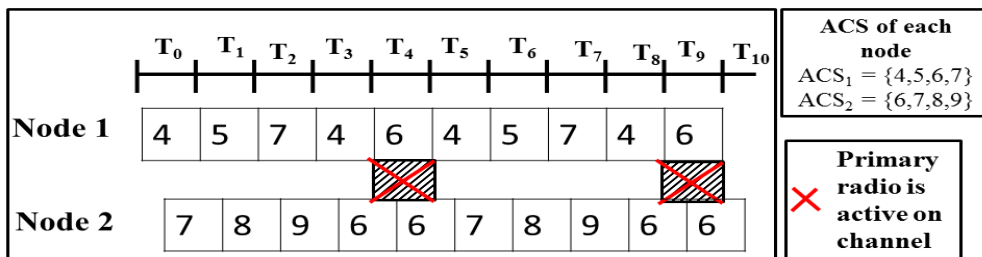

Figure 5.1: Example of modular clock algorithm.

An example of MCA is shown in Figure 5.1, for the explanation and comparison with EMCA. The basic principle of MCA is to hop among channels with r_i (rate value) for $2P$ timeslots or until rendezvous occur, to guarantee rendezvous which occurs only when the other node hops using a different rate value. P represents the duration of a rendezvous cycle in timeslots and is equal to the lowest prime number greater than or

equal to m_i . However, MCA does not consider a PR activity, due to which the guarantee within $2P$ timeslots cannot be achieved. Therefore, it wastes time by hopping unnecessarily just to achieve the rendezvous guarantee. It remaps also the channels with an index value greater than m_i , with available channels of the initial order, which is a biased channel selection, as some channels might not be available to other nodes, which can also waste rendezvous attempts and time. Finally, MCA is designed for symmetric channels. It is shown in Figure 5.1, that the rate value continues for $2P$ timeslots (i.e., $(2 \times 5 = 10)$ timeslots). Even if PR is present on channel 6, it continues to achieve the rendezvous guarantee, which is unnecessary, because if PR is detected on a channel, then that channel must also be avoided for some time.

5.3.2 EMCA Operation

The EMCA algorithm initializes by choosing an initial index and rate value randomly, as shown in Algorithm 1. The rate value remains the same for the duration of one rendezvous cycle with length P_i timeslots, whereas in MCA the rendezvous cycle length is $2P$ timeslots. If rendezvous does not occur within P_i timeslots, then a new r_i will be selected again randomly from $[0, p_i)$. At each iteration, the next index value j_i will be calculated using $\text{mod}(P_i)$. If the new channel index j_i is within m_i then that channel $c_{i,j}$ will be selected, which is the channel at index j_i on node i 's ACS. Otherwise, if next index value is greater than $m_i - 1$, then index value will be remapped randomly (out of m_i) to select a channel from ACS_i . The index can exceed $m_i - 1$ due to the gap between m_i and P_i . Unlike in MCA, the index j_i if greater than $m_i - 1$ is being remapped again using mod function between 0 and $m_i - 1$. In each timeslot t_i , multiple beacon transmissions occur to attempt a rendezvous, shown in Algorithm 1, between Lines 17 and 26. For PR activity handling before every transmission, a basic "Listen Before Talk" approach is used.

An example of EMCA is shown in Figure 5.2. As different from MCA (Figure 5.1), it changes the rate value randomly after P timeslots, if rendezvous does not occur within P timeslots. In the first rendezvous cycle, the nodes got the opportunity to attempt rendezvous, however, due to PR activity on channel 6, the rendezvous could not be achieved. Therefore, the EMCA tries the new rate value instead of waiting for another P timeslots which increase the chance to at least attempt a rendezvous on another channel, which is shown in the example as achieved on channel 7 of second rendezvous cycle in blue color. It also remaps channels randomly as different from MCA (Figure 5.1), which also increases the chance to achieve rendezvous. When the

initial order channels are not common among the nodes or not available to some nodes, the rendezvous cannot be achieved. This is also shown in Figure 5.2, that in second rendezvous cycle of node 1, it selects a random index 3 which resulted in a successful rendezvous.

EMCA EXAMPLE

	initial index (j_i^t)	rate (r_i)	prime number (p_i)	current channel index $j_i^{t+1} = (j_i + r_i) \% p_i$	if $j_i^{t+1} > m_i$ (random[0, m_i])	selected channel c_j
Node 1	2	2	5	$(2 + 2) \% 5 = 4$	2 (ch index)	6
		2	5	$(4 + 2) \% 5 = 1$		5
		2	5	$(1 + 2) \% 5 = 3$		7
		2	5	$(3 + 2) \% 5 = 0$		4
		2	5	$(0 + 2) \% 5 = 2$		6
		1	5	$(2 + 1) \% 5 = 3$		7
		1	5	$(3 + 1) \% 5 = 4$	3 (ch index)	7
		1	5	$(4 + 1) \% 5 = 0$		4
		1	5	$(0 + 1) \% 5 = 1$		5
Node 2	0	1	5	$(0 + 1) \% 5 = 1$		7
		1	5	$(1 + 1) \% 5 = 2$		8
		1	5	$(2 + 1) \% 5 = 3$		9
		1	5	$(3 + 1) \% 5 = 4$	1 (ch index)	7
		1	5	$(4 + 1) \% 5 = 0$		6
		3	5	$(0 + 3) \% 5 = 3$		9
		3	5	$(3 + 3) \% 5 = 1$		7
		3	5	$(1 + 3) \% 5 = 4$	2 (ch index)	8
		3	5	$(4 + 3) \% 5 = 2$		8
	3	5	$(2 + 3) \% 5 = 0$		6	

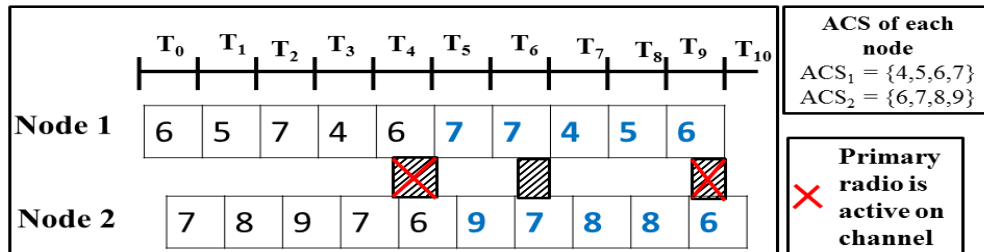

Figure 5.2: Example of extended modular clock algorithm.

5.3.3 Listen Before Talk (LBT) Approach

Unlike MCA, EMCA works in collaboration with a PR activity handling procedure and uses an LBT approach for this purpose, with an intention to reduce the harmful interference towards a PR. In LBT, a channel status will be checked before every beacon transmission, and transmission will not occur, if PR activity is detected. A node will attempt a rendezvous only when the channel is sensed as free; otherwise, rendezvous will not be attempted.

Algorithm 1 Extended Modular Clock Algorithm

```

1: observe  $m_i$ , total number of channels in  $ACS_i$ 
2: calculate  $P_i$ , the prime number greater than or equal to  $m_i$ 
3: choose initial  $j_i^{t_i} = rand[0, m_i)$ 
4: choose initial  $r_i$  from  $[0, P_i)$  randomly
5: Initialize,  $t_i = 0$ 
6: while node  $i$  not rendezvous with all nodes do
7:   if  $t_i \geq P_i$  then
8:     choose  $r_i$  from  $[0, P_i)$  randomly
9:      $t_i = 0$ 
10:  end if
11:   $j_i^{t_i+1} = (j_i^{t_i} + r_i) \bmod P_i$ 
12:  if  $j_i^{t_i+1} < m_i$  then
13:     $c = C_{i, j_i^{t_i+1}}$ 
14:  else
15:     $c = C_{i, rand([0, m_i])}$ 
16:  end if
17:  Initialize,  $beacon_i = 0$ 
18:  while  $beacon_i \neq 5$  do
19:    if channel  $c$  is occupied then
20:      Do not attempt rendezvous on  $c$ 
21:    else
22:      Attempt rendezvous on  $c$ 
23:    end if
24:    wait for next scheduled beacon transmission
25:     $beacon_i = beacon_i + 1$ 
26:  end while
27:  wait for timeslot to end
28:   $t_i = t_i + 1$ 
29: end while

```

5.3.4 Message Passing based Handshake Mechanism

For a successful rendezvous, two nodes must complete a handshake process. A beaconing mechanism is proposed, in which nodes embed into the beacon a list of neighbouring nodes they have overheard. As shown in Figure 5.3, if two nodes find their own IDs in each other's beacons, then it is assumed that rendezvous has been completed. In this way rendezvous can be achieved faster than by using a 4-way handshake process without any neighbour information exchange, as shown in Figure 5.4. For example, when Node B receives a beacon from A it will send an ACK. A now knows that B has received its beacon, and adds B to its neighbour list. If B receives A's next beacon, it will discover its own ID in the list. It knows that A has received its ACK, and can add A to its neighbour list.

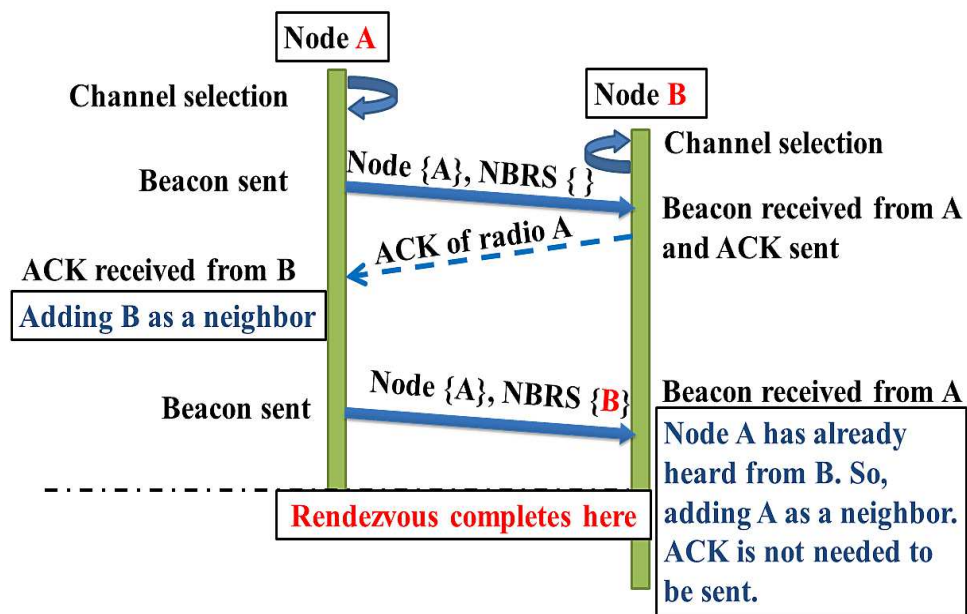

Figure 5.3: neighbour information Passing Mechanism and 3-way handshake.

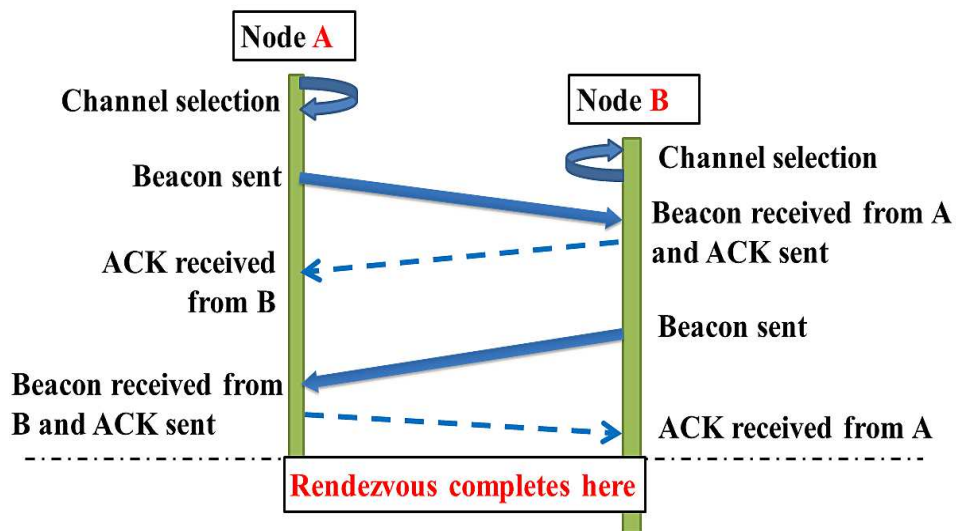

Figure 5.4: Four way handshake mechanism.

5.3.5 Difference with existing approaches

The main advantages of EMCA and its difference with existing blind rendezvous strategies are,

- Its rendezvous cycle is short (i.e., P timeslots), for which a node hops among channels using a particular r_i rate value in each timeslot until P timeslots.

- It remaps those channels randomly from m_i , whose resulting index j_i exceeds the $m_i - 1$ limit of available number of channels to avoid biased selection of initial order channels.
- It considers channels with PR activity and makes sure a primary user is not active on a particular channel before attempting a rendezvous.
- It contains a handshake mechanism for a successful rendezvous.
- It passes the neighbour information in a beacon to expedite the rendezvous process.

5.3.5.1 Short rendezvous cycle

The existing strategies guarantee the rendezvous when the rate values are chosen differently by each node and when there is no PR activity or interference on the channels. To ensure the rendezvous guarantee, their rendezvous cycles are long. The MCA case is considered here, in which rendezvous is guaranteed (if $r_1 \neq r_2$) and rendezvous cycle length is set to $2P$ timeslots due to possible different starting times of two radios. Since they assume channels with no PR activity, the PR effect is not accounted. If PR appears at the time of beacon transmission and CR avoids the rendezvous attempt due to PR appearance, the rendezvous opportunity can be missed which results in no rendezvous in that particular rendezvous cycle. In this case, following the same rate value for $2P$ timeslots will increase the TTR. Since the rendezvous guarantee cannot be achieved, even if two radios are on the same channel in the same timeslot, because of unknown PR activity, the limit is reduced to allow a search of all channels, but at faster rate re-selection, in the hope of speeding up the time to rendezvous. We propose to reduce the rendezvous cycle length to P . As we are giving away half of the rendezvous cycle length, it is important to determine how often rendezvous occurs in the second half of $2P$ timeslots (i.e., last P timeslots) of MCA. We simulated a scenario (simulation setup will be discussed in Section 5.4 in detail) of two nodes with same channels (10 and 20) for 1000 simulation runs, to find out the rendezvous occurrence distribution in each half of $2P$ timeslots (rendezvous cycle length of MCA). Figure 5.5 illustrates the results, which show that for 10 channels (Figure 5.5a) 99.45% times rendezvous occurred in the first half of $2P$ timeslots and only 0.55% times they occurred in the second half of $2P$ timeslots, which we propose to compromise. For 10 channels the P value is 11 timeslots and $2P$ is 22 timeslots. For 20 channels P is 23 and $2P$ is 46 timeslots. Figure 5.5b shows the results for 20 channels, and the percentage ratio appeared again in favor of first half of $2P$ timeslots with 99.95% times rendezvous

occurred in the first half of $2P$ timeslots, which shows that we can give out half of the timeslots with confidence to re-select the rate value earlier to reduce the time to rendezvous.

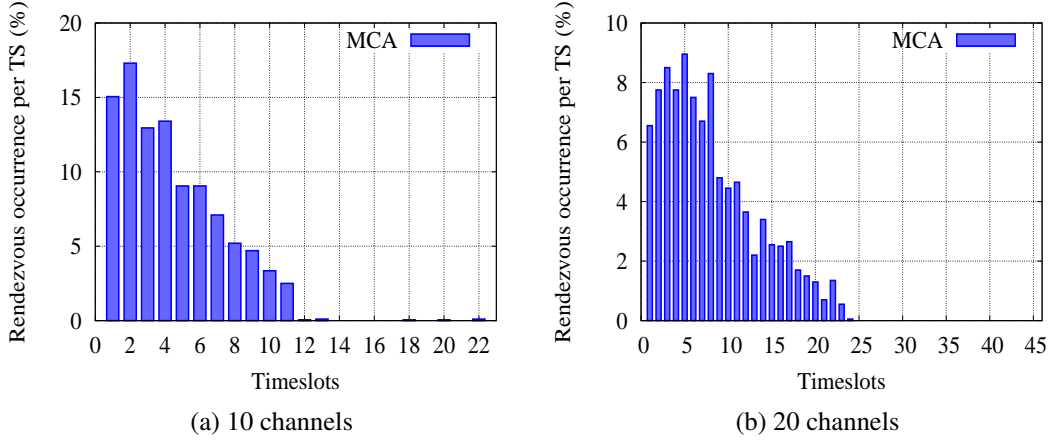

Figure 5.5: Rendezvous occurrence distribution among $2P$ timeslots of MCA rendezvous cycle length.

5.3.5.2 Biased channel selection

Depending on the total number of channels m_i , there can be a gap between m_i and P_i , because P_i is selected as a prime number larger than or equal to m_i (For example, if m_i is 8 then P_i will be 11). Due to next index calculation in Line 11 of Algorithm 1, the resulting index can exceed the $m_i - 1$ limit of channel indexes. To overcome this situation and to wrap it again within $m_i - 1$ limit, MCA remaps the index with another mod function (as $j_i^{t_i+1} \bmod(m_i)$) between 0 and $m_i - 1$, which results in biased channel selection from the initial order of ACS_i . For example, if next index calculation (Line 11 of Algorithm 1), results in 10 and m_i is 7, then 10^{th} index value is surely higher than the limit m_i . If, another mod function is used ($j_i^{t_i+1} \bmod(m_i)$) as in MCA) the index value will be $10 \bmod (7)$ which results in 3. Therefore, the channel at 3^{rd} index value will be selected. Such biased channel selection can increase the time to rendezvous if channels are not shared (same) between two nodes. However, in EMCA the channels are remapped randomly from ACS_i , when the resulting index value exceeds the $m_i - 1$ limit. The test for rendezvous occurrence distribution per timeslot is repeated with random remap, to see the effect on rendezvous occurrence distribution in each half of $2P$ rendezvous cycle length. The results show that for 10 channels case (Figure 5.6a) 97.75% times rendezvous occurred in the first half of $2P$ timeslots and only 2.25% times they occurred in the second half. Similarly, for 20 channels

case (Figure 5.6b) about 98.50% times rendezvous occurred in the first half and only 1.50% times rendezvous occurred in the second half. This shows that even with random replacement, the rendezvous occurrence within first P timeslots is not affected as compared to the results without channel remapping, shown in Figure 5.5.

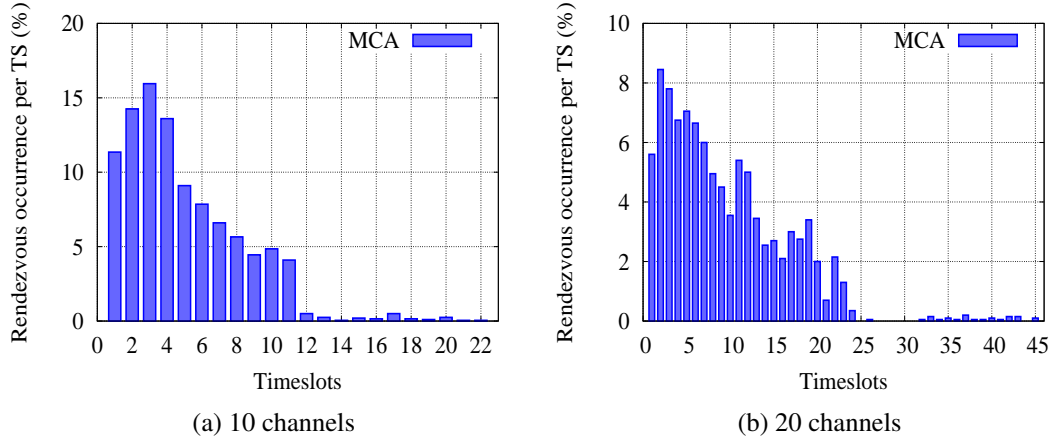

Figure 5.6: Rendezvous occurrence distribution among $2P$ timeslots of MCA rendezvous cycle length with random channel remap.

5.3.5.3 PR activity consideration and rendezvous guarantee

The existing rendezvous strategies assume the selected channels are always available with no PR activity. However, in disaster situations, even the selected channels might not be available in the next time instance due to sudden PR appearance. Therefore, it is essential to identify those channels to establish a successful rendezvous between nodes; and to avoid creating harmful interference towards the PR systems. A CR is originally meant to identify and vacate those channels on which a PR signal is detected. To cope with this, the functionality of checking the medium is included before every rendezvous attempt (i.e., a beacon transmission) for all rendezvous strategies. The initial results proved the performance degradation of rendezvous strategy and loss of rendezvous guarantee due to unknown PR activity. A scenario is simulated here of two nodes and shared channels (10 same channels) for MCA, EMCA and JS (MMCA is not included as it is not designed for shared channels). The existing rendezvous strategies are meant to provide rendezvous guarantee (if $r_1 \neq r_2$) within a period of rendezvous cycle length. Therefore, the total number of rendezvous cycles are measured in which rendezvous did not occur due to PR appearance. The results are shown in Table 5.1, which confirms that with increasing PR activity for all rendezvous strategies, the number of cycles in which rendezvous did not occur increases as well. In Table 5.1, the

percentage of the number of rendezvous cycles is shown in which rendezvous did not occur at all among the total number of rendezvous cycles used to achieve a rendezvous. For each rendezvous strategy, the percentage values are different due to their different rendezvous cycle lengths (i.e., the rendezvous cycle lengths for MCA, EMCA, and JS are $2P$, P and $3P$). The results also show that with increasing PR activity the nodes hop unnecessarily on different channels if rendezvous opportunity is missed due to a PR appearance in a particular rendezvous cycle. For zero PR activity, the percentage of rendezvous cycles without a successful rendezvous is low, which is due to the unlucky cases in which rates were picked as same randomly. However, with increasing PR activity, as can be seen for MCA, EMCA, and JS, the percentage increases also. EMCA percentage as compared to MCA is high for higher PR activities, due to half of its rendezvous cycle length. For JS, the rendezvous cycle length is $3P$, and for zero PR activity, it appears as only one time rendezvous cycle is passed without the successful rendezvous. However, with an increase in PR activity, its rendezvous cycles percentage without any successful rendezvous increased to 17.69% and 67.30% for 50% and 85% PR activity. Therefore, from the results, it is concluded that due to unknown PR activity the guarantee can be lost and time to rendezvous can increase also, which can increase the network setup delay.

Table 5.1: Percentage of rendezvous non-occurrence in overall rendezvous cycles (shared channels case).

	PR activity %	Rendezvous non-occurrence (%)
MCA	0	16.80
	50	39.25
	85	61.18
EMCA	0	14.97
	50	60.33
	85	78.31
JS	0	5.70
	50	17.70
	85	67.31

5.3.5.4 Channels and multiple nodes

By incorporating random remapping of channels and short rendezvous cycle, EMCA is capable of giving a better outcome in terms of TTR for both similar and different channels set. It is able to achieve pairwise rendezvous among multiple nodes.

5.4 Simulation Environment

In this section, the simulation environment is presented which is used for the evaluation of EMCA and comparison with other rendezvous strategies, together with different PR activity traffic models.

5.4.1 Simulator Setup

For CRN simulation, a Cognitive Radio Cognitive Network (CRCN) patch [96] of NS-2 is used with modifications, which is already discussed in Chapter 3. For the overview, it is discussed here briefly. Mainly, it has three functional layers Network, MAC, and Physical. The rendezvous strategies, channel selection decisions, and LBT approach are implemented at the Network Layer. PR activity model for channel-based PR activities, including different traffic patterns, is implemented at the MAC layer, which keeps track of PR traffic, collisions and interference. The Physical layer has information like transmission power, SNR, Propagation model etc. Information at each layer is shared through a common Information sharing Layer. The neighbour table is encapsulated in a packet header at the Network layer and then passed to lower layers.

5.4.2 Simulation Setup

The network area is set as 1000 x 1000 meters. Initially, only 2 nodes are used as a base scenario, to analyze the rendezvous performance between a single pair of nodes. Later, the number of nodes is increased to 10 for rendezvous performance of multiple nodes in a network. The total numbers of channels are considered as 10 and 20, where each node's ACS is a subset of the total number of channels picked randomly as 7 and 14, which are used to show the impact of increasing the number of channels on the rendezvous performance. Two-ray ground model is used as a propagation model. Nodes are considered as static, where each node is only aware of its own starting time. It is assumed that each node is aware of the total number of the nodes in the network for now. This assumption will be revisited in subsequent Chapters.

5.4.3 Primary User Traffic Patterns

The PR activity module discussed in Chapter 3 generates and keeps track of PR activities on each channel i.e., the sequence of ON and OFF periods by PR nodes over a

simulation time. These ON and OFF periods can be modeled as continuous time alternating ON/OFF Markov Renewal Process [83–85]. The ON period means the channel is occupied by a PR and OFF means the channel is not occupied by a PR and free to use by a CR. The rate parameters of the exponential distribution are λ_X and λ_Y which are provided in Table 5.2 as input values. According to these values, the channels follow the ON and OFF periods.

These rate parameter values (λ_X and λ_Y) are provided as an input for PR activity modelling in the simulator, where PR module calculates the probabilities of channel occupancy and availability (P_{ON} and P_{OFF}) at any given time t and channel utilization (U_i , which is time for which the channel i remains occupied), and assigns the PR activity on each channel. These rate values were also measured in [84].

In disasters, the PR traffic remains unknown, and each link can have different traffic patterns with low occupancy or high occupancy. For example, when a disaster occurs near a coastal area the radar bands can be found with ongoing communication, and when it occurs near an urban area than TV or cellular bands can be found with variable occupancies at times. In fact, disasters can occur at any place and time, and depending on the locations the PR occupancy can be different. Therefore, these rate values are adjusted carefully to generate different PR activity traffic patterns, and are shown in Figure 5.7 and Table 5.2, to analyze the performance of rendezvous protocols for different PR activities. These PR activity traffic patterns include,

- Zero PR Activity (0%): The channel is available i.e., idle all the time¹.
- Low PR Activity (10% to 20%): The channel is mostly in idle state and for short time in the busy state. This type of PR activity can be observed in remote areas.
- Long PR Activity (45% to 60%): The channel is in the busy state for a long time and can be idle for long time. This type of PR activity can be seen over TV bands.
- High PR Activity (70% to 85%): The channel is busy for a long time and idle for a short time. This type of PR activity can be seen in urban areas. In urban areas, the population ratio is usually high and when a disaster occurs near an urban area, it is expected that the traffic on existing or survived network's links will be high.
- Intermittent PR Activity (40% to 60%): The channel is in the busy state for a short time and again idle for a short time. This type of PR activity can be ob-

¹For Zero PR activity, λ_X is set as 10000 and λ_Y as 0 with $U_i = 0$.

served where users use the channels for very short period of time, e.g., crowded areas like railway stations or airports.

- **Mix PR Activity:** Different PR activities are randomly assigned to different channels, which are listed above as zero, low, long, high and intermittent. It is the most usual scenario for a disaster, where different bands can have different utilization. For example, a first responder might be using their own network for walkie-talkie based voice communication which can result in partial channel occupancy. A news agency might be using channels for their own transmissions with live video streaming. The partially destroyed cellular base stations might still be in service, providing voice communications on cellular bands. These scenarios provide different channel usage patterns.

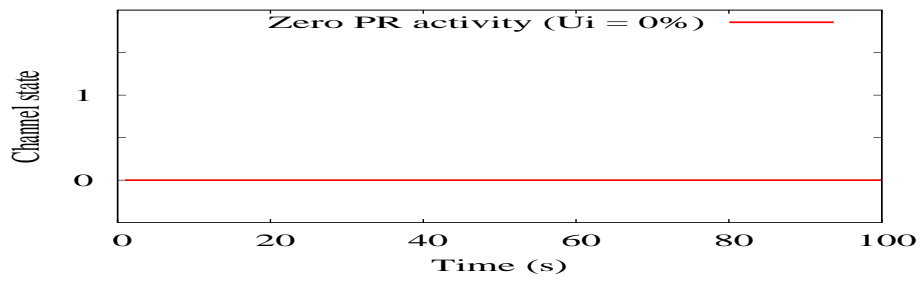

(a) Zero PR Activity

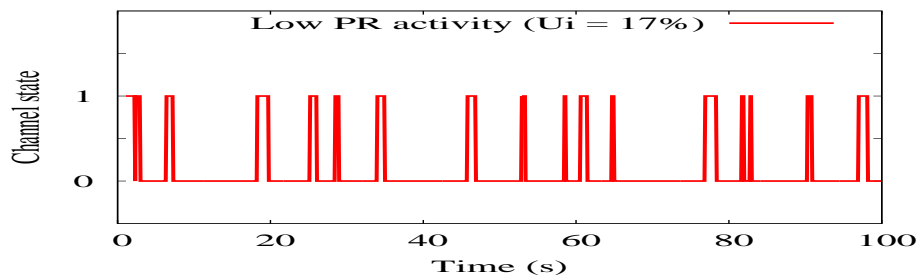

(b) Low PR Activity

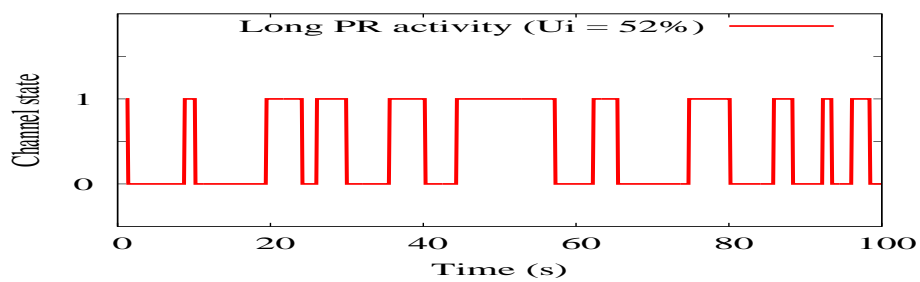

(c) Long PR Activity

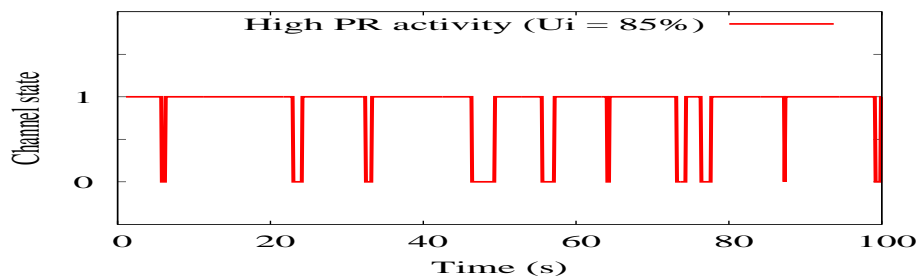

(d) High PR Activity

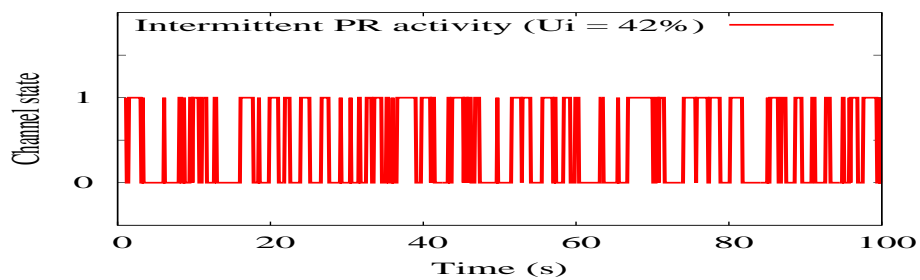

(e) Intermittent PR Activity

Figure 5.7: Different PR activity patterns.

Table 5.2: Rate parameters values for channel states used in the simulations

Channel Id	Low			LONG			HIGH			INTER			MIX		
	λ_X	λ_Y	U_i	λ_X	λ_Y	U_i	λ_X	λ_Y	U_i	λ_X	λ_Y	U_i	λ_X	λ_Y	U_i
1	1.28	0.28	0.18	0.23	0.49	0.68	0.25	0.93	0.79	1.79	1.3	0.42	10000	0	0
2	1	0.33	0.25	0.21	0.32	0.61	0.3	1	0.77	1	1	0.5	1.03	0.3	0.23
3	1.01	0.34	0.25	0.26	0.44	0.63	0.25	1.03	0.8	1.45	1.49	0.51	0.22	0.31	0.58
4	1.67	0.32	0.16	0.41	0.39	0.49	0.23	1.45	0.86	1.64	1.45	0.47	0.22	1.2	0.85
5	1.15	0.33	0.22	0.24	0.39	0.62	0.22	1.10	0.84	1.75	1.10	0.39	1.33	1.2	0.47
6	1.89	0.27	0.12	0.24	0.28	0.54	0.25	0.64	0.72	1.59	1.75	0.53	10000	0	0
7	1.03	0.31	0.23	0.26	0.46	0.64	0.22	1.41	0.87	1.49	1.41	0.49	1.28	0.28	0.18
8	1.14	0.27	0.19	0.43	0.41	0.49	0.23	1.59	0.87	1.25	1.59	0.56	0.23	0.49	0.68
9	1.15	0.5	0.3	0.26	0.3	0.53	0.32	0.64	0.66	1.15	1.79	0.61	0.25	0.93	0.79
10	1.69	0.39	0.19	0.44	0.43	0.49	0.21	1.45	0.87	1.69	1.45	0.46	1.79	1.3	0.42
11	1.82	0.24	0.12	0.22	0.32	0.58	0.26	0.81	0.75	1.54	1.35	0.47	10000	0	0
12	1.25	0.33	0.21	0.27	0.49	0.64	0.24	1.25	0.84	1.43	1.25	0.47	1	0.33	0.25
13	1.59	0.43	0.21	0.27	0.32	0.54	0.23	1.15	0.83	1.59	1.15	0.42	0.21	0.32	0.61
14	1.45	0.27	0.16	0.23	0.46	0.67	0.22	1	0.82	1.27	1	0.44	0.3	1	0.77
15	1.45	0.42	0.23	0.27	0.49	0.64	0.21	1.12	0.84	1.45	1	0.41	1	1	0.5
16	1.33	0.31	0.19	0.24	0.33	0.58	0.27	0.75	0.74	1.82	1.56	0.46	10000	0	0
17	1.39	0.42	0.23	0.27	0.31	0.54	0.23	1.32	0.85	1.23	1.41	0.53	1.01	0.34	0.25
18	1.28	0.41	0.24	0.22	0.38	0.63	0.22	1.2	0.84	1.37	1.2	0.47	0.26	0.44	0.63
19	1.41	0.25	0.15	0.28	0.28	0.5	0.25	0.68	0.73	1.69	1.69	0.5	0.25	1.03	0.8
20	1.82	0.36	0.17	0.24	0.32	0.57	0.22	1.10	0.84	1.54	1.10	0.42	1.45	1.49	0.51

5.4.4 Timeslots structure and multiple beacon transmissions

For multiple beacon transmissions, each timeslot is further divided into equal sub-timeslots, as shown in Figure 5.8, where each beacon can be sent at a randomly selected time within the first half of each sub timeslot. As shown in Figure 5.9, if the last two sub-timeslots of the first node overlap with initial two sub-timeslots of another node then sending a beacon at random times in each of these sub-timeslots, can achieve rendezvous provided both nodes pick the same channel. However, if only a single beacon will be transmitted by the first node at random times and that occurs in the initial sub timeslots only, the rendezvous chance will be missed. A scenario is simulated to compare all rendezvous strategies by sending single and multiple beacons using asymmetric channels and asynchronous timeslots. The results in Figure 5.10 (for zero PR activity), confirm that multiple beacon transmissions per timeslot reduce the TTR compared to single beacon transmission for all rendezvous strategies. The experiments are repeated by increasing the PR activity to High (Figure 5.11) and TTR again decreases for multiple beacon transmissions. The results illustrate that by increasing the number of beacons transmission per timeslot from 1 to 5, an improvement is observed in the average time to rendezvous. Therefore, multiple beacons transmission number as 5 are used for the rest of our simulations. Increasing the number of beacons might reduce the gaps between any two beacons and the time required for transmitting a beacon can be affected with possible collisions between the two node's beacons transmissions.

The nodes starting times are shown in Figure 5.9, where each node starts within a time window of one timeslot. However, due to random starting time, the overlap period between two timeslots of different nodes can vary.

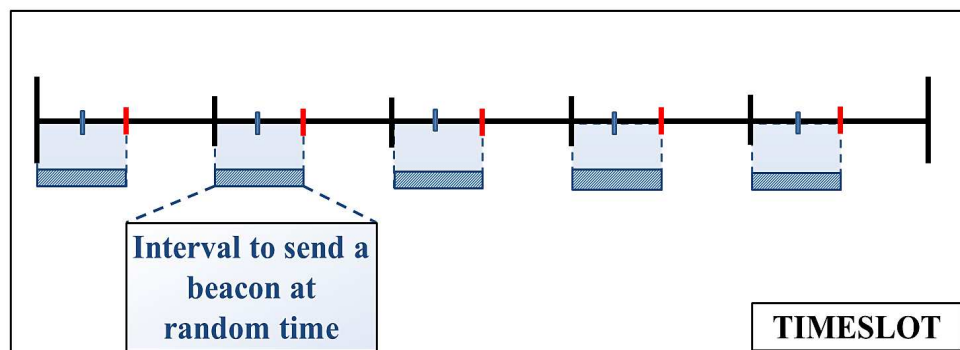

Figure 5.8: Timeslot structure and beacon transmission schedule.

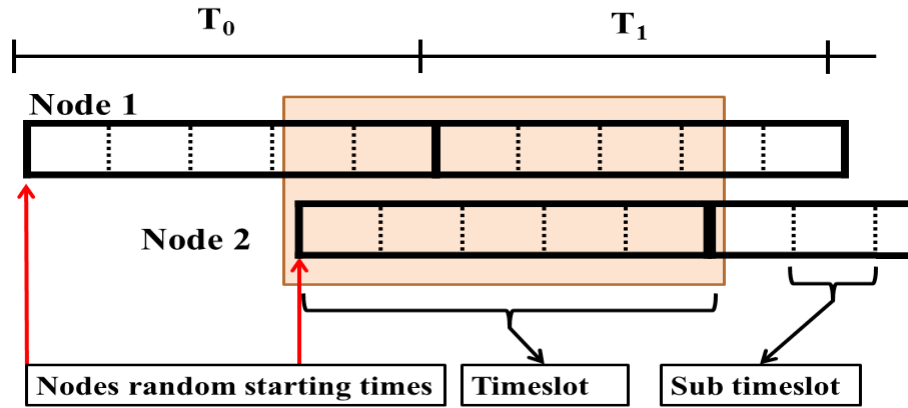

Figure 5.9: Overlapping of timeslots in multiple beacon transmissions.

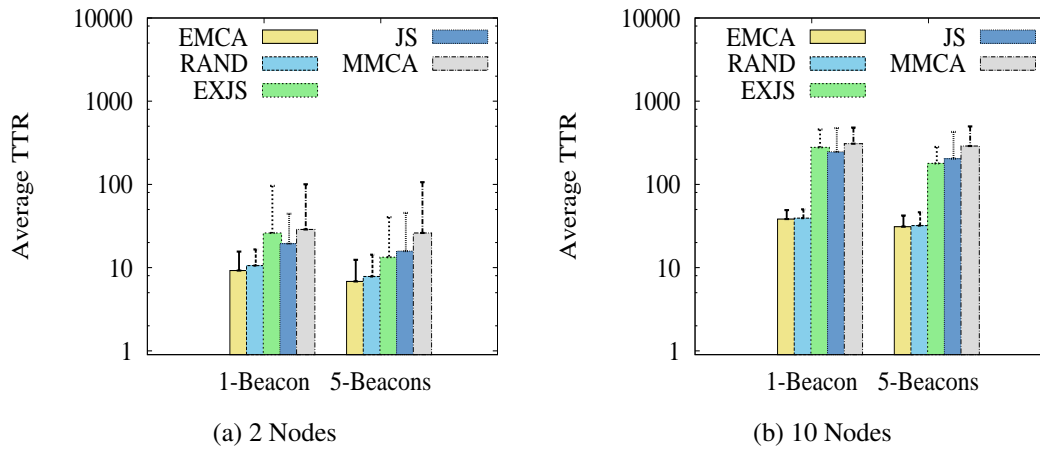

Figure 5.10: Beacons transmission per timeslot comparison under under Zero PR activity and 7 channels.

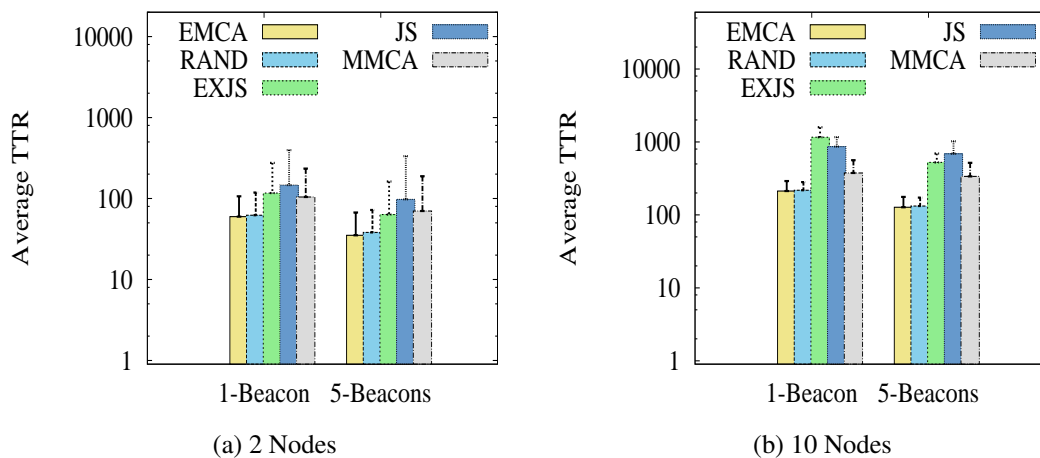

Figure 5.11: Beacons transmission per timeslot comparison under under High PR activity and 7 channels.

5.5 Performance Evaluation

The EMCA is compared with MMCA [40], JS [48], EXJS [48] and a Random strategy. For the sake of fair comparison, the rendezvous cycle length of JS is reduced from $3P$ to $2P$ and named as Extended JS (EXJS). The rendezvous cycle length of JS is $3P$ TSs of which $2P$ is allocated for channel hopping and P for staying on a single channel. Therefore, due to its design, only its hopping period is reduced from $2P$ to P and the staying period is not changed. Each rendezvous strategy is modified to work with the PR activity model (i.e., with LBT). In Random strategy, each node selects a channel in a random manner. Each simulation runs until each node finds every another node in the network. The results shown are an average of 100 simulation runs and are shown in log scale. For channels and timeslots, following cases are considered,

- **Symmetric channels:** In symmetric case, the channels at each node are same.
- **Asymmetric channels:** In asymmetric case, the channels at each node are different, however, the available channels set at each node i is a subset of G .
- **Synchronous timeslots:** In synchronous timeslots case, the nodes are assumed to start at the same times, and therefore their timeslots are aligned with each other.
- **Asynchronous timeslots:** In asynchronous timeslots case, it is assumed that each node starts at a different time within a window of one timeslot. Therefore, their timeslots are not aligned with each other, but, they overlap for certain time duration.

5.5.1 Performance Metrics

The goal is to achieve a rendezvous among all nodes with minimum time to rendezvous and harmful interference. Therefore, EMCA and other blind rendezvous strategies are evaluated over different PR activity patterns, using the following evaluation metrics,

1. **Average Time to Rendezvous (ATTR):** It is used to evaluate the rendezvous delay and measured from the time when the first node starts its rendezvous process to the time when the last node achieves rendezvous with all its neighbours. It is measured in timeslots.
2. **Average Harmful Interference (HI):** The harmful interference can be defined as an interference which endangers, seriously degrades or repeatedly interrupts

the primary radio systems communication. It is used here as a metric to account for the rendezvous performance while considering the primary radio activity. It is measured as the average number of times when interference is caused by a CR towards a PR, which occurs when a CR transmits its beacon while a PR is active.

5.5.2 Symmetric channels case

In the symmetric channels case, all the rendezvous strategies are simulated over both the synchronous and asynchronous timeslots. The results are presented in Figures 5.12 to 5.14, and Table 5.3, for the ATTR and HI. These cases are simulated over zero and high PR activities as an ideal and worst case scenario using 7 and 14 channels. The key observations from these results are:

- The average time to rendezvous for all rendezvous strategies is found to be better when asynchronous timeslots were used. In asynchronous timeslots, the nodes whose timeslots overlap for at least a duration of one sub-timeslots, are actually getting two chances to attempt a rendezvous on two different channels, as can also be seen from Figure 5.9.
- The ATTR of all rendezvous strategies increases with the increase in the number of channels, for both synchronous and asynchronous timeslots. When the number of channels is less, the nodes can focus on fewer channels and therefore the rendezvous chance increases.
- With increase in the PR activity from zero to high, the ATTR increases also, as shown in Figures 5.12 and 5.13. When the PR activity is high, most of the time rendezvous cannot be attempted which abandons the rendezvous guarantee and therefore the ATTR is higher, which increases more with the increase in the number of channels.
- EMCA is found to be better than all rendezvous strategies in terms of ATTR, due to its shorter rendezvous cycle length. However, Random is found to be with highest ATTR in comparison with all algorithms (for zero PR activity). It also increases more with increases in the number of channels which is due to its probability of rendezvous success decreases with increase in the number of channels (identical), as also shown in [40]. JS is shown to be only marginally slower than MCA. However, when the PR activity is increased to 85% (i.e., High PR activity), even though the ATTR increases, EMCA appears as better than all other strategies (Figure 5.13).

- The average HI is shown in Figure 5.14 for both synchronous and asynchronous scenarios. For Zero PR case, due to the absence of PR, no HI is observed, as shown in Table 5.3. A drop in the HI is observed from the synchronous to the asynchronous case, due to their lower TTR values. However, overall the harmful interference incidents were observed below 0.11, as can be seen in Table 5.3.

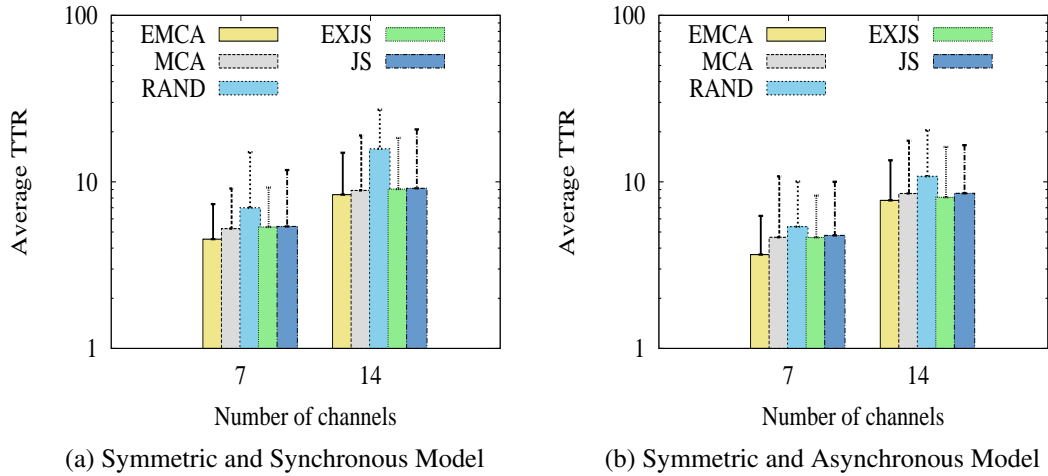

Figure 5.12: Average TTR for 2 nodes under zero PR activity

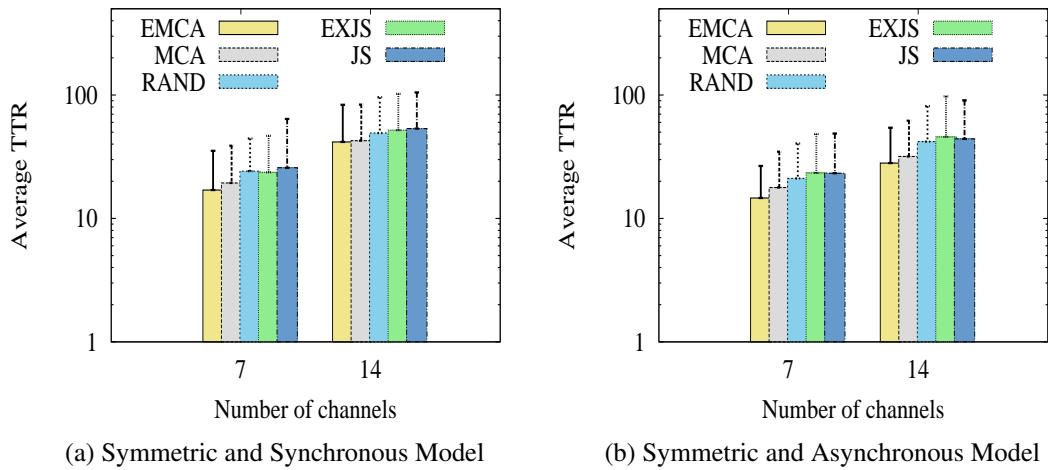

Figure 5.13: Average TTR for 2 nodes under high PR activity

Overall, EMCA appear as better in terms of ATTR in comparison with other rendezvous strategies, while also considering the PR activity. Asynchronous timeslots case is shown to be more beneficial than the synchronous timeslots case. From here on, the focus will be on the asymmetric channels case with asynchronous timeslots, which is a more realistic assumption. In disaster environments, the available channels are expected to vary from node to node due to the spatial diversity of channels and

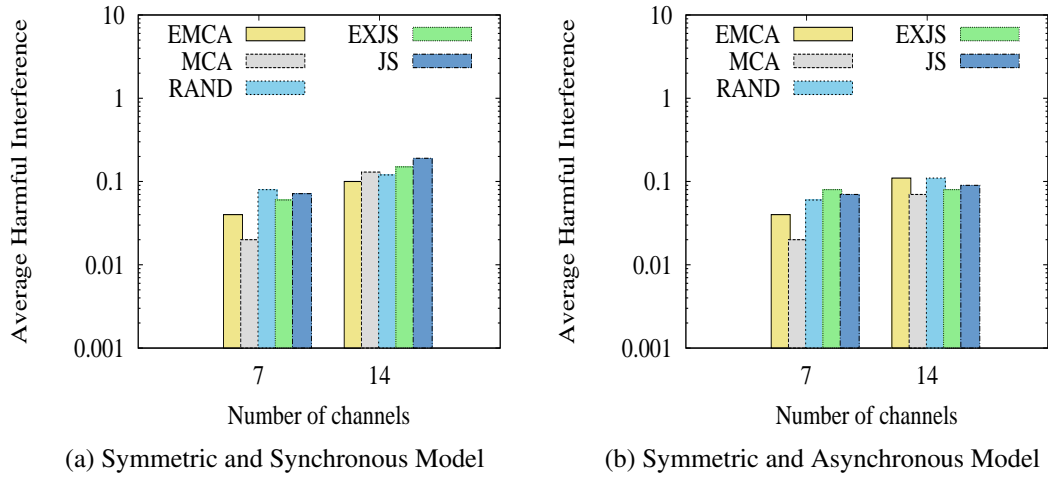

Figure 5.14: Average Harmful Interference for 2 nodes (High PR activity)

Table 5.3: ATTR and HI for 2 nodes with symmetric channels, synchronous and asynchronous timeslots.

		Rend proto- col	7 channels		14 channels	
			Zero PR activity	High PR activity	Zero PR activity	High PR activity
ATTR	Synch TS	EMCA	4.53	17	8.38	41.68
		MCA	5.24	19.39	8.89	42.66
		RAND	7	24.18	15.81	49.28
		EXJS	5.36	23.65	9.05	51.98
		JS	5.4	25.75	9.15	53.47
	Asynch TS	EMCA	3.66	14.65	7.74	28.1
		MCA	4.65	17.8	8.52	31.78
		RAND	5.39	21.1	10.81	41.92
		EXJS	4.64	23.38	8.08	45.77
		JS	4.77	23.27	8.54	44.14
HI	Synch TS	EMCA	0.00	0.04	0.00	0.1
		MCA	0.00	0.02	0.00	0.13
		RAND	0.00	0.08	0.00	0.12
		EXJS	0.00	0.06	0.00	0.15
		JS	0.00	0.07	0.00	0.19
	Asynch TS	EMCA	0.00	0.04	0.00	0.11
		MCA	0.00	0.02	0.00	0.07
		RAND	0.00	0.06	0.00	0.11
		EXJS	0.00	0.08	0.00	0.08
		JS	0.00	0.07	0.00	0.09

distance of cognitive radios to the localized primary radios in that particular region.

5.5.3 Asymmetric channels case

In this section, the asymmetric channels are used to compare and analyse EMCA with other rendezvous strategies. Different PR activities, as discussed previously in Section 5.4.3, are used for analysis.

5.5.3.1 Average time to rendezvous

The results for average time to rendezvous, are shown in Figures 5.15 to 5.20 and Table 5.4, for 2 and 10 nodes, and over different PR activity traffic patterns. The percentage improvement of EMCA over other blind rendezvous protocols is shown in Table 5.5. The key observations are,

- The average time to rendezvous increases with increase in the number of channels and nodes in all cases.
- With increase in the PR activity from zero to High, the ATTR increases as well. The highest ATTR is observed when PR activity was high, as shown in Figure 5.18, for all rendezvous protocols.
- EMCA outperforms the existing rendezvous strategies under all PR activity traffic patterns, as shown in Figures 5.15 to 5.20. However, in comparison with Random strategy, it is only marginally better. The existing strategies like MMCA, JS, and EXJS are much slower in terms of average TTR, due to their long rendezvous cycles, as can also be observed from Table 5.4.
- EXJS, which is a variation of JS algorithm, appears as better than JS and MMCA, due to its reduced rendezvous cycle length (i.e., $2P$).
- For high PR activity case, EMCA and Random outperforms all the existing blind rendezvous strategies. In comparison with EMCA, Random is only marginally worse, as shown in Figure 5.18. However, MMCA and JS appear as worse in all cases.
- The improvement of EMCA (under High PR activity and 7 channels) is observed as 64% over JS and 49.96% over MMCA, for 2 nodes case. For 10 nodes, it increases to 81.47% over JS, 62.20% over MMCA, and over Random strategy,

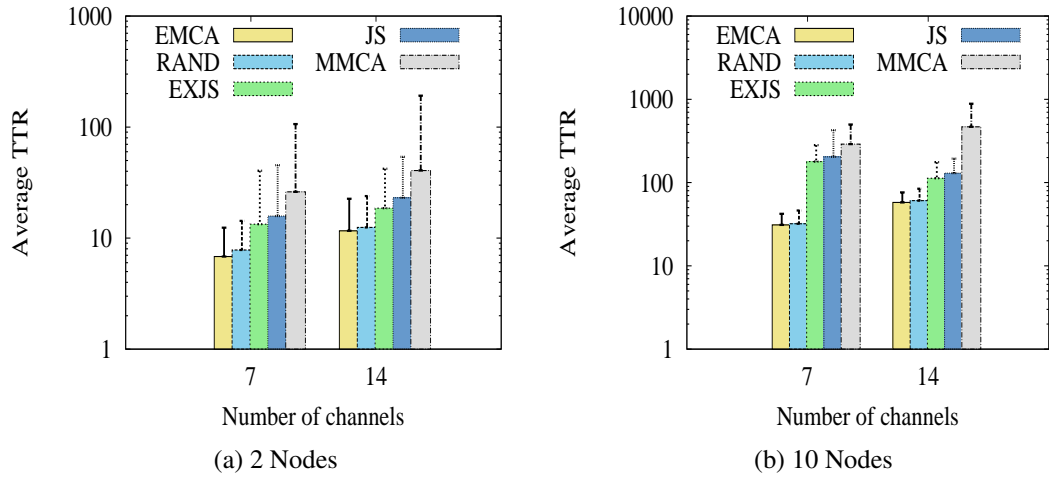

Figure 5.15: Average time to rendezvous under Zero PR activity.

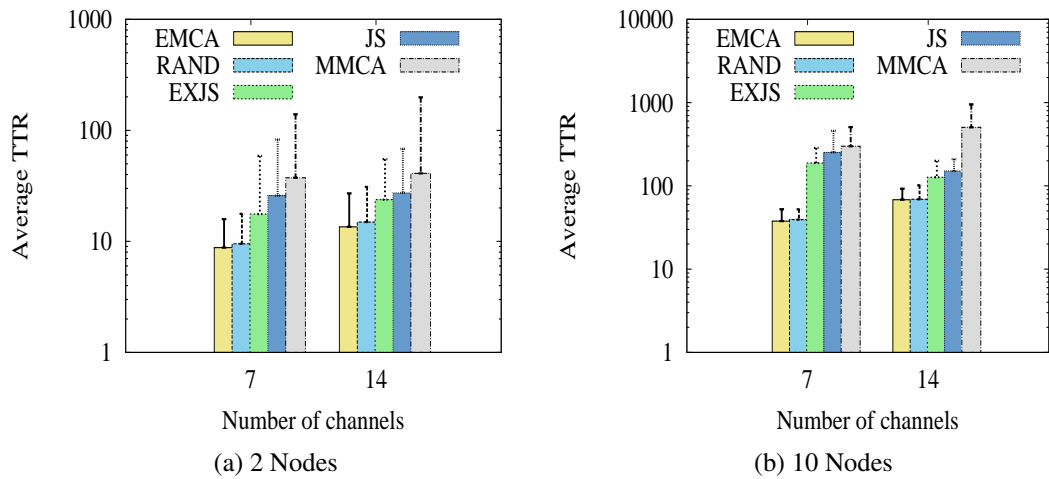

Figure 5.16: Average time to rendezvous under Low PR activity.

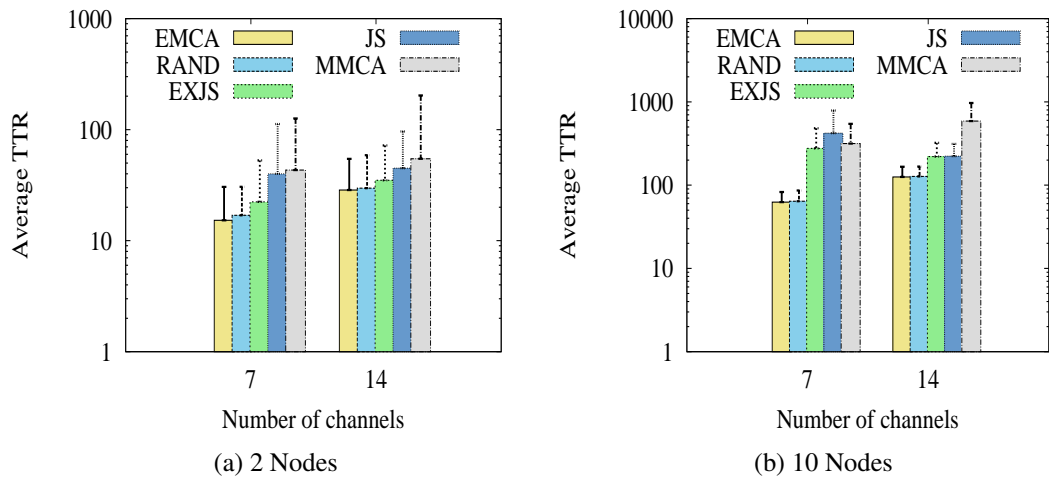

Figure 5.17: Average time to rendezvous under Long PR activity.

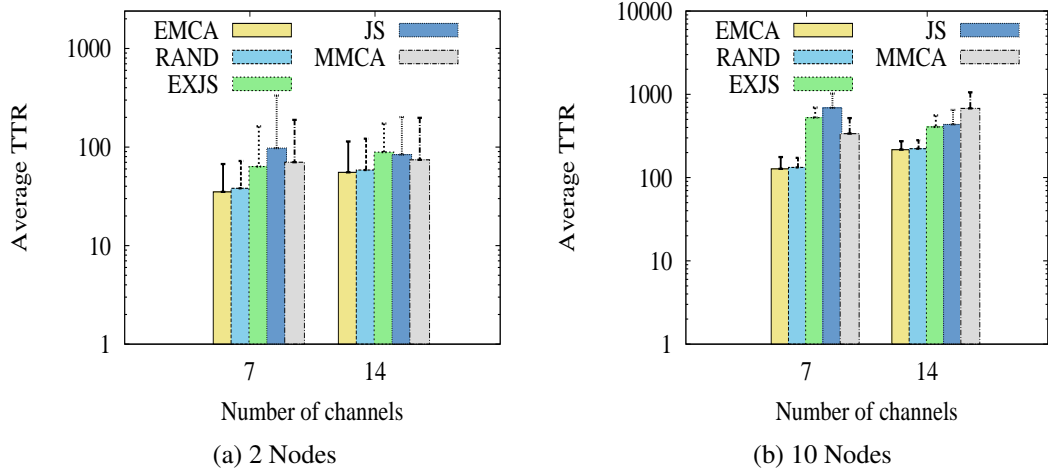

Figure 5.18: Average time to rendezvous under High PR activity.

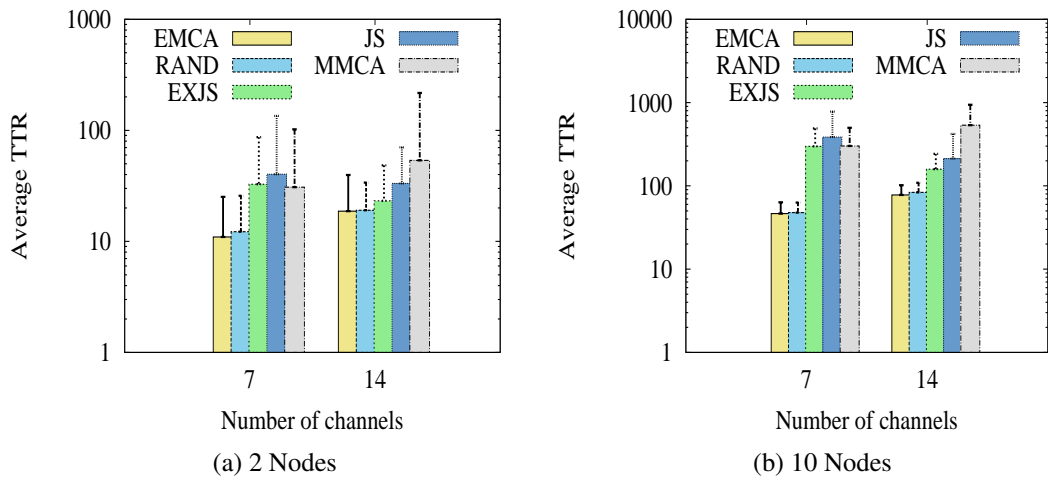

Figure 5.19: Average time to rendezvous under Intermittent PR activity.

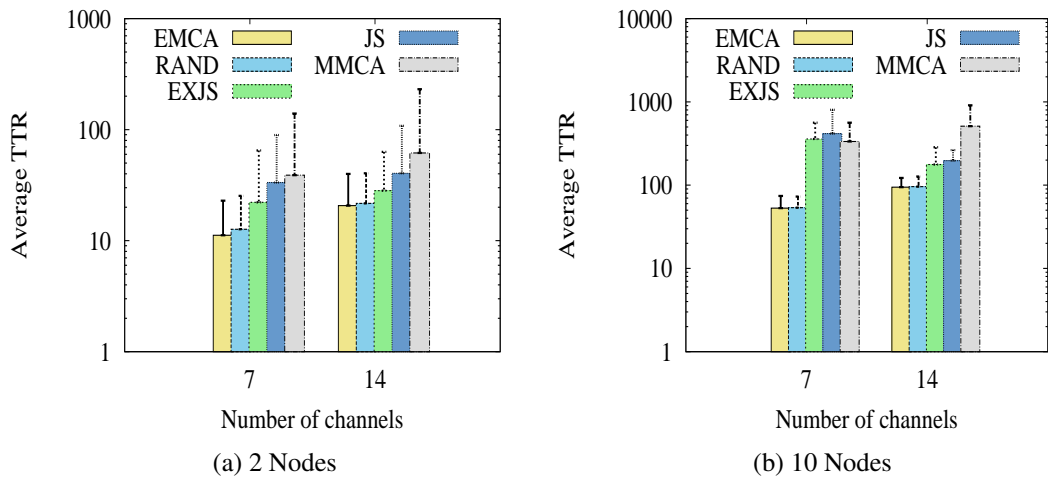

Figure 5.20: Average time to rendezvous under Mix PR activity.

it is observed as 3% for 2 nodes and 8% for 10 nodes. These improvement percentages are shown in Table 5.5.

- For Mixed PR activities, as shown in Figure 5.20, the ATTR decreases more than in High PR activity case, which is due to random selection of channels with lower or zero PR activities, which gives more clear opportunities to a node to attempt a rendezvous by sending a beacon.

Overall, the average time to rendezvous increases with increases in the number of channels, nodes and the PR activity. EMCA and Random appear as better than all the other blind rendezvous strategies, in terms of the ATTR. However, the Random is shown to be only marginally worst than EMCA. In symmetric channels case, EMCA is found to be better than Random, however, in asymmetric channels case, EMCA is found to be better than Random on average. Highest ATTR was observed when PR activity was high and 10 nodes were used.

5.5.3.2 Average harmful interference

In Figures 5.21 to 5.25, the average number of incidents of harmful interference are shown (i.e. when CR transmissions coincide with PR activity) in the same experiments as for Figures 5.16 to 5.20. The results for harmful interference are also shown in Table 5.4. There is obviously no harmful interference in the zero PR activity case, and so the graphs are omitted. The key observations are,

- The average harmful interference increases with increases in the number of channels, nodes and PR activity.
- For 2 nodes, the HI observed as relatively low with mostly less than 4 incidents in 100 simulation runs overall, for all rendezvous strategies under Low and Long PR activities, as shown in Figures 5.21 and 5.22. However, for MMCA it appears as 0.16. These HI incidents can also be observed from Table 5.4.
- With increase in PR activity to High, the HI increases to 0.1 for EMCA i.e., (1 incident in every 10 simulation runs) and up to 0.26 for JS and MMCA (Figure 5.23).
- The highest number of HI incidents are observed for Intermittent PR activity case (Figure 5.24), in which the JS and MMCA are appeared with 0.4 incidents every 10^{th} run on average.

Table 5.4: ATTR and HI for asymmetric channels and asynchronous timeslots.

	No, of nodes	Rend proto-col	7 channels					14 channels						
			ZERO	LOW	LONG	HIGH	INTER	MIXPR	ZERO	LOW	LONG	HIGH	INTER	MIXPR
ATTR	2 nodes	EMCA	6.82	8.79	15.25	35.09	10.96	11.19	11.62	13.51	28.58	55.36	18.71	20.69
		RAND	7.82	9.51	16.94	38.16	12.22	12.67	12.47	14.94	29.71	58.42	19.06	21.68
		JS	15.80	25.84	40.03	97.68	40.32	33.39	23.09	27.33	44.96	83.81	33.28	40.43
		MMCA	26.09	37.42	43.23	70.12	30.77	38.87	40.57	41.01	54.66	74.21	53.60	61.61
		EXJS	13.35	17.63	22.38	63.48	32.74	22.15	18.60	23.80	34.99	88.93	23.23	28.22
	10 nodes	EMCA	31.04	37.73	62.49	127.40	46.42	53.03	57.77	68.16	125.35	216.32	77.68	94.57
		RAND	32.01	39.39	64.17	132.39	47.77	53.58	60.68	69.06	127.24	222.39	83.62	96.05
		JS	203.65	252.48	421.37	687.41	386.01	415.42	129.77	150.91	223.01	435.24	212.33	196.72
		MMCA	289.60	298.90	316.23	337.05	301.45	334.19	467.49	504.49	587.76	676.91	535.01	510.53
		EXJS	178.75	188.17	276.70	524.78	298.35	358.61	112.84	127.07	220.41	405.79	158.67	177.16
HI	2 nodes	EMCA	0.00	0.03	0.04	0.10	0.11	0.05	0.00	0.04	0.06	0.14	0.18	0.09
		RAND	0.00	0.02	0.03	0.06	0.07	0.05	0.00	0.01	0.08	0.12	0.20	0.05
		JS	0.00	0.04	0.08	0.26	0.39	0.06	0.00	0.10	0.10	0.31	0.26	0.08
		MMCA	0.00	0.14	0.16	0.20	0.32	0.15	0.00	0.14	0.07	0.15	0.46	0.18
		EXJS	0.00	0.04	0.05	0.16	0.23	0.04	0.00	0.07	0.04	0.11	0.24	0.09
	10 nodes	EMCA	0.00	0.65	0.57	1.59	2.28	0.84	0.00	1.05	1.25	2.50	2.80	1.39
		RAND	0.00	0.70	0.60	1.65	2.06	0.69	0.00	1.11	1.14	2.40	3.17	1.45
		JS	0.00	3.82	4.24	7.87	16.47	6.25	0.00	2.57	1.99	5.03	9.03	3.09
		MMCA	0.00	4.27	3.51	4.04	13.08	4.51	0.00	7.67	5.77	7.99	20.93	7.49
		EXJS	0.00	2.95	4.17	5.40	12.85	5.53	0.00	2.20	1.86	4.22	6.87	2.66

- With an increase in the number of nodes to 10, the EMCA and Random strategies manage to remain below 1 incident on average (Figure 5.21b), under low PR activity. However, when PR activity was high, the HI is observed as not an ignorable quantity with 1.6 incidents in every simulation run on average for EMCA and Random, and 7.8 incidents for JS, as shown in Figure 5.23b, which is due to the high values of TTR.
- Under the intermittent PR activity pattern (Figure 5.24b), the HI further increased to up to 2 incidents on average for EMCA and Random; and up to 16 and 13 incidents for JS and MMCA, which is due to the irregular and frequent PR arrivals on particular channels.

Table 5.5: Percentage improvement of EMCA over other rendezvous protocols in terms of TTR (asymmetric channels case).

			PR activity					
Node	Chan		ZERO	LOW	LONG	HIGH	INTER	MIX
2	7	RAND	12.79	7.57	9.98	8.05	10.31	11.68
		JS	56.83	65.98	61.90	64.08	72.82	66.49
		MMCA	73.86	76.51	64.72	49.96	64.38	71.21
		EXJS	48.91	50.14	31.85	44.73	66.52	49.49
	14	RAND	6.82	9.57	3.80	5.24	1.84	4.57
		JS	49.68	50.57	36.43	33.95	43.78	48.83
		MMCA	71.36	67.06	47.71	25.40	65.09	66.42
		EXJS	37.53	43.24	18.32	37.75	19.46	26.68
10	7	RAND	3.03	4.21	2.62	3.77	2.83	1.03
		JS	84.76	85.06	85.17	81.47	87.97	87.23
		MMCA	89.28	87.38	80.24	62.20	84.60	84.13
		EXJS	82.63	79.95	77.42	75.72	84.44	85.21
	14	RAND	4.80	1.30	1.49	2.73	7.10	1.54
		JS	55.48	54.83	43.79	50.30	63.42	51.93
		MMCA	87.64	86.49	78.67	68.04	85.48	81.48
		EXJS	48.80	46.36	43.13	46.69	51.04	46.62

Overall, with an increase in the number of nodes from 2 to 10 approximately an order of magnitude increase is observed in the harmful interference. EMCA outperforms the existing rendezvous strategies in terms of the average TTR, however found to be

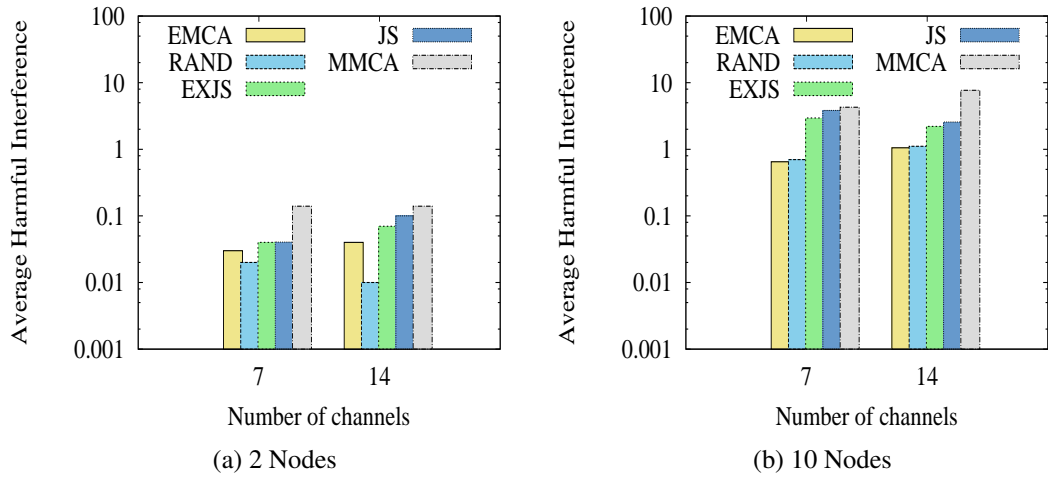

Figure 5.21: Average Harmful Interference under Low PR activity.

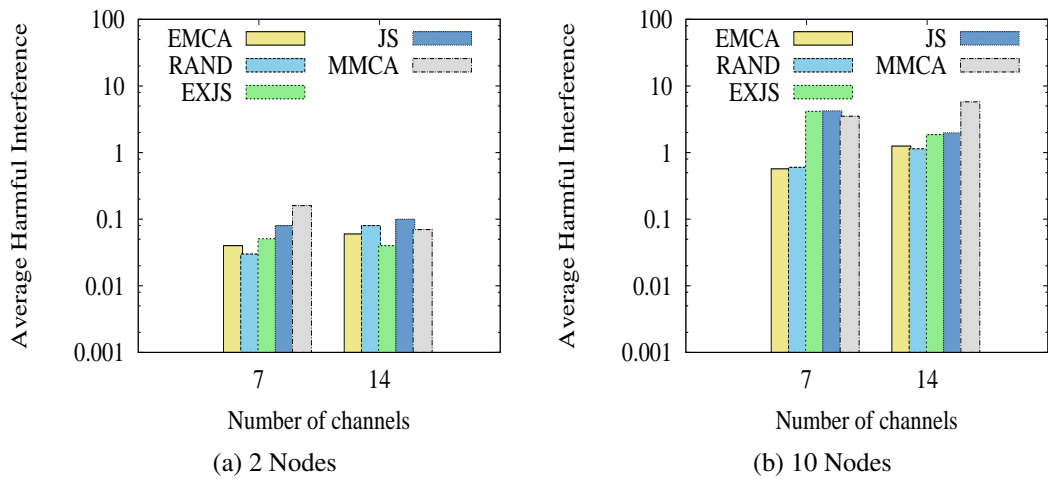

Figure 5.22: Average Harmful Interference under Long PR activity.

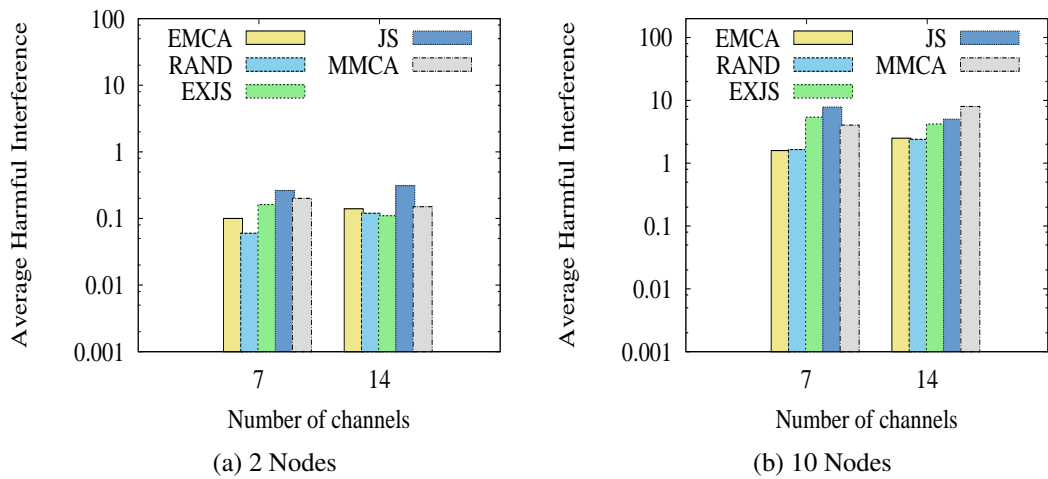

Figure 5.23: Average Harmful Interference under High PR activity.

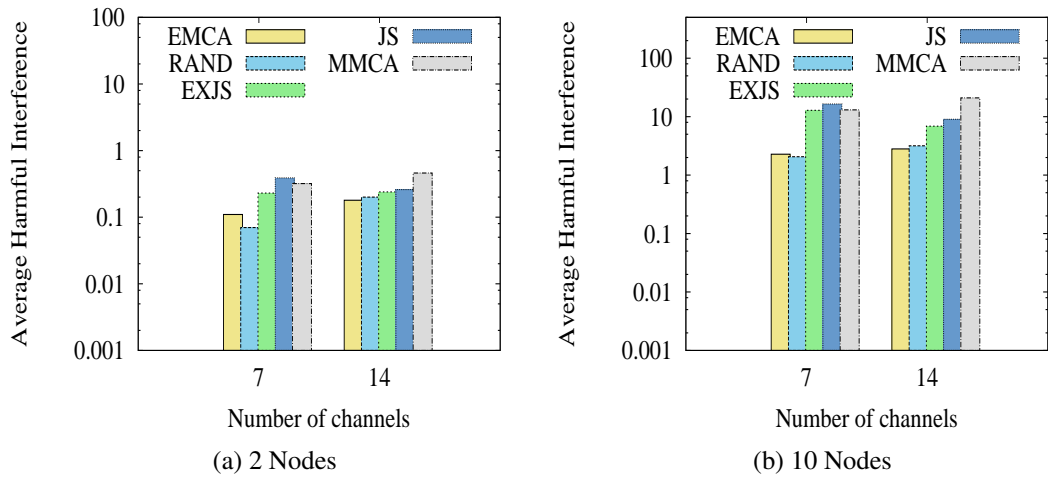

Figure 5.24: Average Harmful Interference under Intermittent PR activity.

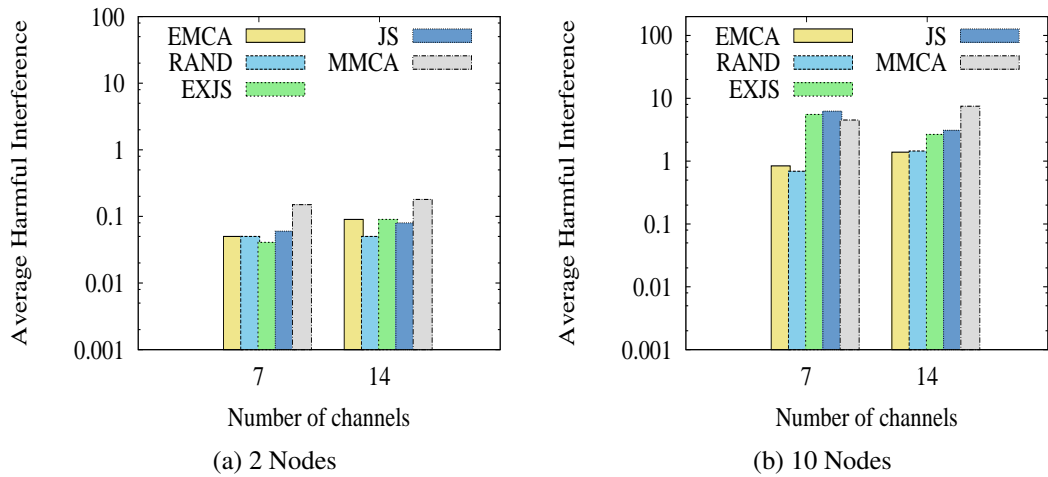

Figure 5.25: Average Harmful Interference under Mix PR activity.

only only marginally better than Random strategy. For harmful interference, EMCA and Random appeared as less interfering with PR in comparison with MMCA, JS, and EXJS. However, the harmful interference is observed as considerably higher for all rendezvous strategies, especially for 10 nodes.

5.6 Chapter conclusion

It is widely acknowledged that the flexibility of cognitive radio networks makes them especially suitable for operation in unknown environments, such as disaster response. Blind rendezvous is essential in such situations, but existing techniques make assump-

tions about primary radio activity and the radio environment. In order to overcome these restrictive assumptions, this chapter presented an Extended Modular Clock blind rendezvous protocol, which is intended to reduce the network setup delay in a disaster situation. Experiments with a variety of primary radio traffic models show up to 89% improvement in the key metric time to rendezvous over the existing blind rendezvous strategies. Reductions in the effect of harmful interference in comparison with the existing rendezvous strategies is also observed empirically. However, the harmful interference is observed as fairly high with increasing number of nodes.

Chapter 6

Cognitive Radio Policy based Adaptive Blind Rendezvous Protocols

6.1 Introduction

A policy is a set of rules which governs the behavior of the system and describes what should be done in a particular situation. It determines a plan to influence the decision or next action to be taken. From a cognitive radio perspective, spectrum policies are the rules that specify in what frequency bands the radio is permitted or prohibited to transmit, when the particular spectrum can be used, for how long and under what conditions it can be used. As cognitive radios are mainly designed to operate on licensed bands in an opportunistic manner. These policies mainly set the rules to allow the CR operation while protecting the primary radio systems. In a situation of sudden change in the spectrum availability, these policies direct the next action, which could be to prohibit further transmission on that channel, to select the next appropriate channel which satisfies the communication requirements and to monitor the allowed interference threshold.

The spectrum usage policies can be established by regulators, standard bodies, manufacturers or system operators before the deployment, or can be made standalone to operate on its own based on radio environment learning. These policies are defined mainly in the standards. The current standards for the deployment and operation of a CR system were discussed in Chapter 3. These promote the usage of spectrum databases for spectrum access information. However, in the event of a disaster these databases might not be available and therefore a cognitive radio has to rely on its sensing to identify, vacate and avoid the channels on which PR is detected. Further, to

reduce the harmful interference, these standards also suggest some parameters including the channel non-occupancy period and channel availability check time, to make sure that primary radio is not active on a particular channel. Therefore, these policies encourage the efficient use of channels for cognitive radio network operation.

The standard bodies encourage the use of policy-based radios [6, 73]. However, the impact of CR operating policies on the blind rendezvous performance is still unknown. The blind rendezvous strategies which consider the PR activity, do not consider the amount of harmful interference caused towards the PR system. Whereas, the standard bodies like IEEE, only permits the usage of CR, when it operates without causing harmful interference towards the PR system. Even in the situations, like disasters, there could be existing survived cellular services, which might be providing services over the cellular bands, and operating over those bands can interfere with their ongoing voice communication. Therefore, an efficient blind rendezvous strategy must consider the PR activity, and also should not create harmful interference towards the PR systems.

The basic policy used so far in the literature and in the previous chapter (Chapter 5), is the LBT approach, which listens for the PR activity before every transmission, and only avoids transmission when PR is detected on that channel. The LBT approach, waste time by staying silent on a channel when PR is detected, and also probes on that channel repeatedly, which results in excessive harmful interference and increased rendezvous delay. However, to protect a PR from harmful interference, it must avoid that channel for some time and also utilize the wasted time efficiently by using an alternate channel to at least attempt a rendezvous.

In this chapter, different CR operating policies are proposed. These can work with any rendezvous strategy. It is shown that these policies can achieve the design goals of protecting the primary radios from harmful interference and also can reduce the rendezvous delay with adaptiveness towards the unknown primary radio activity to achieve the performance goals. These policies are compared with the basic LBT policy (also presented in previous chapter 5).

6.1.1 Main contributions

The main contributions of this chapter are:

1. Different CR operating policies which adapt to PR activities to reduce harmful interference towards the primary radio and the time to rendezvous in an unknown environment. These proposed policies are:

- Normal, which blacklists channels on which a PR is detected.
 - Reactive, which reactively searches for a free channel if the current channel is detected with PR activity.
 - Proactive, which learns the channel occupancy behavior and provides the best channel in terms of its availability.
2. The effectiveness of proposed operating policies is demonstrated over different primary radio activity patterns, for different blind rendezvous algorithms.

6.2 Cognitive radio operating policies

In this section, different proposed cognitive radio operating policies are presented in the order of their improvement over the LBT approach. These policies are mainly to protect a primary radio system and to decide the next course of action when a primary radio is detected on a channel. These policies are mainly a part of the radio operation and can assist any rendezvous protocol to decide the next action based on the detected channel condition to handle the unknown PR activity together with the rendezvous process.

The blind rendezvous algorithms are mainly designed to select channels in a systematic way to increase the chance of a successful rendezvous. However, on detection of a primary user activity, these rendezvous algorithms cannot handle the situation alone. However, they can be integrated with the radio operating policies, which can assist them in deciding the next course of action. In a simple way, an LBT can be used, which can decide to send a beacon or not, based on the PR activity appearance on a channel. However, it has its own drawbacks,

- It violates the recommendations of the standard bodies by continuing to probe on a channel already detected with a PR activity.
- By not attempting a rendezvous (i.e., not to send a beacon), it wastes time which can increase the network setup delay.
- By continuously attempting on a channel detected with PR activity, it can cause excessive harmful interference, which is not encouraged at all by the standard bodies and service providers.

Therefore, different operating policies are proposed based on the improvements over an LBT approach. When a CR selects a channel using a rendezvous algorithm, then

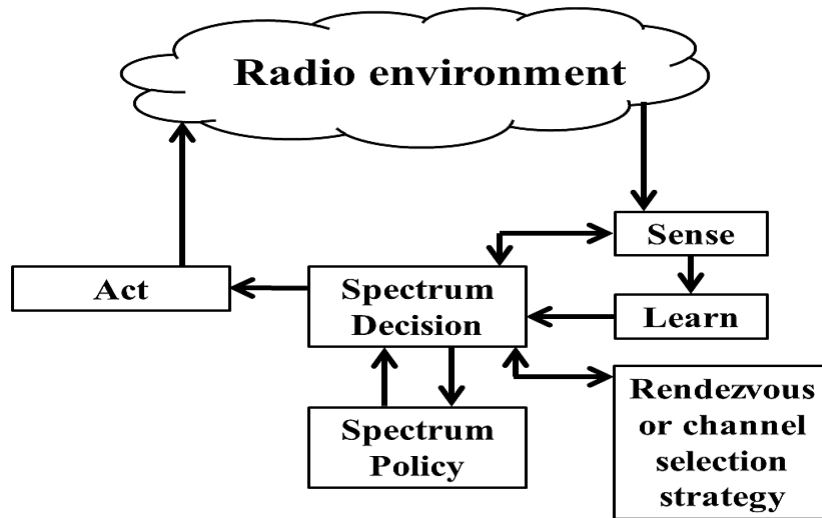

Figure 6.1: Functional blocks for spectrum decision and policy.

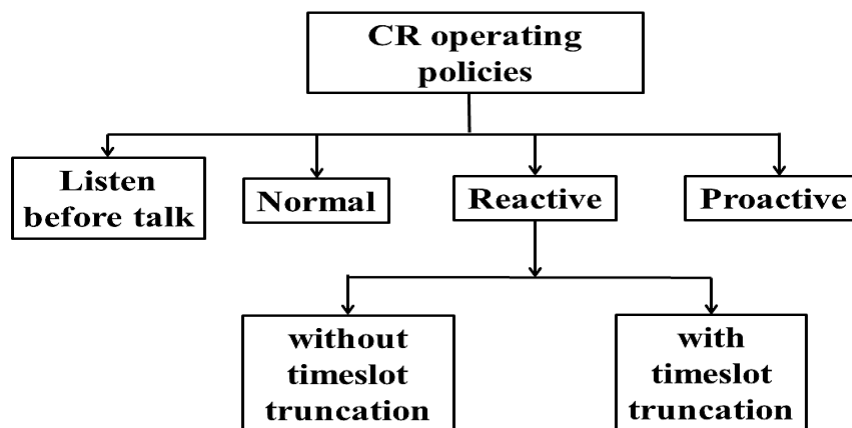

Figure 6.2: Classification of CR operating policies.

initially this channel will be sensed for the primary user presence. Based on the channel condition, a CR node can decide to select a new channel by running a rendezvous algorithm and to get assistance from the spectrum policy block, when a channel is detected with PR activity, as shown in Figure 6.1. A spectrum policy block, which keeps track of channels, can decide to either blacklist a channel if the current channel is detected with PR activity or to permit its usage if the channel is not currently occupied and not blacklisted. These restrictions are described in [6] as channel availability check (CAC) and channel non-occupancy period (CNP). CAC is the time during which a channel should be checked for the presence of a PR. CNP is the period during which

a CR should avoid transmission on a channel which is already detected as occupied. Each node maintains its blacklisted channels list (BLC) for spectrum policy decisions, in which channels detected with PR activity will remain until their CNP time expires, then only they can be used. Further policy conditions can also be introduced in a spectrum policy block, like channel usage based on the transmission power or allowed interference threshold. A CR can also learn to assist the spectrum policy decision in parallel with spectrum sensing. These policies are explained below in a general way and can be integrated with any blind rendezvous approach to perform a rendezvous task in an efficient way. These proposed policies are also classified in Figure 6.2.

6.2.1 Normal Policy

Different from the LBT approach, in Normal policy the node will not only stop its communication on the PR detected channel but also blacklist the channel, to follow the CR specifications. The Normal policy is the distributed version of 802.22, however in 802.22 with channel blacklisting the next channel is selected by using a spectrum database but in the Normal policy the node will remain silent for the duration of a timeslot and also blacklist the channel on which a PR is detected. Figure 6.3, shows the working flow of a Normal operating policy and its behavior when a PR is detected on a particular channel in a timeslot. The specific operation related with Normal policy are shown with red color lines in Figure 6.3. At the start of a timeslot, the node will select a channel using a particular rendezvous algorithm, and the selected channel will be checked for the PR activity and its presence in the BLC list. If the selected channel will be in the BLC list, the node will remain silent for the rest of the timeslot (i.e., it will not transmit any beacon). If it will not be in the BLC list, then only the channel could be sensed for the possible PR appearance. However, if detected with PR activity, then the channel will be added to the BLC list and the node will remain silent for the rest of the timeslot. If the channel is neither in the BLC list nor occupied, then only beacons can be transmitted on their random scheduled times. Unlike in LBT approach, if at any level during a beacon transmission phase, the channel is detected with PR, then it will be added in the BLC and node will remain silent for the rest of the timeslot. The channel will remain in the BLC list until its CNP expires. The channel will be checked for possible PR appearance before every beacon transmission. The new channel will be selected at the start of the next timeslot. In every timeslot, selecting a channel or changing the algorithm related parameters is handled separately by the rendezvous algorithm, and the operating policies will assist the rendezvous algorithms in a way to protect the primary user's communication.

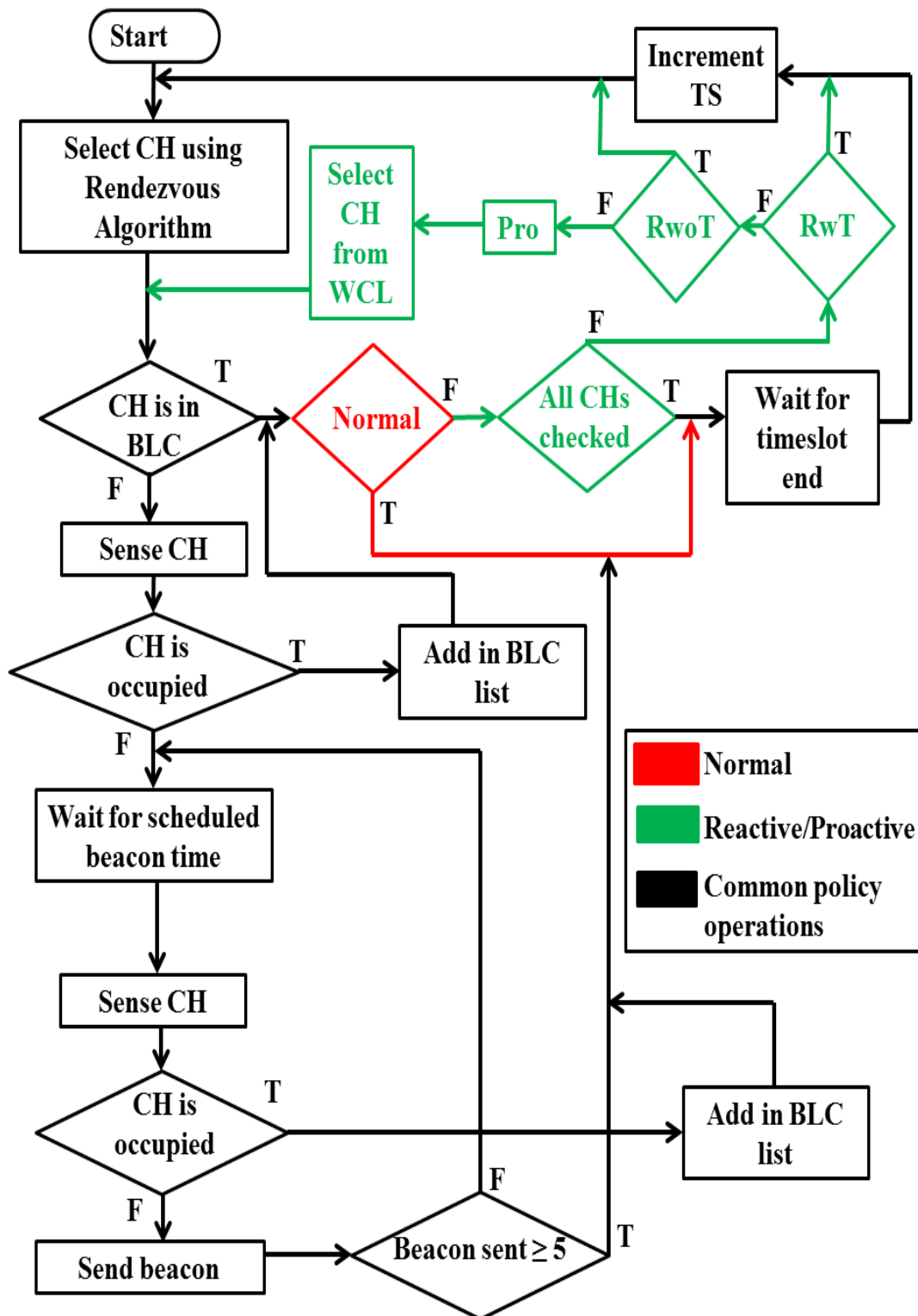

Figure 6.3: Normal, Reactive and Proactive operating policies flowchart.

6.2.2 Reactive Policy

The Normal policy wastes time by staying silent on the current channel, if detected with PR activity. To avoid this, the Reactive policy immediately continues hopping through the channels using its existing rendezvous algorithm. The CR operating limitations are as before, where LBT is followed with CAC/CNP checks. There are two variations, depending on whether or not the timeslot is truncated on PR activity detection at the beginning of the timeslot. Maintaining the timeslot structure keeps any time synchronisation between nodes, while starting a new timeslot means that a node will reach the P timeslots limit faster (in real time), and so if needed can change its rate more quickly. The working flow of Reactive policies are shown in Figure 6.3 and the specific operations related with Reactive policies are shown in green color.

6.2.2.1 Reactive Policy without Timeslot Truncation (RwoT)

In RwoT policy, the node will reactively search for a free channel until one is found or all channels are examined. The RwoT is close to the 802.22 in selecting the next channel immediately, however the difference is that in 802.22 the channel is selected by using a spectrum database whereas in RwoT the node will select a free channel using an independent channel sensing. The working flow of RwoT is shown in Figure 6.3 with green color. Initially, the node will select a channel using a particular rendezvous algorithm and then check for its presence in the BLC or PR appearance on that channel. If occupied by a PR or found in BLC, the next channel will be selected using the existing rendezvous algorithm. The process will continue until a free channel is found or all channels are examined. If a free channel is found, then the node will start its beacon transmission phase. Otherwise, the node will remain quiet until the end of the timeslot. At any instance, during a beacon transmission phase, if a PR is detected while sensing a channel before a beacon transmission, then the channel will be added in the BLC list and the node will stay silent on that channel until the end of a particular timeslot. The next channel will be selected again in a new timeslot and the process of reactively searching for a free channel will repeat again in the next timeslot. The rendezvous algorithm channel selection parameter such as index calculation, in case of EMCA, MMCA, and JS, will be updated every time when a node uses the rendezvous algorithm for a channel selection. However, their rate values (the channel hopping factor) will be updated only when a node completes its rendezvous cycle full length (for example, P timeslots in case of EMCA).

6.2.2.2 Reactive Policy with Timeslot Truncation (RwT)

The RwT policy is shown in Figure 6.3 with green color. In RwT, the node searches for the free channel in a reactive manner as in RwoT. However, with every channel selection, the timeslot number will also increase. By doing this, not only will the node truncate the current timeslot and start the new timeslot for the new channel, but will also reach the P limit faster to select the new rate value (channel hopping factor). The working process of RwT is similar to RwoT policy (Figure 6.3, but with every channel selection the timeslot value also increases).

6.2.3 Proactive Policy

The Proactive policy attempts to learn the behavior of the primary users, going beyond the use of the blacklist. For each channel, it maintains a channel weight C_w^i , which approximates the channel's probability of being unoccupied (or OFF), as shown in Eqn 6.1. The proactive policy is shown in Figure 6.3 and the specific operations related with proactive policy are shown with green color. The policy starts by selecting a channel in each timeslot as normal, using a rendezvous algorithm. However, if the channel is occupied or exists in BLC then the Weighted Channels list (WCL) will be used to pick another channel in proportion to the weights in the WCL. The intention is to augment an existing channel selection algorithm by temporarily returning to channels most likely to be free, rather than staying silent during a slot when PR activity is detected. Besides, the channel selection, it follows the same process for the beacon transmissions as in the reactive policy, where LBT was followed with CNP/CAC checks. At any instance, if a channel is detected with a PR activity, the node blacklist the channel and avoid its usage for CNP time.

At each channel selection, the channel's randomly estimated state (ES) and actual observed state (OS) are matched for its weight calculation. The binary classification of these states are shown in Figure 6.4. The channel state matching is defined as positive successful match (PSM) (ES=0, OS=0), negative successful match (NSM) (ES=1, OS=1), false alarm (FA) (ES=1, OS=0) and miss detection (MD) (ES=0, OS=1). MD occurs when a node declares an occupied channel as unoccupied and FA occurs when a node declares an unoccupied channel as occupied. Each node maintains these probabilities or channel's predictive conditions like PSM, NSM, MD, and FA, and updates only the particular condition when they occur. These accuracy test values are then used in Eq. 6.1 to determine the rank or C_w^i , which appears between 0 and 1, where 1 means the channel has the highest probability of being in OFF state. Using the C_w^i values,

Positive Successful Match (PSM)	False Alarm (FA)
TRUE POSITIVE Estimated State: 0 Observed State: 0	FALSE POSITIVE Estimated State: 1 Observed State: 0
FALSE NEGATIVE Estimated State: 0 Observed State: 1	TRUE NEGATIVE Estimated State: 1 Observed State: 1
Miss detection (MD)	Negative Successful Match (NSM)

Figure 6.4: Binary classification of channel's weight calculation parameters.

each node then maintains a sorted WCL. For example, when the estimated state appear as 1 (occupied) and actual state appear as as 0 (unoccupied), then the False alarm count will be updated only and new weight will be calculated using the updated FA count value.

$$C_w^i(\text{weight}) = \frac{(P_{PSM} + P_{FA})}{(P_{PSM} + P_{NSM} + P_{FA} + P_{MD})} \quad (6.1)$$

6.2.4 Extensions of Reactive and Proactive policies

The proposed policies are improved over an LBT approach, in which channels are selected using the existing rendezvous algorithms or WCL, at the start of a timeslot. However, during a beacon transmission phase at any stage, if a channel is detected with a PR activity, then for the rest of the timeslot the node remains silent and do not transmits any beacon. In this situation, when a PR is detected before the transmission of any beacon, then the rest of the timeslot is wasted, and due to the unknown PR activity, it can appear before any scheduled beacon. To utilize even this time efficiently, the proposed policies are extended further by repeating the channel selection process. The extension is intended to at least attempt a rendezvous by selecting a free channel instead of waiting for the next timeslot. The Reactive (RwoT and RwT) and Proactive policies are extended, as shown in Figure 6.5. The operations specific to these policies are shown in green color. The main difference is that, instead of being silent for the

remaining time of a timeslot (when PR is detected on a channel), the node will attempt to search for a free channel using the rendezvous algorithm (in case of the RwoT and RwT policies) and using a WCL (in case of the Proactive policy). The Normal policy is not intended to select a channel again, therefore, it is not been extended further.

6.3 Performance evaluation

In this section, different proposed policies are evaluated over different PR activity traffic patterns. These policies are compared against an LBT approach, because, there is no work available on policy-based evaluation of rendezvous protocols. The extension of these policies will be presented separately, at the end of this section. Each rendezvous protocol like EMCA, Random, JS [48], EXJS [49] and MMCA [40], is modified to work with these policies, and are compared to each other over different proposed policies and PR activity patterns. These policies and their impact on each rendezvous protocol with the average time to rendezvous (ATTR) and the harmful interference (HI), is also evaluated over different CNP times (the channel blacklisting periods).

The simulation setup, assumptions and performance metrics are used as same to those used in Chapter 5. IEEE 802.22 suggests the channel blacklisting time (or CNP time) as 10 minutes for TV bands [6] and 30 minutes for Radar bands [125]. The channel blacklisting time is used as 3 TS and 10 TS, as an aggressive and enhanced blacklisting for a disaster situation. A recommended CNP time of 600 timeslots (or 10 minutes) is also used for the comparison. It is possible that some channels might be detected continuously with PR activity. In that case, using those channels for PR detection and rendezvous attempts can create additional and unnecessary harmful interference. For those channels, the longer CNP times are used. The rendezvous performance is analyzed by increasing the number of nodes and channels with increasing PR activity over different CR operating policies. Table 6.1, shows the main simulation parameters, used also in Chapter 5, where nodes are placed within transmission range of each other. Each node is aware of the total number of nodes in the network but is not aware of their starting times. The results are shown using a log scale. The algorithm at each node runs until it achieves rendezvous with all the known number of nodes.

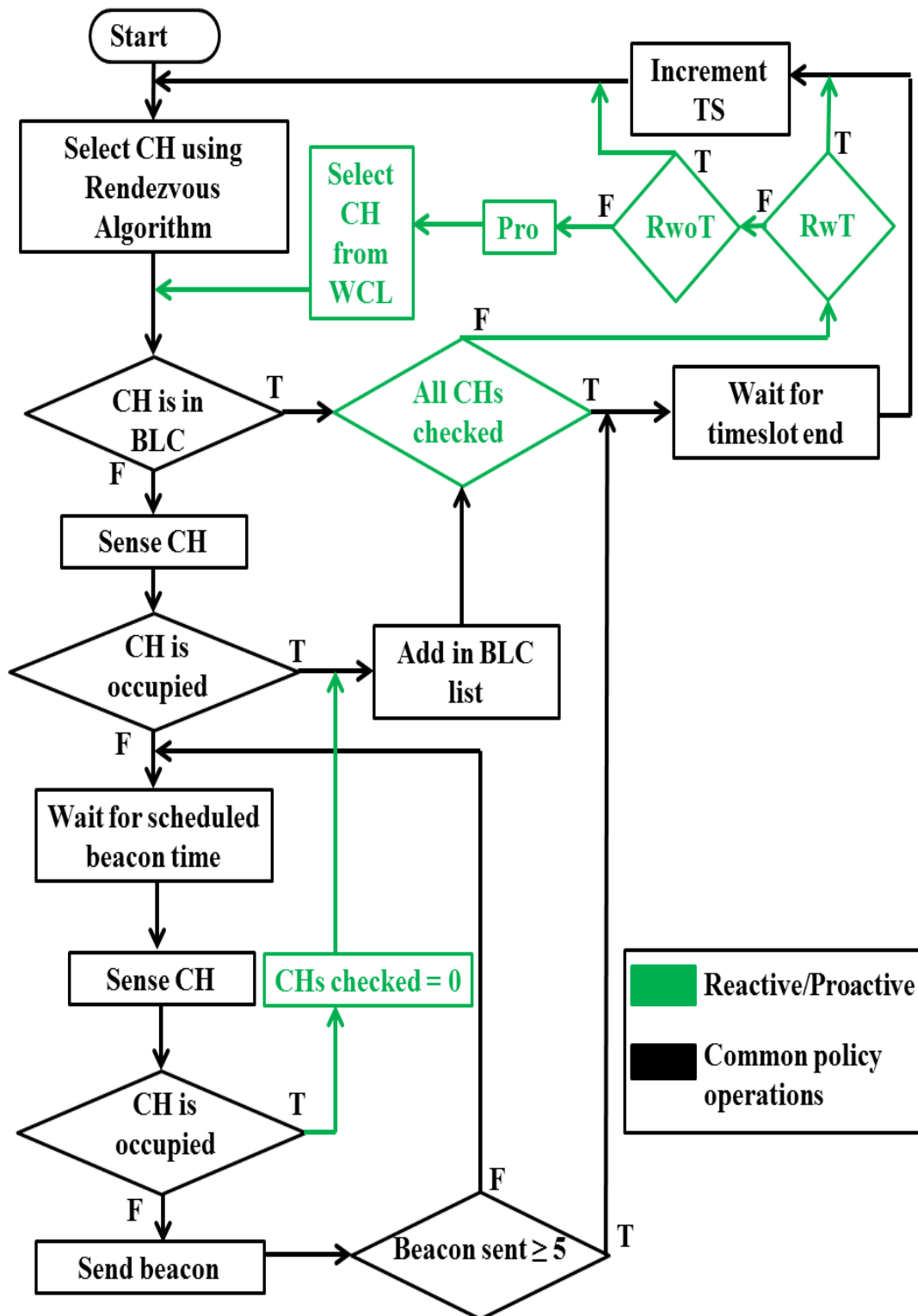

Figure 6.5: Extensions of Reactive and Proactive operating policies.

Table 6.1: Simulation Parameters

Parameters	Values
Network size	1000 x 1000 m
Number of nodes	2 and 10
Total number of channels in G	10 and 20
Total number of channels in ACS_i	7 and 14
Number of common channels	variable
T_x range	250 m
CNP time	3, 10 and 600 timeslots
Number of beacons per TS	5
Pr activity traffic patterns	Zero, Low, Long, High, Intermittent and Mix PR activity
Simulation runs	100

6.3.1 Average time to rendezvous (ATTR)

The average time to rendezvous for each rendezvous strategy over different CR operating policies and PR activities is shown in Figures 6.6 to 6.9 for 3 timeslots of CNP time. For 10 timeslots of CNP, the results are shown in Figures 6.10 and 6.11. Only zero, high and mixed PR activities results are discussed in this section, the remaining results over other PR activity patterns are given in Appendix A. The quantitative values of these ATTR results for both 2 and 10 nodes are shown in Table 6.2 and 6.3, for 10 CNP timeslots the tables are shown in Appendix B. The tables for percentage improvement of different operating policies over LBT for any particular rendezvous protocol are also shown in Appendix B, together with percentage improvement of EMCA over other rendezvous strategies.

6.3.1.1 Key observations

The key observations are given below based on the increasing primary user traffic,

Different operating policies:

- For zero PR activity, the policies do not apply and therefore do not affect the TTR for both 2 and 10 nodes, as shown in Figure 6.6.
- The impact of different operating policies is clearer, when PR activity was increased, as shown in Figure 6.7 (for High PR activity), and mixed PR activities were applied, as shown in Figure 6.8.
 - The Normal policy is slower than the others, and its TTR increases with increase in the PR activity because it stays silent on a channel which is

detected with PR activity for the whole timeslot and also blacklists the channel for a CNP time.

- The reactive and proactive policies show that this time can be used more effectively, by selecting a free channel if PR is detected on a channel at the start of the timeslot.
- Due to that immediate search of free channels, the RwoT policy improves the results for different rendezvous protocols for different PR activities.
- The Rwt policy not only searches for the free channel at the start of the timeslot but also increments the timeslot to select a new rate faster, due to which EMCA with shorter rendezvous cycle achieves more than 80% improvement over the LBT and Normal policy (Tables are shown in Appendix B).
- The Proactive policy is found to be slightly slower than Rwt. However, it tends to bring down the TTR of all rendezvous strategies to close to the level of EMCA. The Proactive policy learns the channel behavior over the time and assigns each channel a weight (i.e., the probability of a channel to be in the OFF state), and therefore all nodes converge to the best channel (in terms of the availability). This improves the chance to achieve a successful rendezvous earlier regardless of their longer rendezvous cycles.
- For all PR activities, the reactive and proactive policies are found to be more useful in bringing down the TTR.

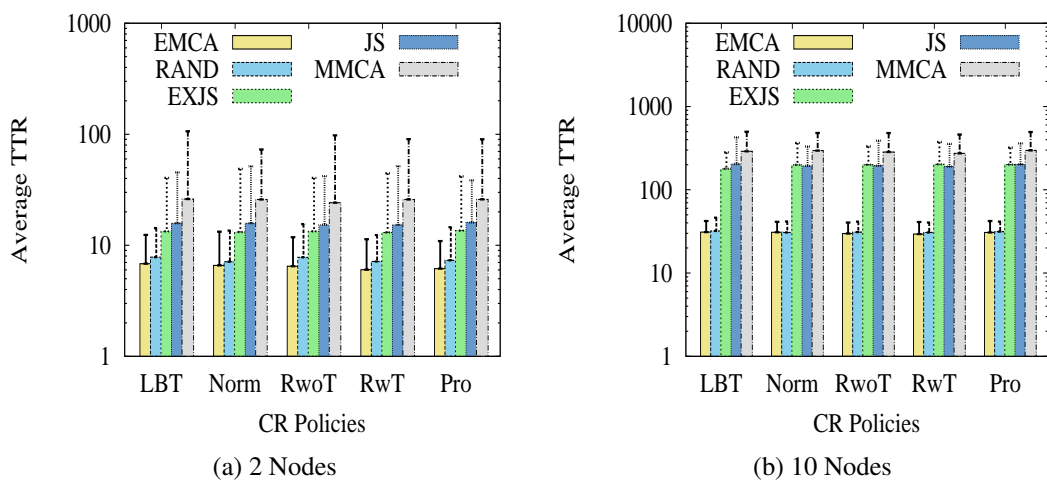

Figure 6.6: Average TTR with Zero PR activity for 7 channels and 3 BL timeslots.

Different rendezvous protocols:

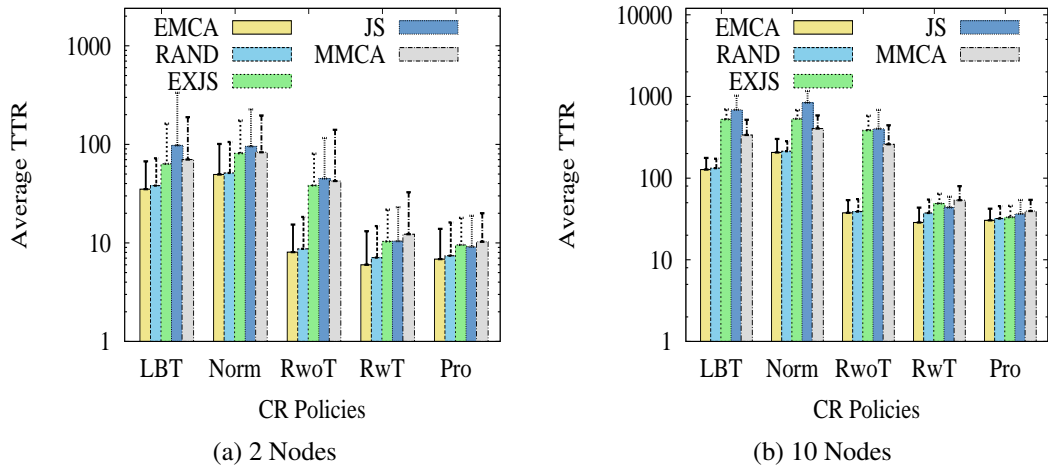

Figure 6.7: Average TTR with High PR activity for 7 channels and 3 BL timeslots.

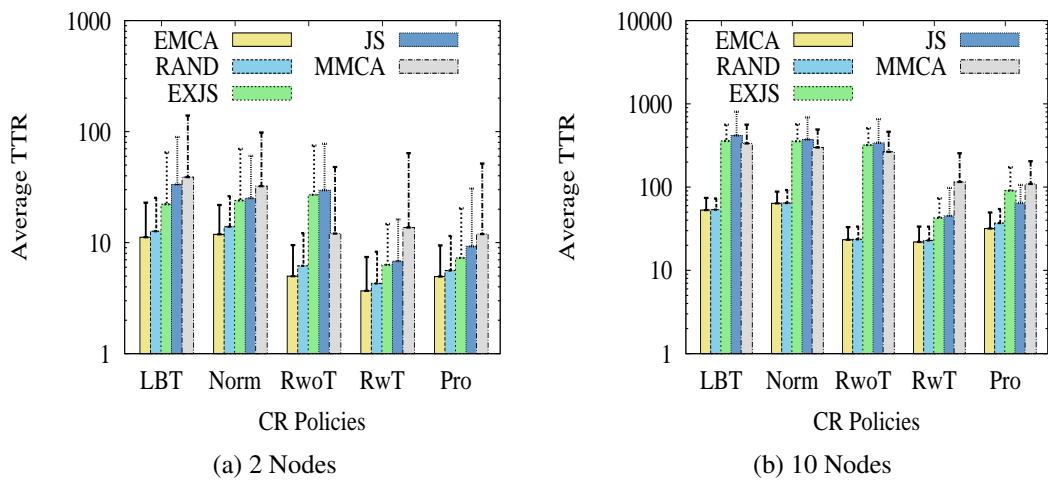

Figure 6.8: Average TTR with Mix PR activity for 7 channels and 3 BL timeslots.

- For zero PR activity, EMCA achieves the lowest time to rendezvous, and Random is only marginally slower. The MMCA, JS, and EXJS are significantly slower because their rendezvous requires longer cycles before changing the rate.
- With the increase in PR activity, the time to rendezvous of EMCA increases as well for the Normal policy, compared to an LBT approach. However, it drops to 6 and 6.84 timeslots for RwoT and Proactive policies, as shown in Figure 6.7a. For Mix PR activity (Figure 6.8a), the TTR is less as some channels have no or low PR activity, and other channels with higher PR activities are replaced mostly with less occupied channels when using the reactive and proactive policies.
- Under the High and mixed PR activities, as shown in Figures 6.7a and 6.8a, EMCA and Random still outperform all the existing blind rendezvous strate-

gies, which suffer from the longer rendezvous cycle times, even though the rendezvous guarantee no longer applies. EXJS appear as better than JS and MMCA in most cases because of its reduced rendezvous cycle length to $2P$.

- Random is still only marginally worse than EMCA. However, in the symmetric channels case, it appeared as much slower than all the rendezvous strategies (results were shown in Chapter 5).

Different PR activity traffic patterns:

- The time to rendezvous increases with increase in the PR activity traffic from zero to high. It increases mostly when an LBT and Normal policies were applied. However, when Reactive and Proactive policies were applied, the time to rendezvous was significantly less, compared to an LBT approach, which is due to an immediate search of the free channels, then staying silent on a channel.

Increasing the number of nodes:

- For 10 nodes case (Figures 6.6b to 6.8b), the average TTR increases more than in the 2 nodes case. However, EMCA and Random still outperform the existing blind rendezvous strategies with more than 80% improvement. Using the Normal policy, the EMCA took 206 timeslots to achieve rendezvous with all the nodes, however, when reactive and proactive policies were used, the TTR dropped down to 28 and 30 timeslots. These results can also be observed from the Tables 6.2 and 6.3. The percentage improvement of EMCA over existing rendezvous protocols and proposed policies over an LBT approach, are shown in Tables B.1, B.2, B.3, and B.4 in Appendix B.

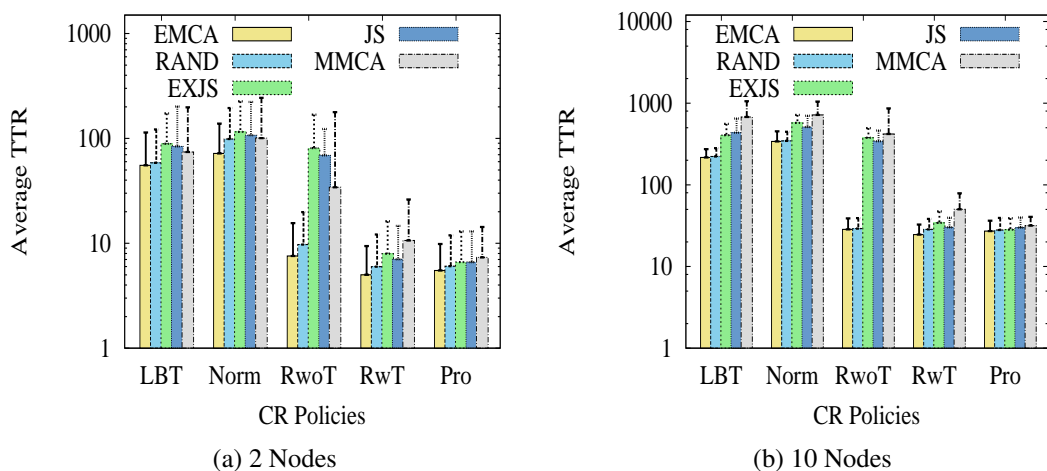

Figure 6.9: Average TTR with High PR activity for 14 channels and 3 BL timeslots.

Increasing the number of channels:

- When the number of channels is increased to 14 (Figure 6.9), the TTR is shown to be marginally lower, compared to the 7 channels case (Figure 6.7). With less number of channels and high PR activity on each channel, channels are being blacklisted more frequently, due to which the node is pushed to stay silent in a timeslot. However, with an increase in the number of channels, this situation occurs less unlikely.

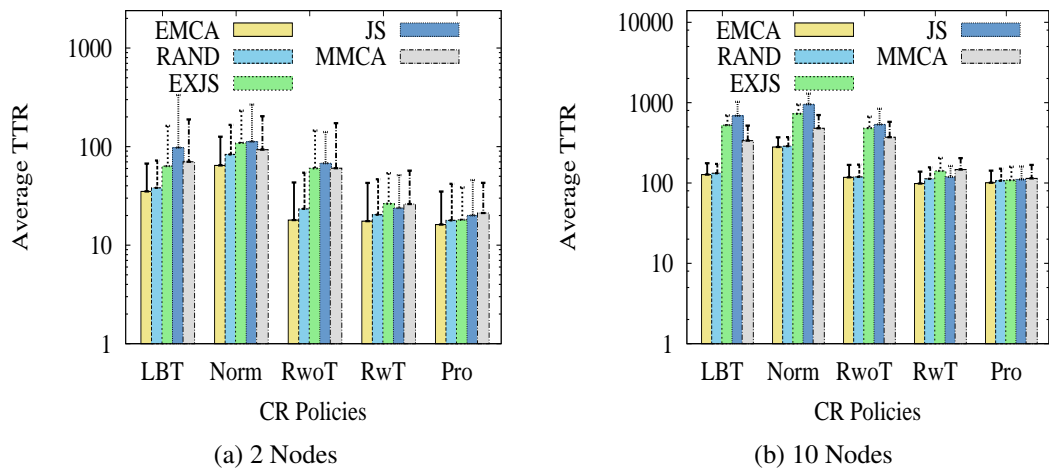

Figure 6.10: Average TTR with High PR activity for 7 channels and 10 BL timeslots.

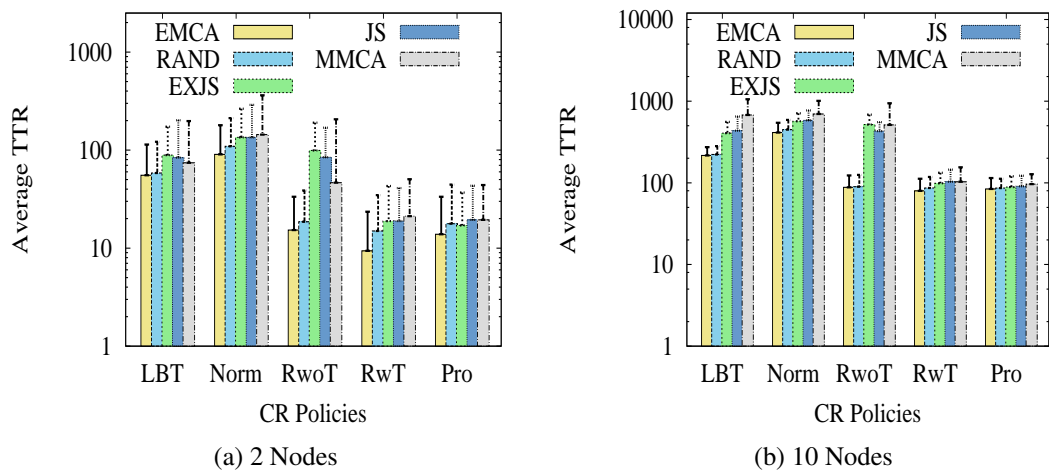

Figure 6.11: Average TTR with High PR activity for 14 channels and 10 BL timeslots.

Increasing the channel blacklisting time (i.e., CNP):

- With increase in the CNP time from 3 to 10 timeslots, as shown in Figures 6.10 and 6.11, the PR detected channels remains blacklisted for longer time. Due

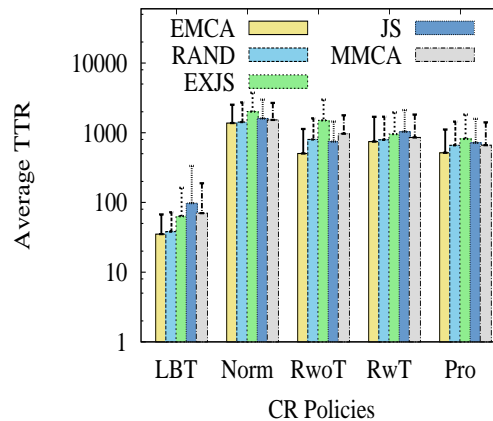

Figure 6.12: Average time to rendezvous (2 nodes, 7 channels, 600 TS CNP time, and High PR activity).

to which the time to rendezvous increases, as nodes couldn't find a free channel when the PR activity is higher. The reactive and proactive policies are also found to be with marginally higher time to rendezvous, compared to 3 timeslots CNP time case.

- When CNP time was further increased to 600 timeslots, according to the suggestion by IEEE 802.22 standard, as 10 minutes for TV bands. The time to rendezvous appear as significantly high for different policies (Figure 6.12), as compared to the results shown in Figure 6.7a for aggressive channel blacklisting time (i.e., 3 TS). The No policy does not blacklist a channel, which is why the TTR is quite low compared to other operating policies. The highest TTR is incurred by the Normal policy, as it uses the channel blacklisting and wastes time by staying silent for whole TS. The TTR for EMCA drops from 1376 TSs for Normal policy to 515 TSs for Proactive policy. Although the policies are playing their part in bringing down the time to rendezvous, the time to rendezvous still appears as significantly high.

6.3.1.2 Discussion

Overall, with increase in the PR activity, the LBT and Normal policies take longer time to achieve rendezvous due to staying silent on PR detected channels. But the reactive and proactive policies are faster as they bring down the TTR due to an immediate search of the free channel instead of wasting time, changing rate value quicker, and using learning and prediction technique. The reactive and proactive policies also appear as adaptive policies as they manage to bring down the TTR in all cases for increasing

PR activity. However, when channel blacklisting time is used as suggested, the time to rendezvous increases significantly for all policies. The suggested CNP time as 10 minutes is basically intended to reduce the harmful interference towards the PR systems. The standard bodies suggest the longer CNP and CAC durations for some spectrum bands, due to their receiver sensitivity towards the noise. These recommended values are used with the assistance of the spectrum database with a higher number of channels and with long-term spectrum measurements. However, in disaster situations for Ad-hoc networks, the spectrum databases might not be available and spectrum availability might be limited. Therefore, blacklisting channels for a longer period might degrade the rendezvous performance and also increase the network setup delay.

Table 6.2: Average TTR for single-hop (2 nodes and 3 BL timeslots)

		7 channels						14 channels					
		ZERO	LOW	LONG	HIGH	INTER	MIXPR	ZERO	LOW	LONG	HIGH	INTER	MIXPR
EMCA	No	6.82	8.79	15.25	35.09	10.96	11.19	11.62	13.51	28.58	55.36	18.71	20.69
	Norm	6.59	7.82	17.31	49.45	17.32	11.88	11.13	13.86	28.77	71.82	26.19	23.19
	RwoT	6.48	6.07	4.99	8.05	6.66	4.99	11.24	11.05	6.94	7.57	10.16	8.87
	RwT	6.02	4.38	2.95	6.00	4.99	3.67	11.23	9.06	5.09	5.01	8.67	6.83
	Pro	6.16	6.53	4.95	6.84	6.25	4.95	12.00	10.37	7.95	5.50	10.61	9.76
RAND	No	7.82	9.51	16.94	38.16	12.22	12.67	12.47	14.94	29.71	58.42	19.06	21.68
	Norm	7.11	9.95	18.88	51.22	19.30	13.89	11.48	16.97	34.62	98.61	33.24	28.19
	RwoT	7.79	6.95	5.77	8.71	6.83	6.18	12.42	12.76	7.10	9.73	11.09	9.43
	RwT	7.15	5.13	3.81	7.09	5.92	4.29	11.70	9.96	6.65	5.99	10.07	8.48
	Pro	7.32	6.81	5.73	7.41	6.63	5.61	12.62	11.68	8.70	6.05	12.08	11.87
JS	No	15.79	25.84	40.03	97.68	40.32	33.39	23.09	27.33	44.96	83.81	33.28	40.43
	Norm	15.81	24.94	40.05	95.35	44.99	25.13	20.44	25.48	42.74	107.17	46.81	52.17
	RwoT	15.30	14.36	20.70	45.00	26.41	29.61	20.92	26.50	37.79	68.90	32.17	41.68
	RwT	15.28	5.84	4.60	10.42	6.33	6.81	20.82	11.46	6.42	7.03	9.46	8.75
	Pro	16.03	8.04	6.63	9.13	7.74	9.25	20.07	12.76	9.13	6.61	11.46	11.63
MMCA	No	26.09	37.42	43.23	70.12	30.77	38.87	40.57	41.01	54.66	74.21	53.60	61.61
	Norm	25.84	38.47	47.63	83.08	28.99	32.23	41.37	45.38	55.86	100.61	44.48	78.97
	RwoT	24.20	19.96	30.72	42.41	31.95	12.08	41.22	39.84	29.40	34.15	17.89	41.09
	RwT	25.87	9.79	7.08	12.24	9.43	13.66	41.44	17.18	9.25	10.63	11.18	26.18
	Pro	25.90	9.27	7.95	10.28	8.82	11.93	39.64	16.68	9.18	7.33	12.68	12.35
EXJS	No	13.35	17.63	22.38	63.48	32.74	22.15	18.60	23.80	34.99	88.93	23.23	28.22
	Norm	13.16	24.50	34.79	81.19	42.03	23.97	18.58	22.49	48.47	115.42	50.65	32.52
	RwoT	13.38	17.82	29.73	38.29	29.74	26.96	18.70	27.66	46.97	80.88	38.47	33.23
	RwT	13.06	5.90	4.39	10.36	7.25	6.31	17.92	9.65	6.04	7.96	11.05	7.55
	Pro	13.58	8.99	5.68	9.55	7.29	7.28	18.12	13.24	9.19	6.62	11.87	12.18

Table 6.3: Average TTR for single-hop (10 nodes and 3 BL timeslots)

		7 channels						14 channels					
		ZERO	LOW	LONG	HIGH	INTER	MIXPR	ZERO	LOW	LONG	HIGH	INTER	MIXPR
EMCA	No	31.04	37.73	62.49	127.40	46.42	53.03	57.77	68.16	125.35	216.32	77.68	94.57
	Norm	30.89	41.74	77.71	206.20	74.06	63.80	57.68	72.15	148.23	340.07	126.92	113.36
	RwoT	29.83	25.69	20.16	37.58	26.94	23.34	55.73	49.91	27.80	28.48	43.08	39.88
	RwT	29.36	22.61	15.15	28.65	23.95	21.91	57.40	47.72	24.68	24.59	39.96	35.96
	Pro	30.74	25.89	20.14	30.43	24.42	31.81	57.92	50.27	32.71	27.11	43.58	53.18
RAND	No	32.01	39.39	64.17	132.39	47.77	53.58	60.68	69.06	127.24	222.39	83.62	96.05
	Norm	30.70	42.02	78.29	213.42	74.34	64.38	59.25	79.81	149.27	345.55	130.43	116.97
	RwoT	31.03	26.47	20.80	38.97	26.91	23.65	58.03	50.71	28.44	29.13	44.40	39.91
	RwT	30.73	23.90	17.97	37.40	26.84	22.89	58.91	51.22	26.09	28.48	41.41	37.05
	Pro	31.39	28.05	21.99	31.95	25.48	37.00	59.00	52.88	35.56	27.98	44.92	58.14
JS	No	203.65	252.48	421.37	687.41	386.01	415.42	129.77	150.91	223.01	435.24	212.33	196.72
	Norm	193.42	260.03	447.96	842.03	459.27	372.82	122.27	171.70	243.70	510.05	216.25	229.59
	RwoT	194.40	234.72	251.15	403.00	272.54	340.28	120.32	149.22	203.46	341.72	198.78	185.90
	RwT	190.24	27.87	23.03	43.75	27.19	45.25	117.83	54.75	28.67	30.17	42.66	45.71
	Pro	201.68	39.80	24.48	36.53	28.04	64.59	123.46	73.57	37.38	29.98	49.96	77.42
MMCA	No	289.60	298.90	316.23	337.05	301.45	334.19	467.49	504.49	587.76	676.91	535.01	510.53
	Norm	295.76	314.73	320.48	404.30	306.38	298.97	455.54	515.45	522.59	718.45	523.99	450.59
	RwoT	284.36	304.33	295.76	259.36	273.37	265.40	490.84	362.51	387.38	419.45	462.12	467.56
	RwT	273.39	69.31	53.88	53.68	54.02	115.30	436.28	102.68	56.85	50.15	65.77	202.37
	Pro	297.31	49.93	27.09	39.49	29.91	109.11	467.20	91.15	38.47	31.62	51.11	74.18
EXJS	No	178.75	188.17	276.70	524.78	298.35	358.61	112.84	127.07	220.41	405.79	158.67	177.16
	Norm	199.28	295.84	391.78	533.23	389.19	356.24	113.20	143.39	284.49	573.82	227.02	221.42
	RwoT	199.58	208.35	207.39	385.88	287.99	319.67	112.49	133.77	217.52	377.24	212.75	176.05
	RwT	202.16	32.35	26.33	48.88	32.13	42.74	108.96	54.78	31.27	34.26	46.46	47.49
	Pro	200.85	41.42	22.74	33.19	26.02	90.59	110.97	65.69	42.66	28.28	49.65	85.21

6.3.2 Average harmful interference

In Figures 6.13 to 6.15, the average number of incidents of harmful interference are shown (i.e., when CR transmission coincide with PR activity) in the same experiments as for Figures 6.7 and 6.8, for 2 and 10 nodes. For zero PR activity, no harmful interference is observed, as there is no PR activity. However, when PR activity is increased from Low to High, the harmful interference is observed (remaining graphs are given in Appendix A and Tables in Appendix B).

6.3.2.1 Key observations

The key observations for the harmful interference over the different PR activity traffic patterns and operating policies are,

Different operating policies:

- The number of harmful interference incidents are higher when an LBT and Normal policies are applied.
- When reactive and proactive policies are applied, the harmful interference is found to be less compare to an LBT and Normal policy, for both 2 and 10 nodes, as shown in Figure 6.13 and 6.14.

Different PR activities:

- For High PR activity case, the harmful interference incidents appear as higher and increase mostly due to high TTR values of different rendezvous strategies, as shown in Figure 6.13.
- For Intermittent PR activity case, the harmful interference is observed as highest overall (Figure 6.14), due to the frequent arrival of PRs on particular channels. But, with reactive and proactive policies, it drops down to below 0.1 (for 2 nodes) and 1 (for 10 nodes) incidents on average.
- With mixed PR activities, different channels have different PR activity patterns and therefore the number of incidents observed for different rendezvous protocols appear as much lower than in the High PR activity case, as shown in Figure 6.15 and 6.13.

Different rendezvous protocols:

- EMCA and Random appear as causing less harmful interference than the other blind rendezvous protocols over different PR activities.

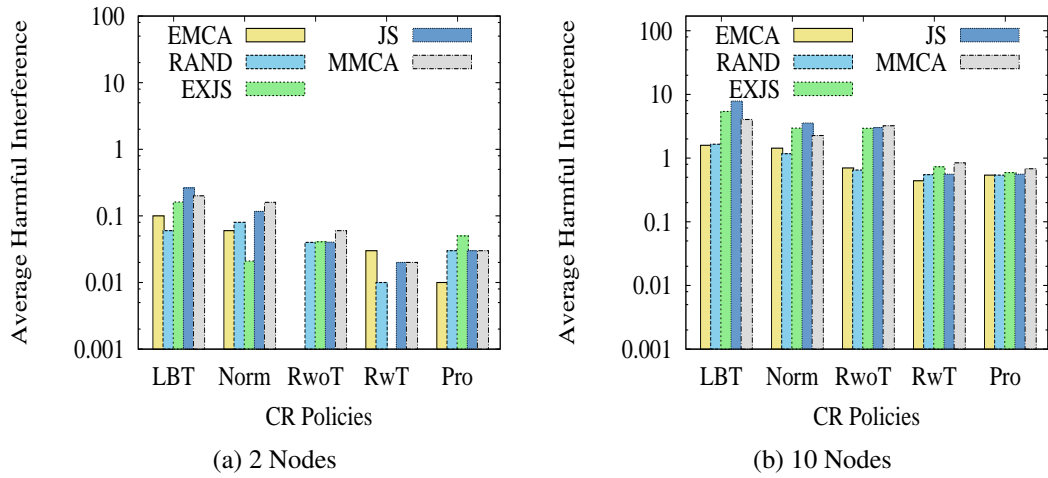

Figure 6.13: Average HI with High PR activity for 7 channels and 3 BL timeslots.

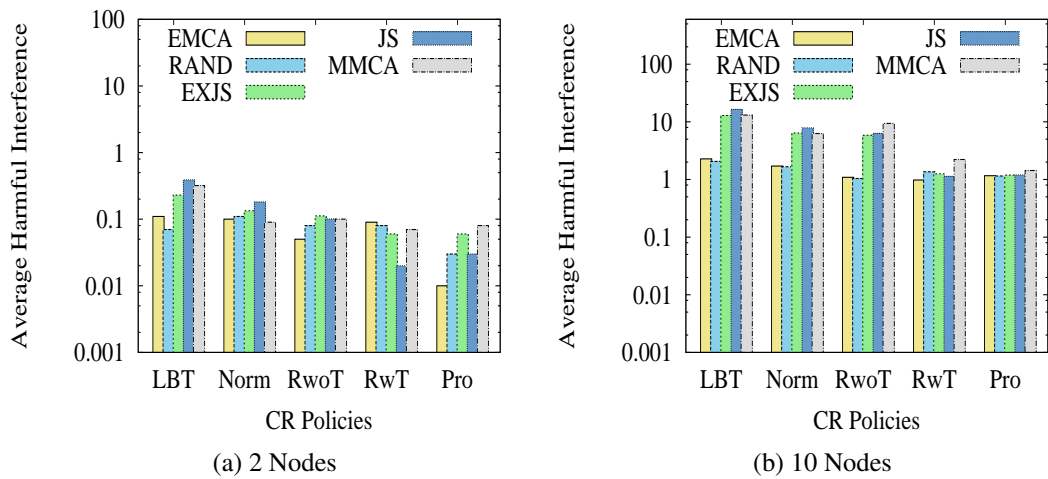

Figure 6.14: Average HI with Intermittent PR activity for 7 channels and 3 BL TSs.

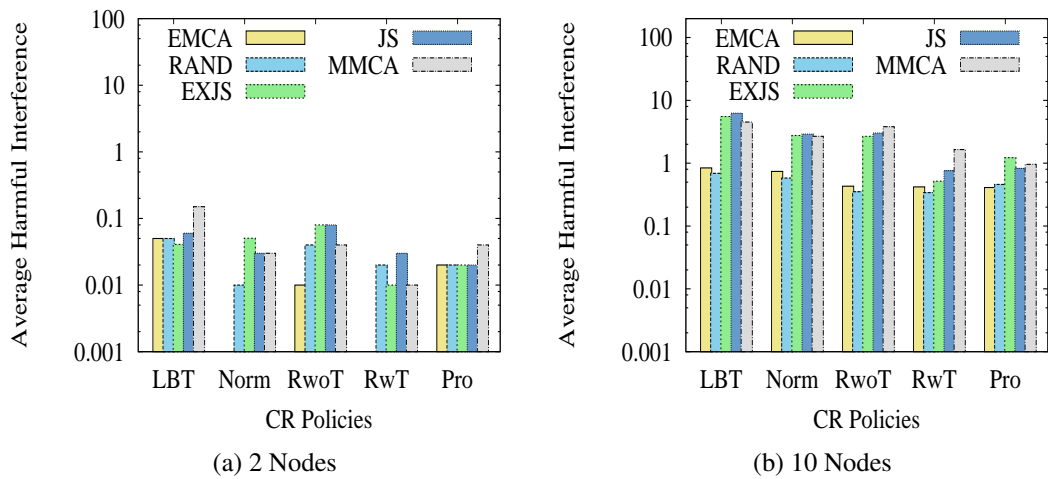

Figure 6.15: Average HI with Mix PR activity for 7 channels and 3 BL timeslots.

- The higher number of incidents for JS, MMCA, and EXJS is due to their higher TTR values. The reactive and proactive policies again show the benefits by dropping the incidents.
- At some places EMCA appear with no harmful interference at all even with PR activity, as shown in Figures 6.13a, 6.15a, 6.16a and 6.17a.

Increasing the number of nodes:

- For 2 nodes, the harmful interference appear as below 0.1 incidents on average for all rendezvous protocols, when reactive and proactive polices are used (Figures 6.13a, 6.14a, and 6.15a).
- With the increase in the number of nodes to 10, the harmful interference increases to more than 1 incidents for the LBT and Normal policies, as shown in Figures 6.13b, 6.14b, and 6.15b.

Increasing the number of channels:

- With the increase in the number of channels to 14, a marginal improvement is observed, as shown in Figure 6.16, compared to 7 channels case (Figure 6.13).

Increasing the channel blacklisting time (i.e., CNP):

- With the increase in the channel blacklisting time to 10 TSs, an improvement is observed when 2 nodes are used, and a marginal improvement is observed when 10 nodes are used, but at the cost of high TTR values, as shown in Figures 6.13 and 6.17.
- With further increase in CNP time to 600 timeslots, as suggested by the standard bodies, the harmful interference (as shown in Figure 6.18) still remains at the lowest levels of interference incidents, with marginal improvement over the other CNP times. The results show that using parameter values suggested in the standard can reduce the number of harmful incidents to some extent, but can seriously degrade the rendezvous performance.

6.3.2.2 Discussion

Overall, with an increase in the number of nodes and channels, the TTR and HI increase also. Proactive and Reactive, though are marginally better. Considering both times to rendezvous and harmful interference, the results show that EMCA with the Proactive policy is the preferred configuration, as it brings down the TTR for all ren-

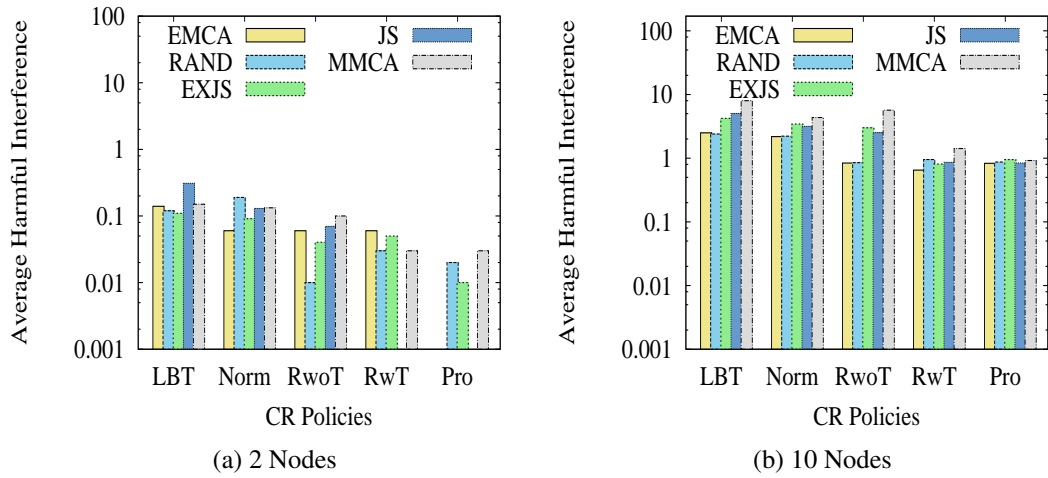

Figure 6.16: Average HI with High PR activity for 14 channels and 3 BL timeslots.

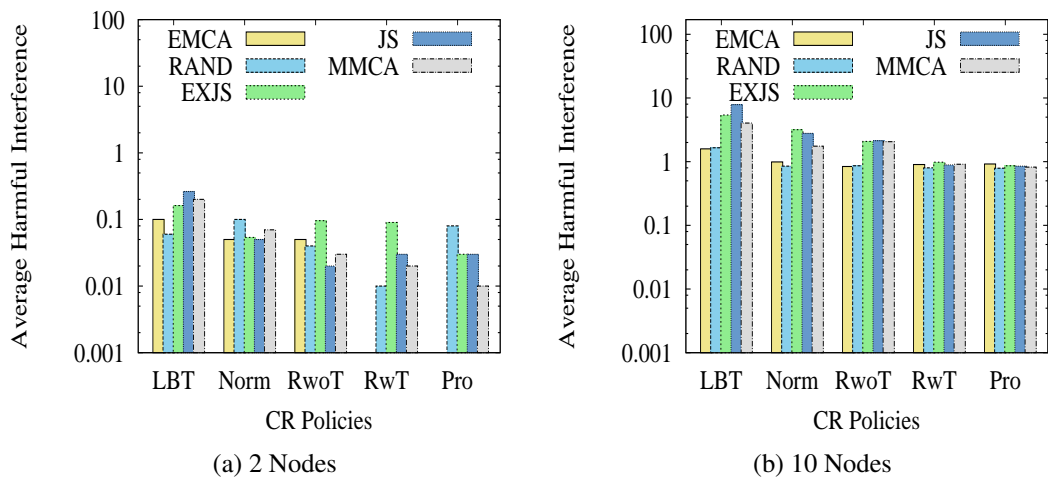

Figure 6.17: Average HI with High PR activity for 7 channels and 10 BL timeslots.

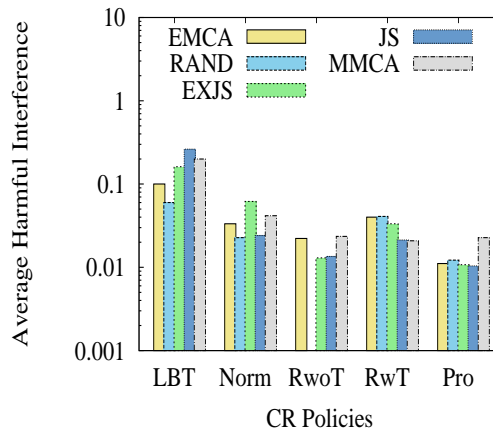

Figure 6.18: Average harmful interference (2 nodes, 7 channels, 600 TS CNP time, and High PR activity).

deztvous strategies and decreases the harmful interference as well. The enhanced channel blacklisting decreases the harmful interference incidents marginally, but at the cost of high time to rendezvous. Ideally, a CR should not create any harmful interference towards a licensed system. However, in our case, the proposed policies manages to bring down the harmful interference to its lowest level and in most cases decides not to transmit if PR appears on a channel.

6.3.3 Imperfect Sensing

For the experiments discussed so far, a perfect channel sensing model is assumed. However, an imperfect sensing is also considered, in which due to limited sensing capabilities, a cognitive radio can sense in an imperfect way. For example, it can claim an available channel as an occupied one (False alarm) or consider an occupied channel as an available opportunity (Miss detection). Figure 6.19, shows the results for average time to rendezvous and harmful interference, with imperfect sensing. The error probabilities (i.e., miss detection and false alarm) are fixed to 0.1 (or 10%), for 2 nodes and 7 channels under High PR activity. The average TTR results (Figure 6.19a), shows only a marginal increase in the time to rendezvous, as compared to the perfect sensing results shown in Figure 6.7a for all different policies. However, the harmful interference (Figure 6.19b) appear as significantly higher for No policy (LBT) with more than 50 incidents for EXJS, JS, and MMCA. The higher incidents in High PR activity are mostly due to falsely considering an occupied channel as an available opportunity. Even with imperfect sensing the EMCA outperforms the other rendezvous strategies. The reactive and proactive policies again appear as beneficial as they bring down both the harmful interference incidents much lower than 1 incident on average.

6.3.4 Extension of Reactive and Proactive policies

The proposed policies are designed to select a channel at the start of the timeslot for all policies and then follows an LBT approach for a rendezvous attempt. The reactive and proactive policies are extended further by repeating a channel selection procedure each time when a PR is detected before sending a beacon. However, to find out the proportion of time a node remains quiet after the appearance of a PR during a timeslot. A test is performed using MMCA protocol (due to its High TTR) with 2 nodes, 7 channels and 3 BL timeslots. In this test, the number of times a PR appears before sending any beacon is counted. The results in Table 6.4, illustrates that the High PR

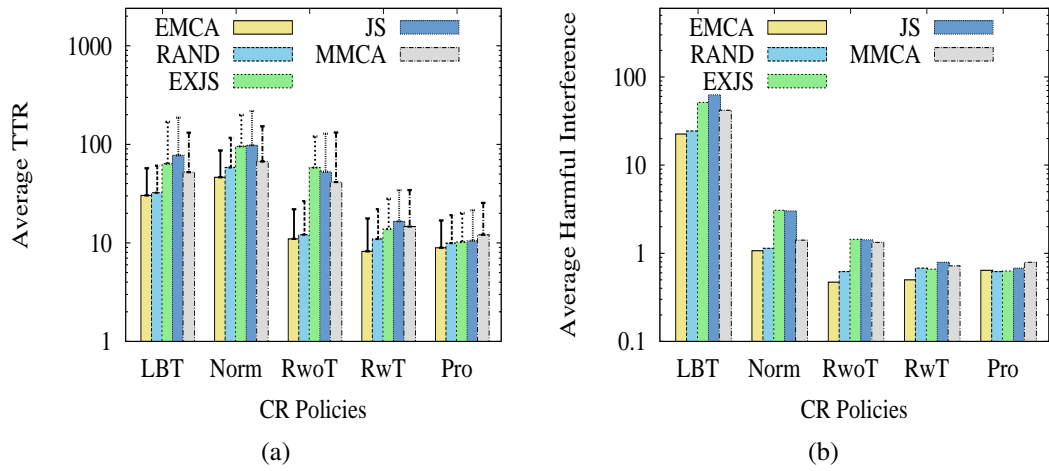

Figure 6.19: Average TTR and HI under imperfect sensing of 0.1 probability (2 nodes, 7 channels, 3 TS CNP time, and High PR activity)

activity case impacts a fixed-channel approach mostly, in which a PR appeared more number of times during a timeslot and channel is selected only once at the start of a timeslot. Therefore, the High PR activity case is used to analyse the performance of the Reactive and Proactive policies extensions (or continue search approach).

Table 6.4: Average number of times PR appears during a timeslot for a node using MMCA protocol (2 nodes, 7 CHs, and 3 BL TSs)

Nodes	PR activity	not appear	before first beacon	before second beacon	before third beacon	before fourth beacon	before fifth beacon	Total
2	zero	21.3	0	0	0	0	0	21.3
	low	8.95	1.66	0.07	0.44	0.37	0.29	11.78
	long	4.54	3.19	0.05	0.24	0.19	0.19	8.4
	high	2.64	7.27	0.12	0.5	0.36	0.28	11.17
	inter	3.44	2.8	0.24	1.16	0.73	0.57	8.94
10	zero	302.6	0	0	0	0	0	302.6
	low	61.06	4.05	0.66	3.64	3.36	3.04	75.81
	long	36.51	9.96	0.4	2.68	2.39	2.21	54.15
	high	14.66	33.97	0.85	3.94	3.03	2.37	58.82
	inter	21.25	9.45	2.3	8.28	6.26	4.88	52.42

The results are shown in Figures 6.20 (for 2 nodes) and 6.21 (for 10 nodes). The LBT and Normal policies are remain unchanged as they are designed to select the channel only once. The reactive and proactive policies are extended, to search a free channel in repeated attempts even when a PR is detected on a channel before sending a beacon. The results for average TTR (Figures 6.20a and 6.21a) shows only a marginal

improvement as compared to the fixed-channel approach (Figure 6.7). This is due to repeating the search for free channel selection. A marginal improvement is also observed when 10 nodes are used (Figure 6.21a). The harmful interference appear as less than 0.1 incidents on average for 2 nodes (Figure 6.20b) and less than 1 incident for 10 nodes overall (Figure 6.21b), when extended reactive and proactive policies are applied.

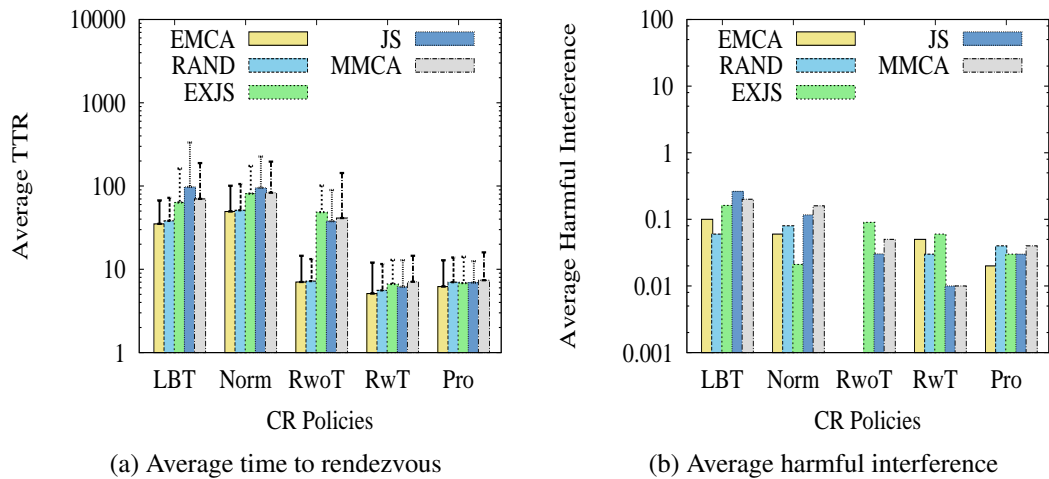

Figure 6.20: Average TTR and HI for policies extension (2 nodes, 7 channels, 3 TS CNP time, and High PR activity)

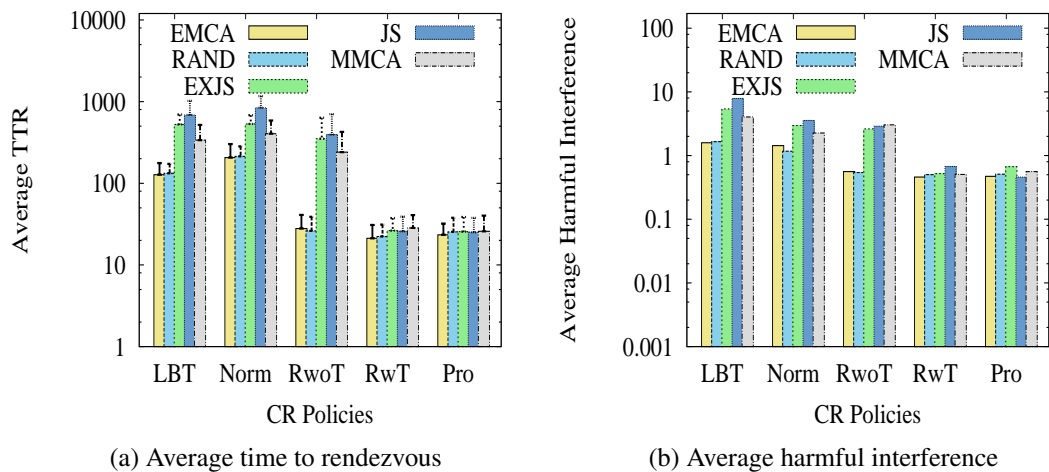

Figure 6.21: Average TTR and HI for policies extension (10 nodes, 7 channels, 3 TS CNP time, and High PR activity)

6.4 Chapter conclusion

Different CR operating policies are presented in this chapter to follow the recommendations by the standard bodies and to protect the primary radio systems from the harmful interference. These policies assist in bringing down the time to rendezvous and the harmful interference for an unknown environment. These policies are mainly improved based on the limitations of an LBT approach and can be integrated with any rendezvous algorithm to achieve the design and the performance goals. As per IEEE 802.22 suggestions, the CR must not only vacate the channel on which a PR is detected but also avoid it for some time. To follow these specifications, two blacklisting durations as channel non-occupancy periods are analyzed with different number of channels, nodes, and the PR activity patterns. With the increase in CNP duration, the time to rendezvous also increases, however the harmful interference is found to be not much affected. The Reactive and Proactive policies show benefits over the LBT and Normal policies, which wastes time by staying silent on a particular channel. EMCA shows up to 90% improvement over the existing rendezvous strategies in terms of the time to rendezvous with Random as only marginally slower. These policies are also shown to be adaptive with the unknown and increasing primary user activity. The best policy is Proactive, which prefers to return to channels with lower previous PR activity. It offers an order of magnitude improvement in time to rendezvous over basic LBT policy and improves the performance of all the studied rendezvous algorithms.

Chapter 7

A fully blind multihop rendezvous protocol

7.1 Introduction

To deploy a wireless ad-hoc network and to establish the networks services in an unknown environment, establishing a rendezvous among nodes is necessary. The problem becomes challenging when the nodes are not aware of the channels on which other nodes are operating, which is mostly referred as a blind rendezvous problem. However, when the nodes are not aware of the existence of the other nodes in a network and the topology information, the problem becomes more challenging and can be referred as a fully blind rendezvous problem. The existing literature so far includes the solutions for a blind rendezvous problem. However, a more challenging and realistic scenario for a fully blind rendezvous problem is not focused yet, which also demands to consider the cognitive radio operating policies with the unknown primary user activity, nodes, channels and topology information.

The challenges for a fully blind rendezvous problem include the efficient termination of a rendezvous process, reliable discovery of all nodes, timely discovery to reduce the network setup delay and to achieve the synchronization to establish other network services. The synchronization among the nodes is required so that the nodes can communicate at the scheduled time and channel without running the rendezvous process again. In the previous chapter (Chapter 6), the policy-based adaptive blind rendezvous protocols were presented with different CR operating policies to follow the CR specifications, to achieve the adaptiveness towards the unknown primary radio (PR) activity, to protect the PR system from the harmful interference, and to reduce the time to ren-

deztvous by searching for a free channel in a reactive and proactive way. It was assumed in Chapter 6, that the nodes are aware of the other nodes existence in the network. However, in disasters, this assumption cannot be always true as the nodes might be given a task to search for the existing nodes which they do not know initially or due to the difficulty in the physical access and mobility all the nodes may not be deployed or remain within the transmission range of each other. Therefore, in this chapter, the assumption of node awareness about the other nodes existence in the network is relaxed. However, relaxing this assumption can introduce further challenges which include the uncertainty of the total number of nodes to be discovered, the difficulty of rendezvous process termination, existence of other nodes outside one wireless hop distance and reachability to each one of them regardless of their multiple hop distances, and finally maintaining the synchronization among nodes to establish the other network services. The establishment of the network services, which rely mostly on rendezvous information demands further that after the completion of a rendezvous process, each node must be aware of all the discovered nodes and must be updated whenever a new node enters or an existing node leaves the network. Further, in disasters, nodes may not always share the same transmission range. Therefore, to address these challenges, in this Chapter, a general multihop framework is presented for a fully blind rendezvous protocol, which can work with any rendezvous algorithm.

The proposed fully blind multihop rendezvous protocol works in different phases to achieve rendezvous among multihop cognitive radio nodes. These phases are mainly intended to estimate the total number of nodes, exchange the neighbour information and establish the synchronization among the nodes to proceed towards the termination of the rendezvous process. A termination strategy is also proposed to stop the rendezvous process when all nodes are discovered. A neighbour information mechanism is also proposed to share the information among the nodes connected directly or indirectly. Due to the uncertainty of the total number of nodes and the unknown primary user activity, it is possible that some nodes might not be discovered initially. However, at any point, if a new node is discovered, its information can be shared among all the nodes. The presented multihop protocol framework can also facilitate any node which enters or leaves the network and so can help nodes to self-organize. A synchronization mechanism is also presented by which nodes can meet at any future time to exchange the rendezvous information.

The presented fully blind multihop rendezvous protocol considers the unknown primary user activity and the cognitive radio operating policies presented in the previous chapter. These policies are shown to achieve the adaptiveness towards the unknown and increasing primary user activity, and are also shown to be effective in reducing the

time to rendezvous and the harmful interference. The existing blind rendezvous strategies are modified with the presented multihop protocol framework. These modified existing blind rendezvous protocols are evaluated over different CR operating policies and primary user activity patterns. The reachability of the nodes i.e., to communicate with the nodes even after finishing the rendezvous process is also demonstrated, using a message forwarding scheme.

7.1.1 Main contributions

To summarize, our main contributions in this chapter are,

- a fully blind multihop rendezvous protocol for an unknown environment, where nodes are initially not aware of the existence of other nodes in the network.
- a rendezvous termination strategy in which a node can terminate its rendezvous process when all or sufficient nodes are discovered.
- an information sharing mechanism to share neighbour information (directly or indirectly connected) among one hop nodes to share a complete network view.
- a scheduling mechanism to achieve synchronisation among the nodes, to expedite the rendezvous process; and to exchange messages to establish other network services (after the rendezvous process has finished).
- a mechanism to re start the rendezvous process, whenever new node information is found.
- an evaluation of multihop EMCA over different cognitive radio operating policies and primary radio traffic models and comparison with different multihop rendezvous strategies, in the unknown scenarios.

7.2 System Preliminaries and Assumptions

A deployment of multiple cognitive radio nodes is assumed, which are not necessarily all in transmission range of each other (Figure 7.1). Let N denote the total number of cognitive radio nodes, where each node is unaware of N . Each radio is equipped with a transceiver, which is capable of operating over multiple channels, but can operate only on single channel at any given time. All nodes are deployed in an $L \times L$ network area.

Due to spatial diversity of channels and hardware limitations of radio transceivers, different nodes may have different subsets of spectrum bands available for communication. These subsets of spectrum bands are referred to here as Available Channels Sets (ACS). It is assumed that G is the set of all channels available in the network, where $G = \{1, 2, 3, \dots, n\}$. Each ACS_i is a subset of G .

The rest of the assumptions are as in Chapter 5 and 6;

- cognitive radio nodes can perform fast sensing to sense the medium for primary radio activity,
- the nodes use a time slotted system, with fixed timeslot durations,
- nodes are not synchronised with each other, and nodes are not aware of the starting times of other nodes.

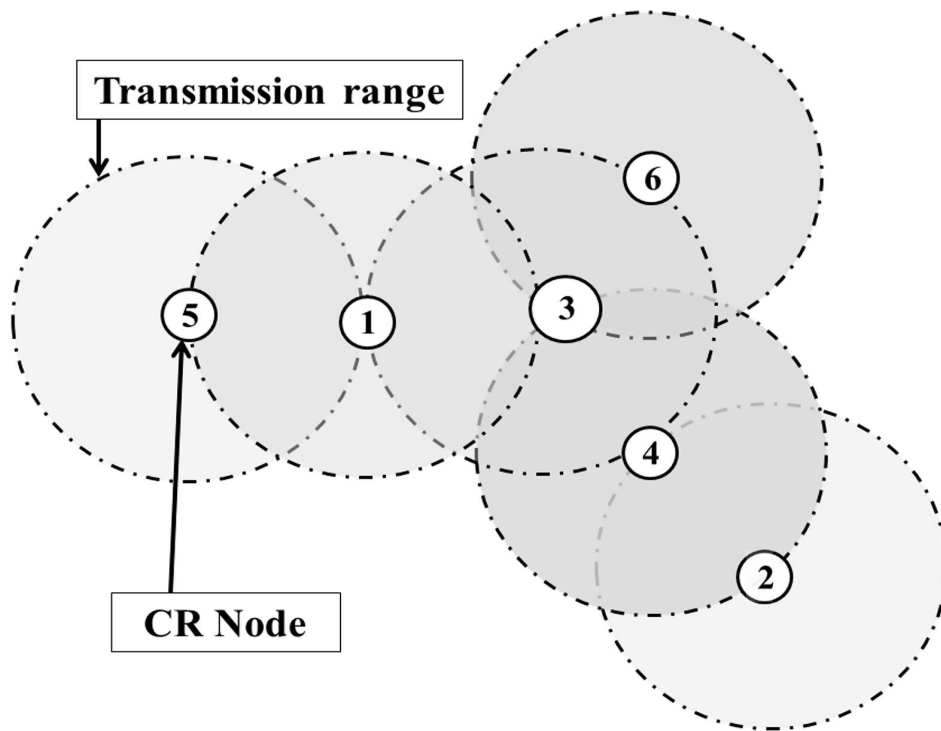

Figure 7.1: Multihop network scenario.

7.3 A multihop fully blind rendezvous framework

In the proposed multihop protocol framework, each node works in different phases to achieve the rendezvous with all neighbours and to terminate their algorithms. At every

rendezvous attempt, a node embeds into its beacon, two lists of neighbours, a Directly connected neighbours list (DNL) and an Indirectly connected neighbours list (INL). DNL contains list of neighbours to which a node can talk directly and are within one hop distance, whereas INL contains the list of those neighbours which are known to exist but with which a node can not directly communicate. As nodes are unaware of N , nodes do an estimation of N by comparing their DNLs and INLs, to proceed with the rendezvous process and its completion. The state diagram is shown in Figure 7.2. Different phases of a multihop rendezvous protocol are;

1. Rendezvous phase
2. Transition phase
3. Termination phase

To achieve rendezvous among the nodes and to terminate the rendezvous process successfully, a node will progressively move from Rendezvous to the Termination phase. Initially, a node starts in the Rendezvous phase, which runs without any time limit. At every reception, the nodes will compare their neighbours set size, and moves to the Transition phase when both the nodes have equal number of neighbours. Otherwise, will schedule a rendezvous point, if not already existed using a controlled rendezvous. Nodes achieve rendezvous with their one hop neighbours in the Rendezvous phase. Once the nodes move to the Transition phase, they cannot go back to the Rendezvous phase. The Transition phase is a middle phase between the Rendezvous and the Termination phase, which runs for a specified time. The Transition phase time limit is set according to the time required to achieve a rendezvous between one hop neighbours in a worst case scenario (i.e., the High PR activity in previous Chapter 6). In Transition phase, the nodes will sense the medium and transmit beacons, until either a transition phase timer is expire or a new node is found. When a new node information will be found, the Transition phase timer will start again. The node moves to the Termination phase, when its Transition phase time limit expires. However, at any point if any node acquires a new information, it cancels its Termination phase, restart its Transition phase time, and moves back to the Transition phase. In Termination phases, nodes exchange their intentions to Terminate the rendezvous process, and change their status to Terminated by mutual consent among their one hop neighbours. When a node sends a beacon with a Termination request, the other node sends an ACK back with an agreement to Terminate, if it is also in the Termination phase. Once Terminated, the nodes will not send any beacons, but can receive a beacon and can send back ACK messages to help other nodes to Terminate their rendezvous process.

The Algorithm 2 and state diagram shown in Figure 7.2, shows the receiver side operation. The sender side operation for channel decision including the CR operating policies are given in Chapter 5 with a handshake process. Even after the rendezvous process has finished, if any node finds a new neighbour information direct or indirect, that node will cancel its Terminated status and move back to the Transition phase. The node will start sending beacons to share the new information and other nodes which receives them will do so also.

7.3.1 Rendezvous Phase

In this phase, nodes start their rendezvous process normally using a rendezvous algorithm, without any time limit. In this phase, the nodes will try to achieve rendezvous with its one hop neighbours and shares information about their direct and indirect neighbours with channels information. However, when a node finds its number of neighbours (direct and indirect) is equal to the sender node's neighbours, it will move to the Transition phase, and sends an ACK with a flag to tell the other node to do so also. While comparing the DNLs and INLs, the nodes with which the receiver has not talked directly will be added to the INL of the receiver node. However, if the neighbours are not equal, then the node will continue its rendezvous phase. The nodes will also exchange a scheduling point by exchanging a particular timeslot and a channel, to meet at a future time to share and update their neighbour information. Once the receiver encounters a rendezvous with any node that already exist in its INL, it will move it from its INL to the DNL. Once a node moves from the Rendezvous phase to the Transition phase, it will not go back to it.

7.3.2 Transition Phase

The Transition phase is different from the Rendezvous phase, as it runs with a time limit. However, if new information is found in between, the Transition phase will start again, and in any case the node will not move back to the Rendezvous phase. The transition phase is meant to provide extra time to a node to achieve rendezvous with the nodes in its INL and to which a node could not talk while in the Rendezvous phase due to the unknown PR activity. If a node encounters a rendezvous in this phase with a new neighbour or finds new information about any indirectly connected neighbour, the transition phase will start again. At every beacon reception, a node in Transition phase compares and matches the DNL and INL IDs; and starts again if they are not

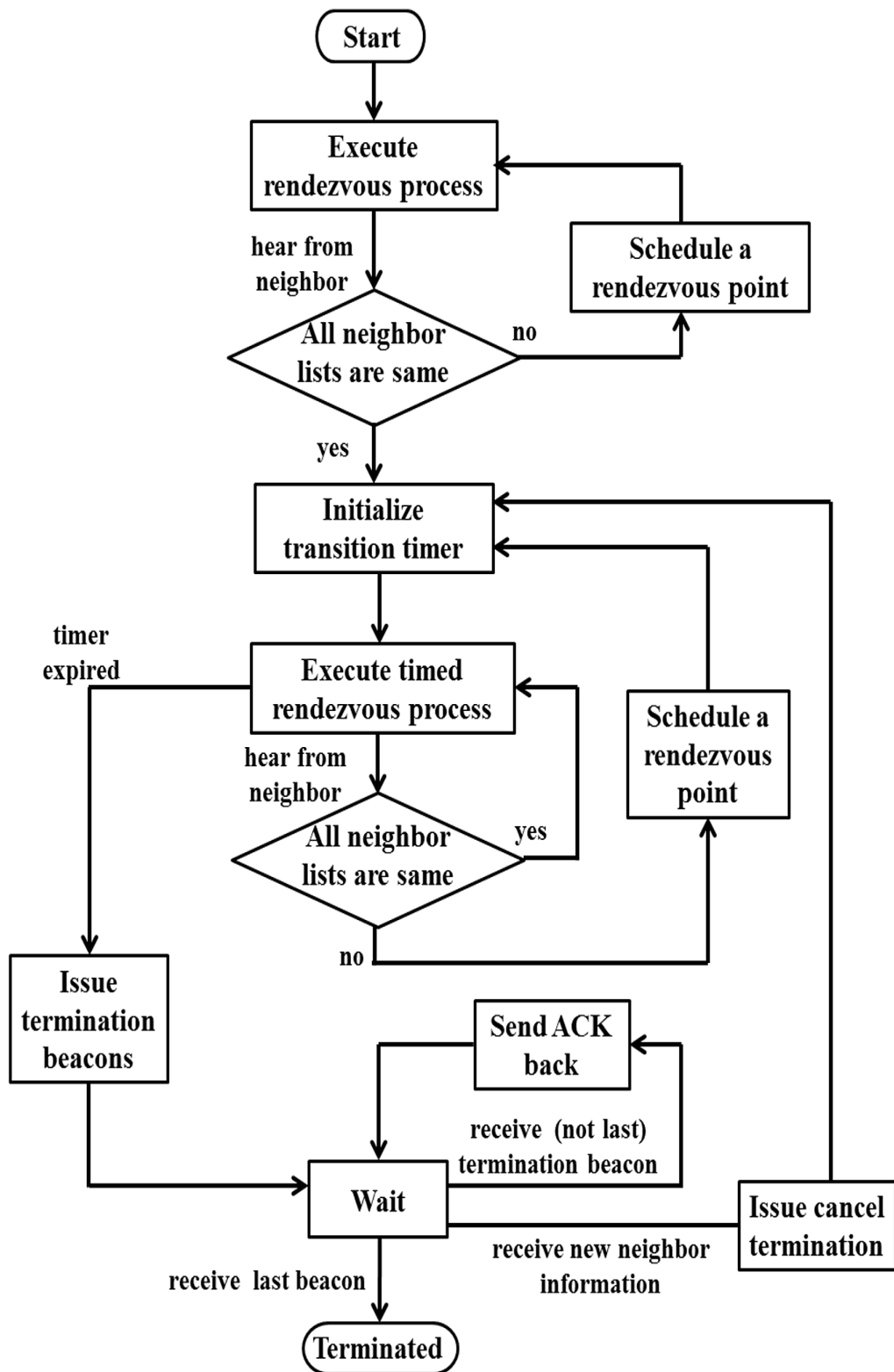

Figure 7.2: Multihop rendezvous protocol state diagram.

equal. A rendezvous point is also scheduled, if not scheduled already between any pair of direct neighbours using a Controlled Rendezvous (which handles the scheduling among the directly connected neighbours), to be sure that none of the nodes have missed any neighbour entry. This will help out in distributing a complete network view across a network and to achieve synchronization among nodes. After the expiry of the Transition phase, the nodes will automatically move to the Termination phase, where they will start their Termination process.

7.3.3 Termination Phase

In the Termination phase, the nodes will move towards the termination of rendezvous process by exchanging messages and confirming to each other about their termination stage. Once a node receives a beacon which confirms the start of the Termination stage of the sender, the receiving node will update the sender node's status as Terminated, and inform the sender about its status by sending an ACK (provided the receiver is also in the Termination phase). The sender on reception of an ACK will change the receiver's status also to Terminated. A node will wait until it receives from all of its directly connected neighbours, a beacon with a termination request or an ACK which confirms their Termination decision, after which it can terminate its rendezvous process. While Terminated, the nodes will not send any rendezvous beacons to attempt a rendezvous. However, if they receive any beacon with a request from the sender about the Termination, the node will send back an ACK message, to confirm their Terminated status. However, if any new information is found during that time, the nodes will move back to the Transition phase and cancel their Terminated status. This will facilitate the information dissemination of any new neighbour arrival, even after the rendezvous process has Terminated. It is presented in Algorithm 2 at Lines 117 to 130.

After a node status is changed to Terminated, it can start establishing other network services like Routing or data transmission. However, for a disaster application, it is necessary to check for the new neighbour arrivals and confirmation of previous neighbour information from time to time. Therefore, rendezvous process can start again in a periodic way from the Transition phase, which also involves the scheduling mechanism to update the neighbour information. Depending on the application requirement, the rendezvous process can be adjusted, i.e., to run for a long time to collect all or most of the neighbour information; run periodically to look for new information and confirm the previous information; or run in parallel with other network services in every timeslot.

Algorithm 2 Multihop Rendezvous Protocol

```

1:  $DNL$ , Direct Neighbour List of node
2:  $INL$ , Indirect Neighbour List of node
3:  $i$ , Sender node id
4:  $k$ , Receiver node id
5: Initialize  $Transition-Phase-Counter_k = 0$ , the time counter for the Transition
   phase
6: Initialize,  $t_k = 0$ , the timeslot of receiver node  $k$ 
7: Initialize,  $phase_k = RENDEZVOUS$ 
8: Initialize,  $status_k = \text{Not TERMINATED}$ 
9: while  $status_k \neq \text{TERMINATED}$  do
10:    while  $t_k$  not finish do
11:        if Beacon is received then
12:            if Receiver ID is in  $DNL_i$  then
13:                if Sender ID is in  $DNL_k$  then
14:                    call procedure Multihop Rendezvous Phases
15:                else
16:                    Add Sender ID in  $DNL_k$ 
17:                    if Sender ID exist in  $INL_k$  then
18:                        Remove from  $INL_k$ 
19:                    end if
20:                    call procedure Multihop Rendezvous Phases
21:                end if
22:            else
23:                Send ACK to sender about successful reception of beacon
24:                if Sender ID exist in  $INL_k$  then
25:                    Remove from  $INL_k$ 
26:                end if
27:                call procedure Multihop Rendezvous Phases
28:            end if
29:        end if
30:
31:        if ACK is received then
32:            if  $ID_i$  is not in  $DNL_k$  then
33:                Add in  $DNL_k$ 
34:            if exist in  $INL_k$  then
35:                Remove from  $INL_k$ 
36:            end if
37:            if  $status_k = \text{TERMINATED}$  then
38:                change  $status_k = \text{NOT TERMINATED}$ 
39:                change  $phase_k = \text{TRANSITION}$ 
40:                Restart  $Transition-Phase-Counter_k$ 
41:            else if  $phase_k = \text{TERMINATION}$  then
42:                change  $phase_k = \text{TRANSITION}$ 
43:                Restart  $Transition-Phase-Counter_k$ 
44:            else if  $phase_k = \text{TRANSITION}$  then
45:                Restart  $Transition-Phase-Counter_k$ 

```

```

46:         end if
47:     end if
48:     if TRANSITION flag is True then
49:         phasek = TRANSITION
50:     end if
51:     if TERMINATED flag is True then
52:         Update neighbour termination status
53:         if all neighbours have terminated then
54:             statusk = TERMINATED
55:         end if
56:     end if
57:     if received a schedule request then
58:         if not already scheduled then
59:             Schedule a rendezvous time
60:             call procedure Controlled Rendezvous
61:         end if
62:     end if
63: end if
64:
65: procedure MULTIHOP RENDEZVOUS PHASES
66:     if phasek = RENDEZVOUS then
67:         if Neighbours of i == Neighbours of k then
68:             phasek = TRANSITION
69:             send an ACK to sender to move to TRANSITION Phase
70:         else
71:             call procedure Controlled Rendezvous
72:         end if
73:         Compare DNLi and INLi with DNLk and INLk
74:         if New information found then
75:             Add in INLk
76:         end if
77:     else if phasek = TRANSITION then
78:         if TRANSITION phasek counter is expired then
79:             phasek = TERMINATION
80:         else
81:             call procedure Controlled Rendezvous
82:         end if
83:         Compare DNLi and INLi with DNLk and INLk
84:         if New information found then
85:             Add in INLk
86:             Restart Transition-Phase-Counterk
87:         end if
88:     else if phasek = TERMINATION then
89:         if phasei = TERMINATION then

```

```

90:          Compare  $DNL_i$  and  $INL_i$  with  $DNL_k$  and  $INL_k$ 
91:          if New information found then
92:              Add in  $INL_k$ 
93:               $phase_k =$  TRANSITION
94:              Restart Transition-Phase-Counterk
95:          else
96:              if sender has not already received the Termination confir-
          mation then
97:                  Send an ACK to sender to confirm Termination
98:              end if
99:          end if
100:         end if
101:         end if
102:         end procedure
103:
104:         procedure CONTROLLED RENDEZVOUS
105:             if  $ID_k$  and  $ID_i$  are not already scheduled then
106:                 Find common channels among  $ID_k$   $ID_i$ 
107:                 Schedule a rendezvous time
108:                 send an ACK to sender about the scheduled time and channel
109:             end if
110:         end procedure
111:     end while
112:      $t_k = t_k + 1$ 
113:     if phase = Transition then
114:         Increment Transition-Phase-Counterk
115:     end if
116: end while
117: if  $status_k =$  TERMINATED then
118:     if rendezvous beacon received then
119:         if request received for changing status to TERMINATED then
120:             Send a flagged ACK to sender for changing its status to TERMI-
          NATED
121:         end if
122:         Compare  $DNL_i$  and  $INL_i$  with  $DNL_k$  and  $INL_k$ 
123:         if New information found then
124:             Add in  $INL_k$ 
125:              $status_k =$  NOT TERMINATED
126:              $phase_k =$  TRANSITION
127:             Restart Transition-Phase-Counterk
128:         end if
129:     end if
130: end if

```

7.4 Scheduling and synchronisation among nodes

A general multihop rendezvous framework is presented in the previous Section 7.3 to achieve a rendezvous among nodes, when initially the nodes are unaware of the existence of other nodes in the network and the topology information. The proposed multihop framework includes a scheduling mechanism to achieve synchronisation among nodes even after the rendezvous process has terminated. The term scheduling is used here to allocate or schedule a channel and time between the nodes to meet at later time. Similarly, the synchronization can be achieved among nodes when they meet at the scheduled time and channel to exchange the information without running the rendezvous process again. It is expected at the end of the multihop rendezvous process that:

- every node has discovered all or most of the neighbours;
- each node has collected the information of its directly and indirectly connected neighbours;
- each node now knows its directly connected neighbours and the channels they are using;
- each node has achieved synchronisation among its direct neighbours and has an agreed schedule to meet at a future time;
- each node can exchange messages between their one hop neighbours using an agreed schedule which includes the time and the channel to establish other network services.

The nodes will exchange the rendezvous schedule information, if not already existed, to meet at a common channel. Then each node tunes into an agreed channel at the scheduled time to exchange rendezvous beacons or any other message. The scheduled event once finalised between two nodes, repeats at a regular interval, to help achieve the synchronisation and communication among nodes after a rendezvous process has finished. The rendezvous process can restart at any stage when a new neighbour information is found.

7.5 Simulation Environment

In this section, the simulation environment is presented which is used for the evaluation of the multihop EMCA rendezvous protocol and other rendezvous strategies. The

proposed protocol is evaluated over different CR operating policies and PR activity traffic models.

7.5.1 CR operating policies

The CR operating policies are already explained in Chapter 6. The algorithms of different CR operating policies (LBT, Normal, Reactive and Proactive) are still applicable without any changes. The channel selection decisions are mainly part of the sender-side operations, and are explained in Chapter 6 with the operating policies.

7.5.2 Existing multihop rendezvous strategies

The EMCA multihop blind rendezvous protocol is compared against JS [48], EXJS, MMCA [40] and Random strategies. These rendezvous strategies are not designed for unknown number of nodes in a multihop environment. Therefore, these protocols are modified with our multihop blind rendezvous framework with CR operating policies for a fair comparison. These existing strategies are modified according to the Algorithm 2, which represents the receiver-side operation and decisions to achieve rendezvous among multiple and multihop nodes. In the modified version of these rendezvous protocols, each node selects the channel using their rendezvous algorithm and particular operating policy, and then use the multihop framework for the decisions to move progressively from one phase to another until the termination of the algorithm.

7.5.3 Network Environment

The 3 and 10 nodes scenarios are used, to evaluate the multihop blind rendezvous strategies. The 3 nodes are used to analyse the performance for the minimum hop distance i.e., 2. The 10 nodes are used to analyse a scenario where hop distance increases. For each experiment, a random topology was generated with a maximum hop distance as 4 hops, in a network area of $1000 \times 1000 \text{ m}^2$. All nodes are deployed randomly in a multihop manner. The nodes are not aware of the existence and the positions of the other nodes in the network. Each ACS_i selects a subset of channels out of G randomly. The ACS_i includes 7 and 14 channels, selected out of G of 10 and 20 channels. The nodes are not aware of the random starting times of other nodes. The primary radio activity traffic patterns are used as defined in Chapter 5, and are also unknown to the nodes. The channel non-occupancy period is used as 3 TSs and 10 TSs for blacklisting

a channel. Same parameter values are used to generate the traffic patterns, as explained in Chapter 5.

7.5.4 Performance Metrics

The goal is to discover the maximum number of nodes, when the nodes are not aware of the existence of the other nodes in the network, their channel information, topology and random starting times. The following metrics are used to evaluate the performance of the proposed EMCA based multihop rendezvous protocol:

1. **Average Time to Rendezvous (ATTR):** For known number of nodes the term ATTR is defined already in Section 5.5.1 of Chapter 5. For unknown number of nodes assumption, it can be re-defined as the time from when the first node starts its rendezvous process to the time when the last node Terminates its rendezvous process.
2. **Average Harmful Interference (HI):** It is already defined in Section 5.5.1 of Chapter 5.
3. **Average Neighbour Discovery Accuracy (NDA):** the average accuracy of discovered neighbours by each node, connected directly or indirectly, and measured as a percentage of the actual number of neighbours.
4. **Reachability:** the percentage of the total number of nodes which receives a copy of the message forwarded after the rendezvous process has finished.

7.6 Performance Evaluation

In this section, different fully blind multihop rendezvous protocols are evaluated using different CR operating policies and PR activity traffic patterns. Each result is an average of 100 simulation runs and graphs are shown in log scale, for clarity.

7.6.1 Average Time to Rendezvous

The average time to rendezvous results for each multihop rendezvous protocol for both 3 and 10 nodes are shown in Figures 7.3 to 7.5 (for 7 channels) and Figure 7.6 (for 14 channels). The quantitative values are shown in Tables 7.1 and 7.2, for 3 CNP timeslots. For explanation, only the Zero, High and Mix PR activity traffic models

are focused here. However, remaining traffic models are shown in Appendix A, and their Tables (including both the quantitative values and the percentage improvement of EMCA over the existing strategies) are shown in Appendix B.

7.6.1.1 Key observations

The key observations are highlighted below based on the increasing PR traffic,

Comparison with single-hop case:

- The time to rendezvous compared to the single hop case (Chapter 6) is much higher, because in multihop case the nodes are unaware of the number of nodes and topologies, and therefore takes longer time to finish the rendezvous process. This involves an infinite Rendezvous phase, a finite Transition phase, and a Termination phase to terminate the rendezvous process by a mutual consent.

Different operating policies:

- For zero PR activity, the policies do not apply and therefore do not affect the TTR for both 3 and 10 nodes, as shown in Figure 7.3. With increase in the PR activity, the effect of policies is clearer, as shown in Figures 7.4 and 7.5, for High and mixed PR activities.
- The Normal policy is found to be worst in terms of the average TTR among all the policies, as it blacklists the channel on which PR is detected and stays silent for the whole timeslot. However, in comparison with the LBT and Normal, the Reactive and Proactive policies are found to be better in terms of the average TTR, under both the High and Mixed PR activities. The Reactive and Proactive policies were also shown as better than LBT and Normal policy in Chapter 6.
- The Proactive policy brings down the TTR of all rendezvous strategies, due to its learning capability.
- For Mix PR activity (Figure 7.5), the LBT and Normal seems to be improving the TTR compared to High PR activity case, because of different PR activities at different channels. However, for Reactive and Proactive the TTR is found to be only slightly better than the High PR activity, due to the time a node spends in each multihop phase.
- Overall, the average TTR increases with increase in the PR activity. However, the operating policies are found to be beneficial in bringing down the TTR for the multihop protocols.

Different rendezvous protocols:

- The EMCA outperforms all the other multihop blind rendezvous protocols and Random is found to be only marginally slower, under different PR activity traffic patterns. The other protocols appears as much slower because their rendezvous requires longer cycles before changing the rate.
- The JS and EXJS are found to be slower than MMCA, due to their stay period.
- The percentage improvement of EMCA over other multihop rendezvous protocols is found to be 60% in most cases, but in some cases it appears as more than 60% (Tables are shown in Appendix B).

Increasing the number of nodes:

- When the number of nodes are increased to 10, the TTR increases under High and Mix PR activity, as shown in Figures 7.4b and 7.5b. The TTR increases more than the 3 nodes case, but, not a significant increase is observed, as was observed in single hop case (Chapter 6). That shows increasing the node density is not affecting the TTR, as every nodes runs the rendezvous process simultaneously and spending time in different phases, gives the node enough time to reach the Termination phase and to Terminate.

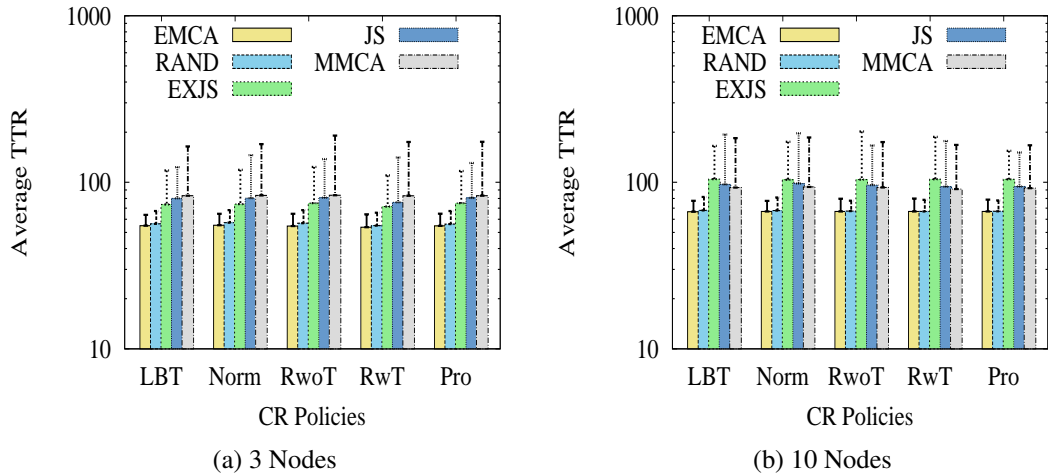

Figure 7.3: Average TTR for multihop (7 ch, 3 BL TSs and Zero PR activity).

Increasing the number of channels:

- With an increase in the number of channels to 14, the TTR increases as well for the LBT and Normal policies, as shown in Figure 7.6, and compared to 7 channels (Figure 7.4). However, for the Reactive and Proactive policies, the TTR is dropping on average, similar as in 7 channels case (Figure 7.4).

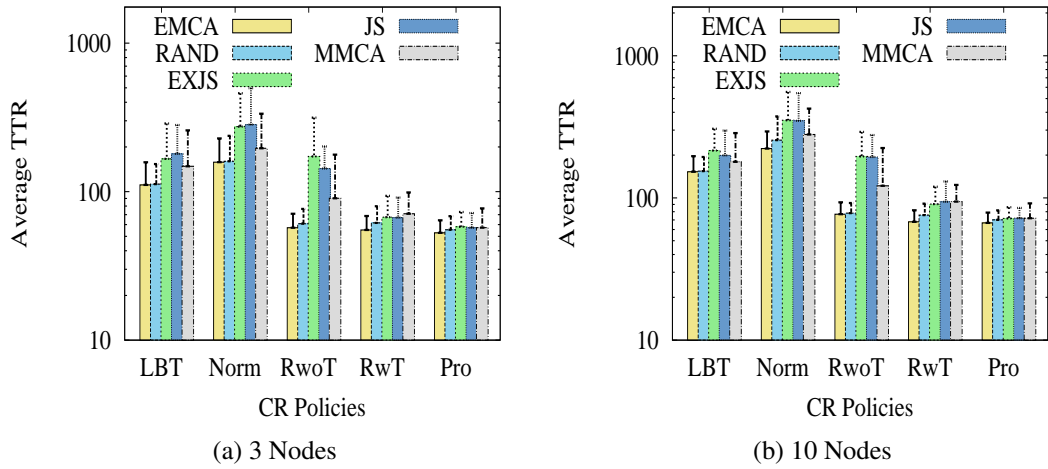

Figure 7.4: Average TTR for multihop (7 ch, 3 BL TSs and High PR activity).

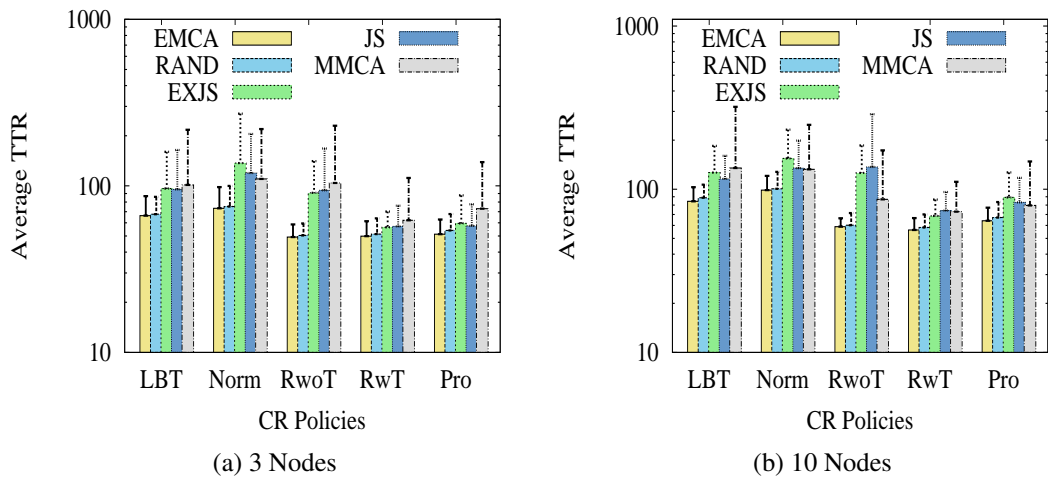

Figure 7.5: Average TTR for multihop (7 ch, 3 BL TSs and Mix PR activity).

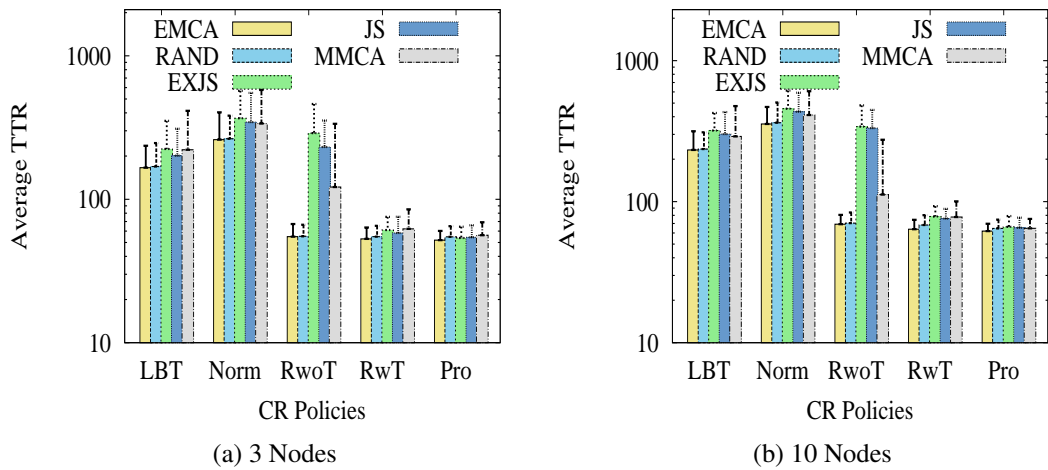

Figure 7.6: Average TTR for multihop (14 ch, 3 BL TSs and High PR activity).

- The proactive policy is found to be better in the higher number of channels case, as it converge to best channels, as shown in Figure 7.6.
- Overall, increasing the number of channels does not affect the time to rendezvous very much when reactive and proactive policies are used.

Increasing the channel blacklisting time (i.e., CNP):

- With an increase in the channel blacklisting time (or CNP time) to 10 TSs, the time to rendezvous increases also, as shown in Figure 7.7 (for 7 channels) compared to 3 TS CNP time (Figure 7.4).
- The increased CNP time is mainly intended to reduce the harmful interference, but it also affects the time to rendezvous, as due to longer blacklisting times the nodes find less opportunities to attempt a rendezvous, due to which the TTR values are higher.
- The Reactive and Proactive policies again appear as beneficial, as they bring down the TTR compare to the Normal policy. However, due to increase in the TTR they appears to be only slightly better than the LBT, where node attempts rendezvous without blacklisting the channels.
- With further increase in the CNP time to 600 timeslots (i.e., 10 minutes, as suggested by IEEE), the average time to rendezvous is found to be significantly higher compared to 3 and 10 BL timeslots which is due to the longer durations of channel blacklisting (Figure 7.8).
- The Normal policy is found to be worst. The reactive and proactive policies manage to bring down the average TTR, but still the time to rendezvous is found to be significantly higher, compared to the aggressive and enhanced channel blacklisting times.
- LBT shows no effect, as it does not involve channel blacklisting. Overall, with increase in the channel blacklisting time, the time to rendezvous also increase.

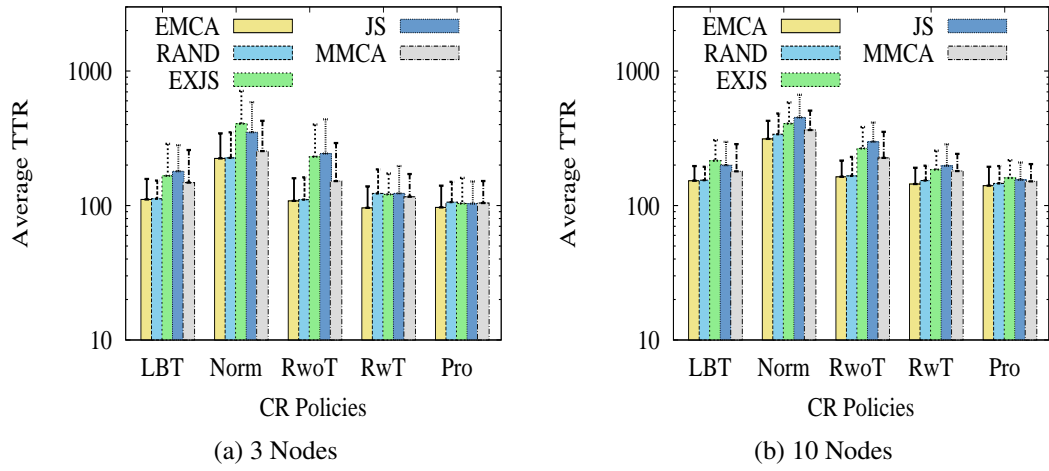

Figure 7.7: Average TTR for multihop (7 ch, 10 BL TSs and High PR activity).

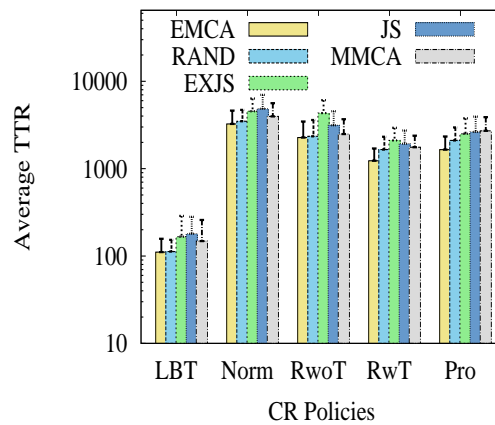

Figure 7.8: Average TTR (3 nodes, 7 ch, 600 BL TSs and High PR activity).

Table 7.1: Average TTR for multihop (3 nodes and 3 BL timeslots)

		7 channels						14 channels					
		ZERO	LOW	LONG	HIGH	INTER	MIXPR	ZERO	LOW	LONG	HIGH	INTER	MIXPR
EMCA	No	54.91	56.44	75.70	110.90	63.91	66.27	69.62	75.56	110.79	166.00	85.00	87.40
	Norm	55.25	61.87	83.94	157.87	83.42	73.31	69.77	80.37	126.13	260.22	111.48	102.16
	RwoT	54.61	52.40	49.09	57.14	53.14	49.28	69.82	69.57	53.71	54.85	67.02	60.68
	RwT	53.76	50.59	46.18	55.21	53.66	49.88	70.05	64.11	53.54	52.94	64.78	60.09
	Pro	54.76	50.40	46.83	52.82	52.34	51.26	70.59	66.49	56.52	51.91	63.65	64.89
RAND	No	56.30	58.29	77.52	112.36	64.58	67.60	72.33	78.19	112.79	169.11	90.27	94.57
	Norm	57.24	63.37	86.64	160.13	84.12	75.18	71.72	84.76	129.06	264.14	115.68	105.59
	RwoT	56.83	53.92	50.12	60.86	55.12	50.40	71.54	70.35	54.36	55.16	68.16	62.00
	RwT	54.97	51.11	48.55	61.62	54.67	51.32	71.45	66.61	54.48	54.87	66.13	60.51
	Pro	56.09	54.07	48.76	55.33	53.70	53.99	72.39	70.91	61.55	54.69	68.10	69.56
JS	No	80.07	81.59	120.87	179.79	86.85	95.22	92.21	104.29	128.92	201.22	119.84	118.78
	Norm	80.33	84.09	124.46	283.07	116.18	119.44	92.58	117.74	166.10	345.11	153.53	135.56
	RwoT	80.84	70.27	102.20	143.17	116.26	94.04	93.17	106.77	153.93	231.54	154.10	122.26
	RwT	75.83	54.62	53.51	66.89	56.16	57.11	94.63	72.72	59.19	58.22	69.77	66.01
	Pro	80.57	56.50	50.17	57.17	54.81	57.55	93.31	76.70	60.24	54.34	67.28	72.03
MMCA	No	83.06	84.40	95.18	148.09	84.71	101.33	110.65	118.88	133.80	221.16	136.30	134.96
	Norm	83.36	86.23	105.05	195.86	110.42	110.06	110.05	128.61	178.98	337.24	165.92	137.27
	RwoT	83.61	76.38	73.23	90.29	84.97	104.16	110.33	113.77	108.98	121.74	101.68	91.52
	RwT	83.04	60.22	56.73	70.92	59.27	62.11	108.93	74.94	63.05	62.14	73.85	83.80
	Pro	83.11	57.50	49.54	57.20	53.97	73.00	110.85	69.30	60.31	56.17	67.09	90.65
EXJS	No	73.60	82.58	121.80	166.20	103.26	96.45	97.01	108.60	154.83	224.16	120.64	130.82
	Norm	74.01	95.90	145.08	273.98	136.40	136.97	97.58	109.29	182.87	367.34	183.74	159.25
	RwoT	74.97	82.00	90.15	172.62	95.34	90.89	97.37	115.97	169.59	289.15	164.23	154.63
	RwT	71.57	54.79	53.79	67.35	55.73	56.42	98.89	70.94	58.33	61.07	71.32	68.36
	Pro	74.95	59.30	50.07	58.01	54.56	59.58	97.27	79.36	64.11	53.66	68.27	78.76

Table 7.2: Average TTR for multihop (10 nodes and 3 BL timeslots)

		7 channels						14 channels					
		ZERO	LOW	LONG	HIGH	INTER	MIXPR	ZERO	LOW	LONG	HIGH	INTER	MIXPR
EMCA	No	66.60	72.72	102.60	152.88	82.16	84.29	91.82	104.66	150.53	232.72	118.22	124.02
	Norm	66.79	79.23	116.17	222.39	113.33	98.82	92.31	109.95	178.71	355.59	162.28	140.72
	RwoT	66.86	61.08	57.55	76.85	66.58	58.96	90.66	90.03	67.60	69.16	83.14	73.69
	RwT	66.85	61.16	55.10	67.97	61.79	56.28	92.68	83.66	63.47	63.76	80.36	73.25
	Pro	66.82	63.37	55.47	66.76	61.75	64.10	92.52	87.24	70.16	61.88	81.63	81.78
RAND	No	67.80	74.06	103.87	154.36	83.77	88.66	93.44	110.62	154.75	236.14	120.38	125.56
	Norm	67.62	80.90	122.39	255.13	119.56	100.68	95.67	112.31	182.69	362.91	167.51	144.68
	RwoT	67.14	62.20	58.45	78.23	67.13	60.15	94.35	91.49	68.18	70.45	84.09	75.45
	RwT	66.83	61.46	56.22	75.74	64.03	58.30	95.87	88.74	65.49	68.35	82.16	75.74
	Pro	67.00	64.47	57.01	70.11	63.37	67.09	96.83	89.69	73.14	64.63	89.17	86.41
JS	No	97.17	104.16	134.08	199.28	113.45	115.86	131.14	132.56	203.49	301.42	149.57	169.38
	Norm	98.33	106.40	163.28	348.85	155.86	134.59	131.94	153.31	270.60	434.43	224.80	201.60
	RwoT	96.18	97.19	116.01	194.01	124.34	136.94	129.70	142.85	195.88	332.36	187.91	172.66
	RwT	94.17	75.60	65.79	94.01	74.08	74.00	126.64	98.80	77.39	75.84	88.28	94.14
	Pro	94.37	75.92	64.42	72.07	65.41	83.04	124.04	98.65	76.89	65.31	90.64	104.55
MMCA	No	93.00	94.86	123.13	179.61	94.40	134.96	137.59	144.11	209.02	290.14	156.31	190.30
	Norm	93.83	99.37	155.34	279.44	136.96	132.37	137.77	147.50	221.46	411.22	190.20	210.27
	RwoT	93.09	89.84	93.91	121.68	84.76	86.75	138.36	119.48	92.74	112.29	130.80	112.94
	RwT	91.09	78.59	78.82	94.30	75.53	72.90	143.12	95.29	80.05	77.80	92.22	94.77
	Pro	92.19	70.15	58.97	71.97	65.36	79.56	138.22	95.50	73.04	64.67	87.64	90.71
EXJS	No	104.48	111.30	152.98	215.56	131.70	126.57	148.89	152.01	249.28	319.24	175.19	182.77
	Norm	103.63	124.81	176.02	351.68	163.60	154.46	148.52	173.54	261.78	456.16	251.18	225.45
	RwoT	103.84	118.77	126.95	195.80	139.25	125.95	146.44	160.89	207.87	340.58	214.04	192.87
	RwT	104.32	78.17	63.59	90.54	70.82	68.66	149.40	97.69	73.89	78.52	86.81	97.09
	Pro	104.29	80.00	61.68	71.77	66.13	89.13	146.61	107.78	88.96	66.34	90.25	126.70

7.6.1.2 Discussion

Overall, with increase in the PR activity, the LBT and Normal policies takes longer time to achieve rendezvous, due to staying silent on PR detected channels. However, the Reactive and Proactive polices are found to be helpful in bringing down the time to rendezvous, which is due to the immediate search of a free channel. The EMCA and Random appear as performing better than the other multihop rendezvous strategies. The Reactive and Proactive also observed as an adaptive strategies, which brings down the time to rendezvous, even in the worst case (i.e., under High PR activity). However, with the increase in the blacklisting time, the time to rendezvous increases as well, but not when the reactive and proactive polices are used.

7.6.2 Average Harmful Interference

The average number of incidents of harmful interference (i.e., when CR transmission coincide with PR activity) are shown in Figures 7.9 to 7.13 for the same experiments shown in Figures 7.3 to 7.8 for the average time to rendezvous both for 3 and 10 nodes. For Zero PR activity, no harmful interference is observed, as there is no PR activity. However, when PR activity is increased, the harmful interference is observed. Only the High and Mix PR activities are discussed here. The remaining graphs and Tables are shown in Appendix A and B.

7.6.2.1 Key observations

The key observations for the harmful interference are as below,

Comparison with single hop case:

- The average harmful interference is found to be slightly higher for 10 nodes, compared to the single-hop case (Chapter 6), due to the increased time to rendezvous.

Different CR operating policies:

- The higher incidents are observed for LBT and Normal policies, but the reactive and proactive policies are found to be helpful in reducing the average number of incidents, due to the lower TTR values, as shown in Figures 7.9 and 7.10.

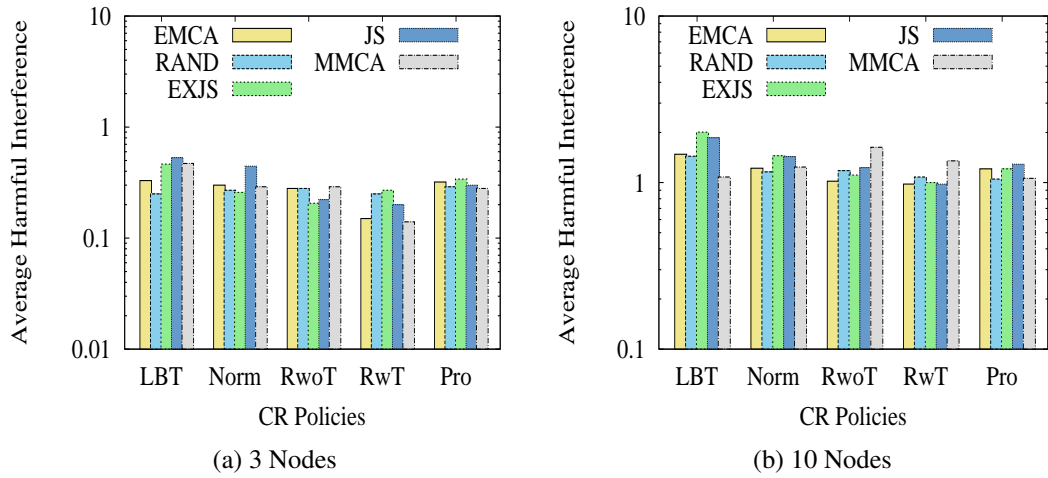

Figure 7.9: Average HI for multihop (7 ch, 3 BL TSs and High PR activity).

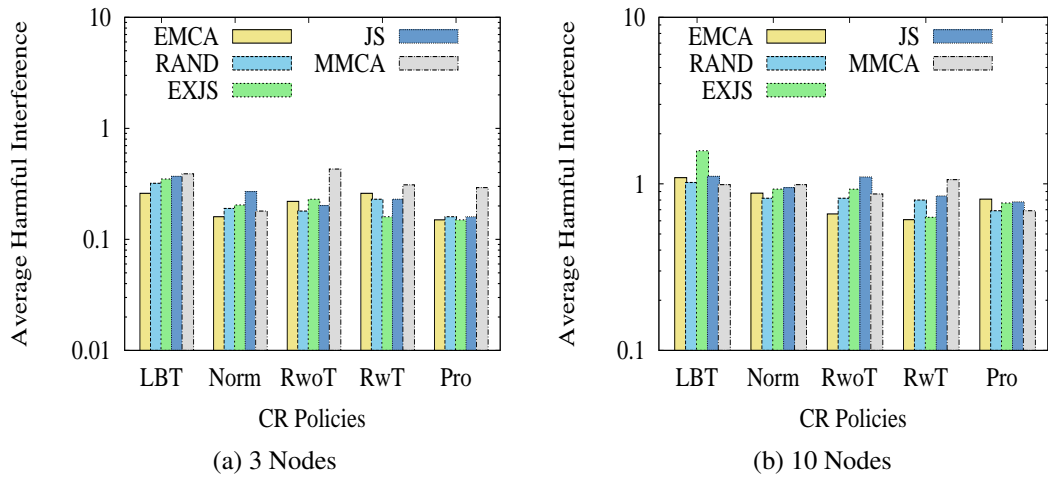

Figure 7.10: Average HI for multihop (7 ch, 3 BL TSs and Mix PR activity).

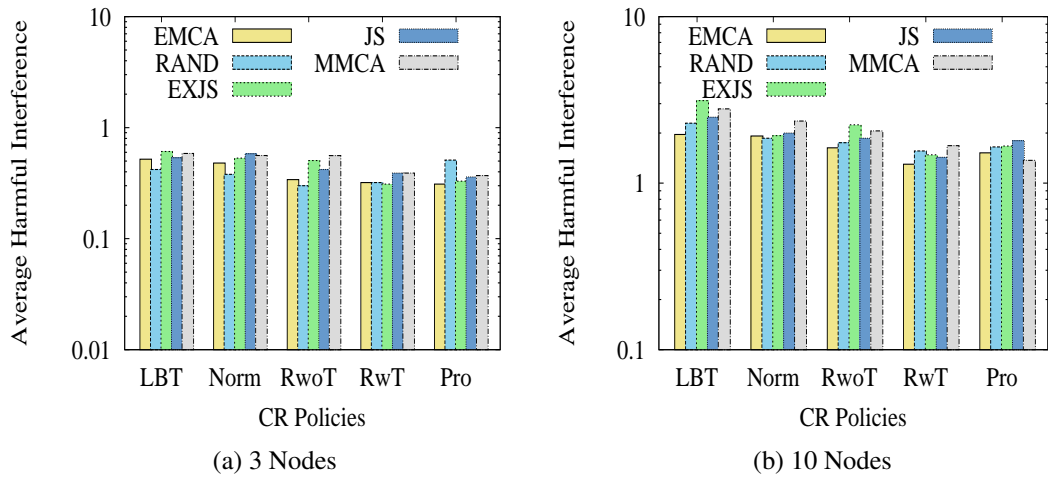

Figure 7.11: Average HI for multihop (14 ch, 3 BL TSs and High PR activity).

Different rendezvous protocols:

- The average HI is found to be below 0.5 incidents for 3 nodes and 1 incident on average for 10 nodes (high PR activity), for different multihop rendezvous protocols. The MMCA, JS, and EXJS are mostly observed with higher HI values, due to their higher TTR values.

Different PR activity traffic patterns:

- With increasing PR activity the harmful interference also increases. For high PR activity, the HI appears to be higher, as shown in Figure 7.9.
- For Mix PR activity (Figure 7.10a), the number of incidents is observed less than 0.2 incidents on average, due to different PR activities on different channels. For 10 nodes (Figure 7.10b), the number of incidents drops down to less than 1 incident on average, compared to the high PR activity case.

Increasing the number of nodes:

- Mostly, with increase in the number of nodes, higher HI incidents are observed, however the operating policies are found to be helpful again in reducing the number of incidents.

Increasing the number of channels:

- For higher number of channels (i.e., 14), as shown in Figure 7.11, no significant difference is observed for 3 nodes case, compared to 7 channels case. However, a marginal increase is observed for the 10 nodes case.

Increasing the channel blacklisting time (i.e., CNP time):

- The longer channel blacklisting time is mainly intended to reduce the harmful interference. However, only a marginal improvement is observed when the CNP time is increased to 10 timeslots, as shown in Figure 7.7. The average number of incidents for the 3 nodes case are observed below 0.3 and for 10 nodes case on average 1.2 incidents are observed.
- With further increase in the channel blacklisting time to 600 timeslots, as suggested by the IEEE 802.22 and shown in Figure 7.13, the harmful interference is found to be below 0.1 incidents on average for 3 nodes, however at the cost of significantly higher time to rendezvous.

7.6.2.2 Discussion

Overall, with an increase in the number of nodes and channels, the harmful interference increases. However, when channel blacklisting time increases, the number of incidents decreases also, but at the cost of higher TTR values. The Reactive and Proactive policies appear as helpful in bringing down the number of harmful incidents.

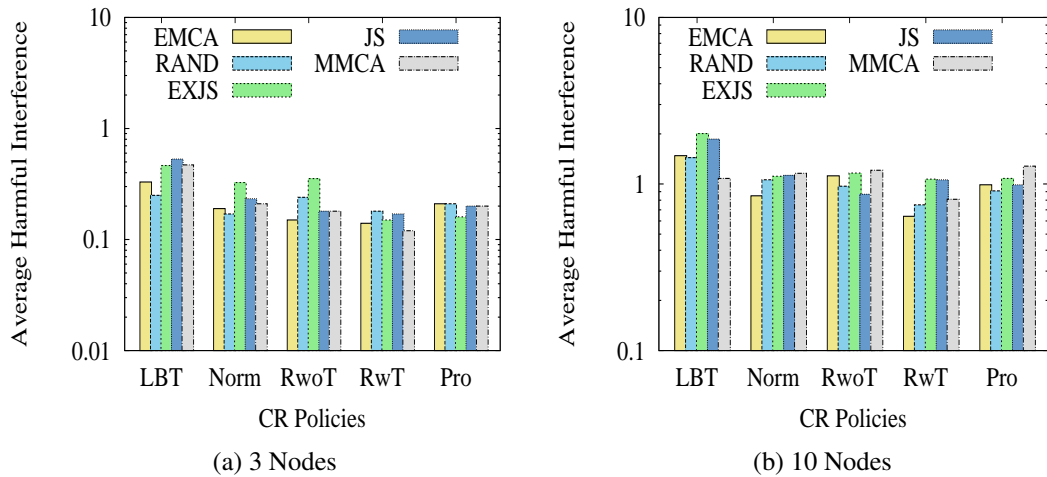

Figure 7.12: Average HI for multihop (7 ch, 10 BL TSs and High PR activity).

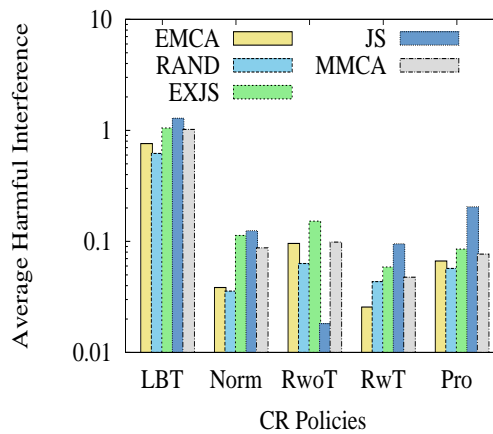

Figure 7.13: Average HI for multihop (3 nodes, 7 ch, 600 BL TSs and High PR).

7.6.3 Neighbour Discovery Accuracy

Neighbour discovery accuracy is the average accuracy of discovered nodes by each node. The multihop rendezvous framework is designed to work in phases and terminates also at some point, with an estimation of the number of nodes. As the nodes are

not aware of the total number of nodes, it is possible that some nodes might not get a chance to discover all its neighbours, due to the unknown PR activity. Therefore, the average neighbour discovery accuracy of different multihop rendezvous protocols is quantified to evaluate the fully blind multihop rendezvous protocols performance. The average neighbour discovery accuracy results are shown in Figures 7.14 to 7.19. Only the last 5% values (i.e., 95 to 100%) are shown in these figures for the clarity.

The key observations are:

- For Zero PR activity, the NDA found to be 100%, as shown in Figure 7.14a (for 3 nodes). However, for 10 nodes case (Figure 7.14b), it drops to only 98%. The drop is because some nodes terminate their rendezvous process earlier without waiting for all nodes to be discovered, and that happens only a few times in 100 simulation runs. The policies do not take part here due to the zero PR activity and therefore the accuracy drops for all the policies is almost same (i.e., about 98%).
- The EMCA and Random protocols appears to be almost 100% accurate in discovering all the nodes, as shown in Figures 7.14, 7.15, and 7.16.
- The MMCA, JS, and EXJS are found to be less accurate than EMCA and Random.
- The Proactive policy is found to be more accurate than the LBT, Normal and RwoT policies in most of the cases.
- For higher number of channels (14 channels), as shown in Figure 7.17 for High PR activity, no significant difference is observed, compared to 7 channels case.
- With the increase in the PR activity to high and when mixed PR activities are used, the accuracy is found to be less only for the 10 nodes case.
- When channel blacklisting time is increased to 10 TSs, as shown in Figure 7.18 (for 7 channels), the neighbour discovery accuracy is observed to be slightly dropped for 3 nodes, because the channels are being blacklisted now for a long time.
- For 10 nodes case, the Normal policy is observed with least NDA of about 97% for MMCA and 98% for EMCA, because it abandons the whole timeslot when PR is detected on a particular channel. However, the Reactive and Proactive policies are observed with almost 100% NDA, for all multihop rendezvous strategies when 10 timeslots CNP time is used.

- For channel blacklisting time as 600 timeslots, as shown in Figure 7.19, the NDA is found to be less for the Normal policy, however, the average NDA improves and reaches above 99% for both the RwT and Proactive policies.

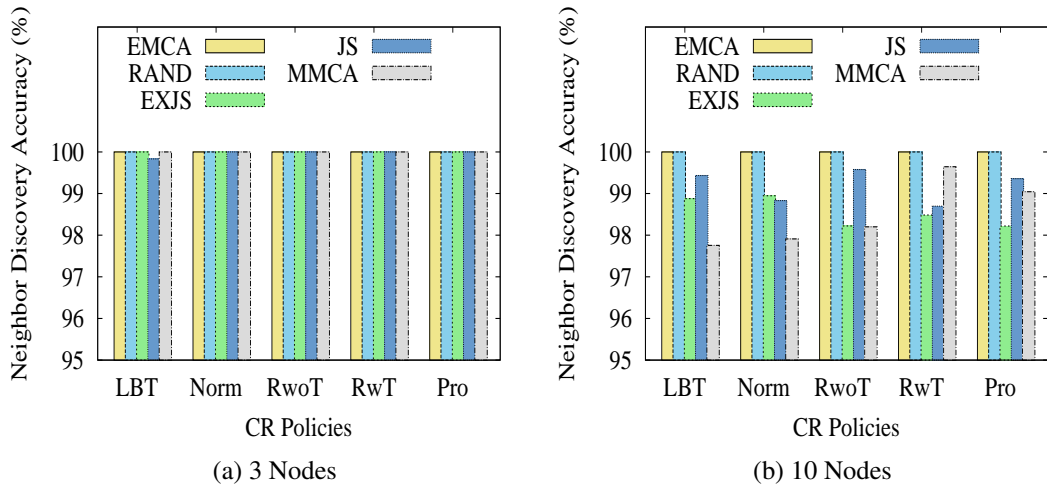

Figure 7.14: Average NDA for multihop (7 ch, 3 BL TSs and Zero PR activity).

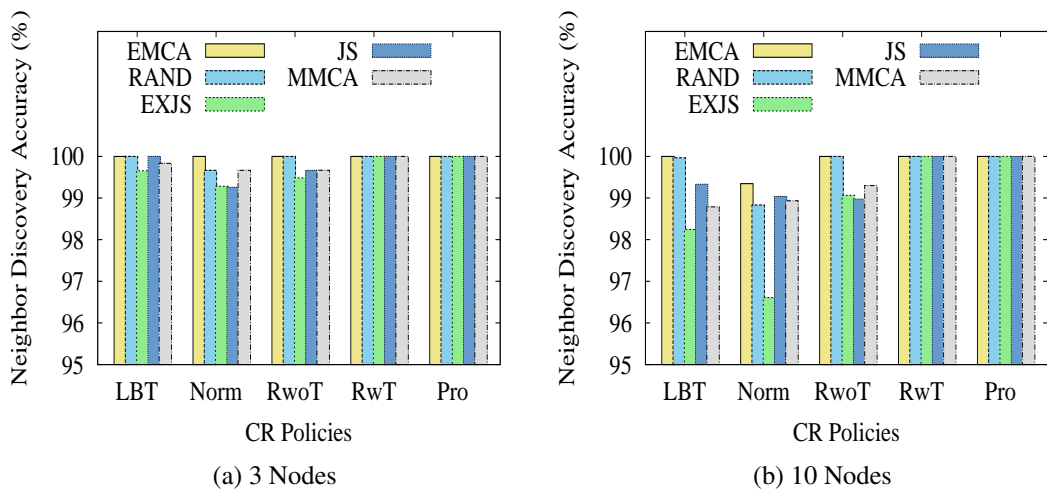

Figure 7.15: Average NDA for multihop (7 ch, 3 BL TSs and High PR activity).

7.6.3.1 Discussion

The EMCA and proactive policy are found to be the best combination, as it achieves mostly 100% accuracy because EMCA completes the rendezvous process on average earlier and proactive returns to the best channel and therefore the neighbour discovery accuracy is almost 100%. The neighbour discovery accuracy decreases with increase in the PR activity and the channel blacklisting time for other protocols, but the operating

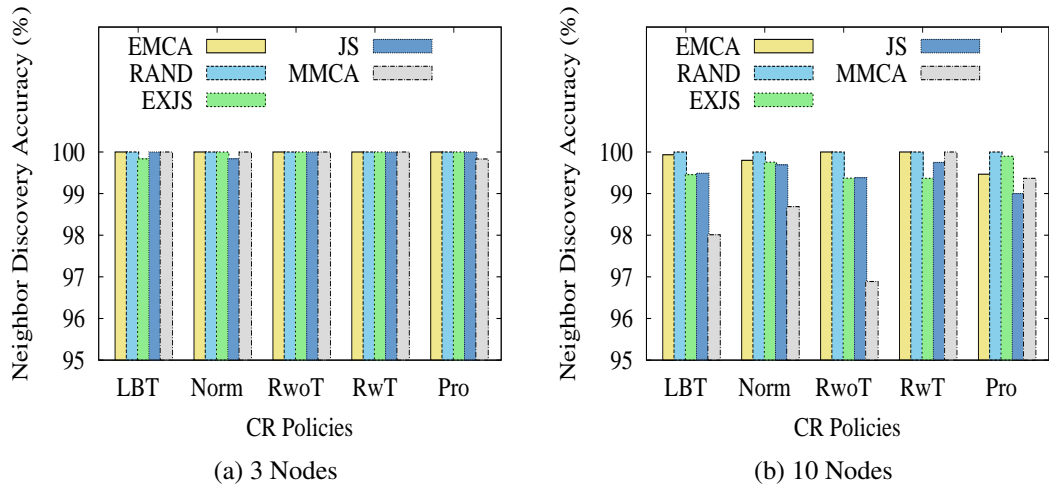

Figure 7.16: Average NDA for multihop (7 ch, 3 BL TSs and Mix PR activity).

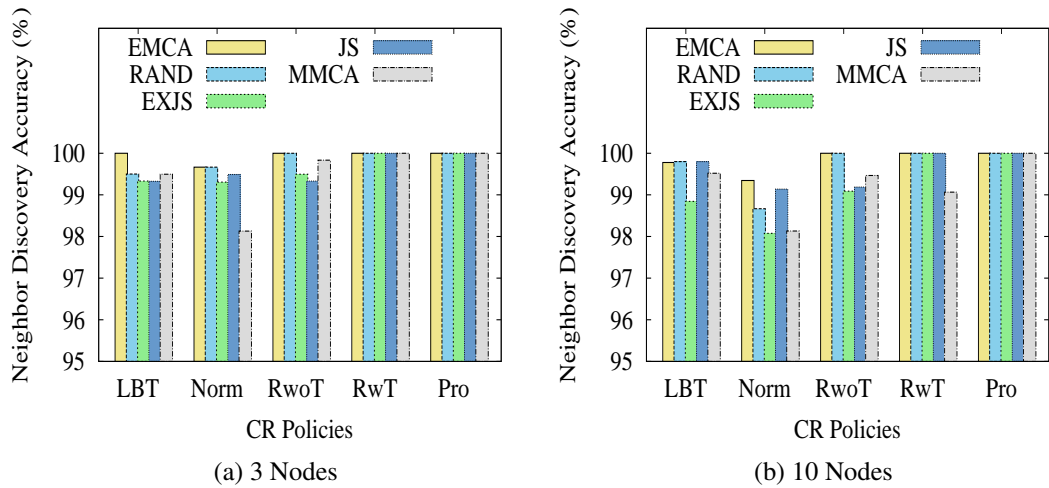

Figure 7.17: Average NDA for multihop (14 ch, 3 BL TSs and High PR activity).

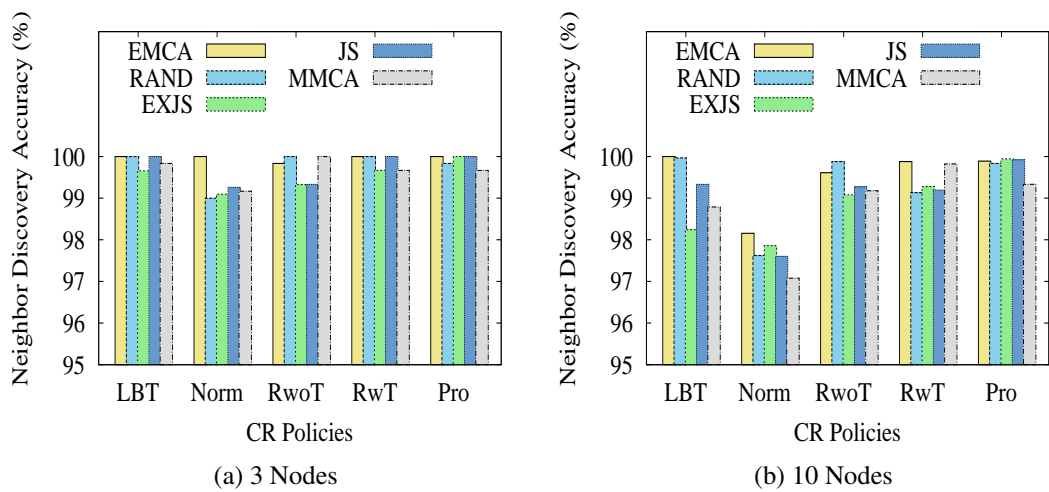

Figure 7.18: Average NDA for multihop (7 ch, 10 BL TSs and High PR activity).

policies are found to be helpful in improving the accuracy. It is possible that due to PR activity, some nodes might not be discovered when the nodes finish their rendezvous process. However, the multihop framework is capable of restarting the rendezvous process from the transition phase, whenever a new node information is found by any node at later stage or even after a rendezvous process has finished.

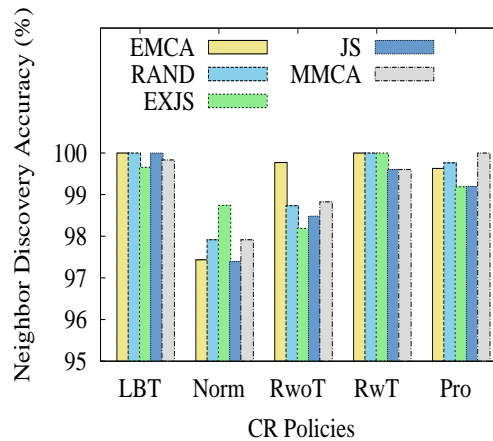

Figure 7.19: Average NDA for multihop (3 nodes, 7 ch, 600 BL TSs, and High PR).

7.6.4 Imperfect sensing

Due to limited sensing capabilities, a radio can also sense in an imperfect way and can claim an occupied channel as an unoccupied and vice versa. To analyse the rendezvous protocols performance, a simulation is performed for 3 nodes under the high PR activity using 3 BL TSs with imperfect sensing, where error probabilities are fixed with 0.1 probability. The results in Figure 7.20 shows only marginal increases in the average time to rendezvous (Figure 7.20a) and the harmful interference (Figure 7.20b). The neighbour discovery accuracy (shown in Figure 7.20c) also appear as less affected as compared to the same experiments with perfect sensing, as shown in Figure 7.15a. The same experiments for perfect sensing are shown in Figures 7.4a (for ATTR) and 7.9a (for harmful interference). When a radio claims an unoccupied channel as occupied, the rendezvous can not be attempted which results in increased time to rendezvous. Similarly, when a radio can not detect a PR activity due to its low signal strength, it attempts a rendezvous by sending a beacon, which results in the increased harmful interference. The LBT and Normal policies when applied result in the increased values of the time to rendezvous and the number of harmful incidents. However, when reactive and proactive policies are applied, these values appears to be almost equivalent to the results under the perfect sensing. The reactive and proactive policies, appear as

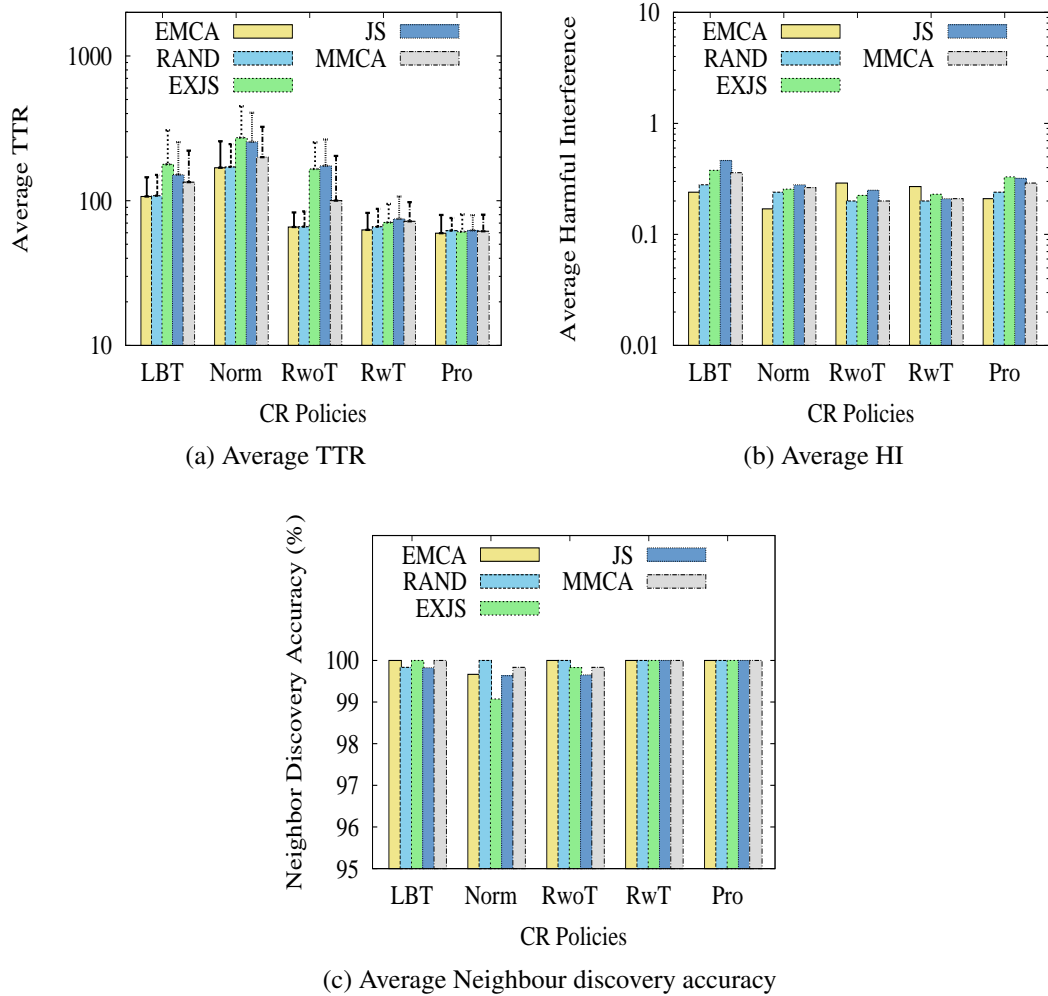

Figure 7.20: Imperfect sensing for multihop (3 nodes, 7 ch, 3 BL TSs and High PR).

beneficial in keeping the TTR and HI values low. EMCA and Random are found to be better than the existing multihop rendezvous strategies. Overall, the imperfect sensing affected the rendezvous performance marginally, but the reactive and proactive policies again found to be helpful in reducing the time to rendezvous and the harmful interference.

7.6.5 Extension of Reactive and Proactive policies

The policies presented in previous Chapter 6, and in this Chapter until now, select a channel only at the start of the timeslot, so that a node stays on a particular channel for a sufficient time. As before (Chapter 6), these policies are extended to work with multihop protocols, by modifying them to select a channel during the timeslot. The reactive and proactive policies are modified to select a new channel even when a PR

appears before a beacon transmission. The performance is analyzed by repeating the experiments for 3 and 10 nodes under High PR activity with 7 channels and 3 BL TSs. The results are shown in Figures 7.21 (for ATTR), 7.22 (for HI) and 7.23 (for NDA). Due to frequent channel selection a node can select a free channel if available to atleast attempt a rendezvous, on the other side it reduces the time for which a node stays on a particular channel to receive a beacon. However, if nodes select the same channel for a time sufficient for a beacon exchange, the rendezvous can occur. The results for the time to rendezvous shows that such extension can further improve the time to rendezvous but only marginally, as shown in Figure 7.21. The percentage improvement for both 3 and 10 nodes appears to be almost 10%, as compared to the policies without extension (Figure 7.4). The LBT and Normal policies are same as before, as they are designed not to change the channel, once selected at the beginning of the timeslot. The harmful interference incidents are not affected much, as shown in Figure 7.22 and compared to Figure 7.9. Similarly, the neighbour discovery accuracy (Figure 7.23) also appear as similar to the previous experiments (without policies extension), shown in Figure 7.15. The modified reactive and proactive policies improves the time to rendezvous but only marginally. However, in terms of the harmful interference and the discovery accuracy, they appear without any significant improvement.

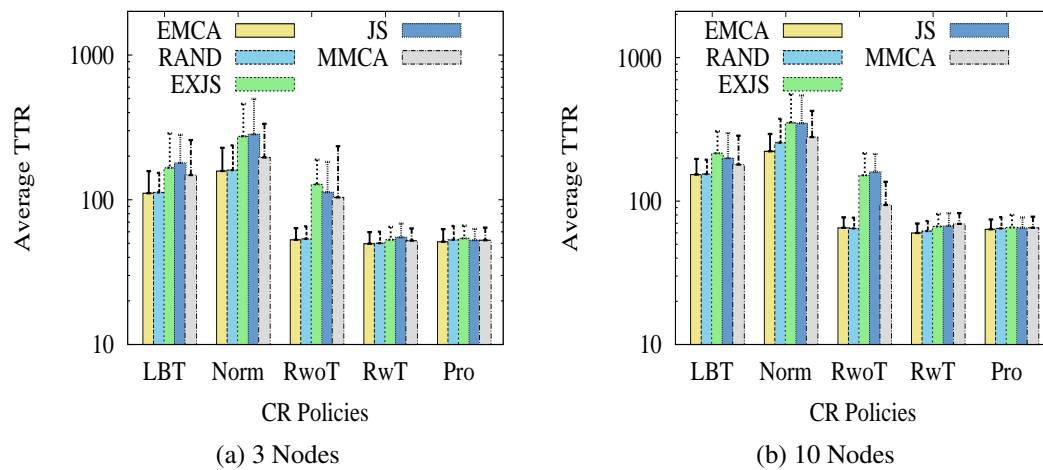

Figure 7.21: ATTR for policies extension (7 ch, 3 BL TSs and High PR activity).

7.6.6 Synchronisation and reachability

The rendezvous is mainly to discover other nodes and to achieve synchronization, when initially the nodes are unaware of their existence and the topology information. Once rendezvous is achieved, the nodes should be able to contact each other, without

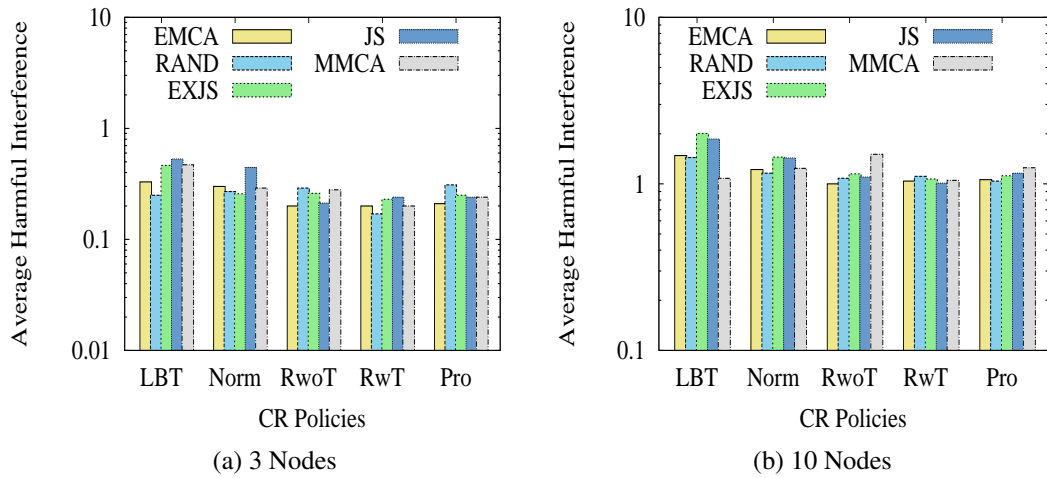

Figure 7.22: Average HI for policies extension (7 ch, 3 BL TSs and High PR activity).

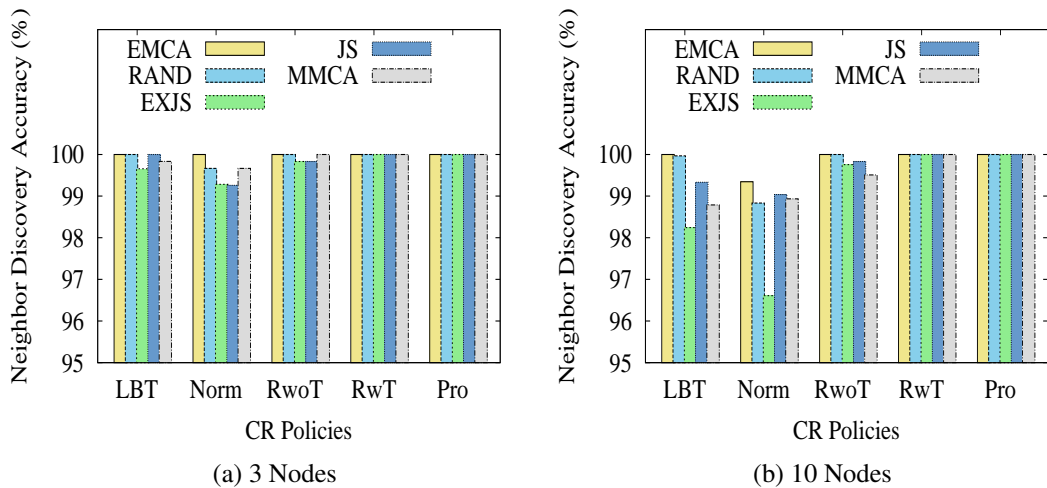

Figure 7.23: Average NDA for policies extension (7 ch, 3 BL TSs and High PR activity).

the need of running again the rendezvous process. We simulate a scenario, in which after completion of a rendezvous process, a randomly selected node sends a message to all its directly connected neighbours at their scheduled time and channels. The node which will receive that message will send an ACK to its sender confirming the reception of the message, and start forwarding the copy of message to their directly connected neighbour, excluding the node from which it has received a message. The nodes are only allowed to forward a message when they will receive it and once all of their one hop neighbours have received a message, they will stop sending it further. The message will be sent only at their scheduled times and channels, otherwise, they will remain quiet. The main objective here is to check, by using those already agreed schedules, the nodes can exchange the messages even after the rendezvous process

has completed. The process runs until last node has received a copy of the forwarded message. Table 7.3 shows the results of the reachability and the time it takes to deliver a message from the randomly selected node to the last node. Throughout the message forwarding process the nodes only tries to reach to those nodes, which are discovered already. The number of nodes are used as 3 and 10 under the zero and high PR activity. The results shown in Table 7.3 for the zero PR activity shows the nodes have achieved a perfect synchronisation among 3 and 10 nodes. However, the delay increases when the number of nodes is increased to 10 nodes, which is because of the gap between the scheduled time among different nodes. When the PR activity is increased to High (85% PR activity), the nodes still can achieve 100% synchronization and can reach to all nodes. However, the delay increases significantly because of the frequent re-schedules among the nodes due to the high PR activity.

Note: Our focus is only on showing the reachability of the nodes and not on improving the performance of a message forwarding scheme under High PR activity.

Table 7.3: Performance of synchronisation and reachability among the discovered neighbours

	Zero PR activity		High PR activity	
	3 Nodes	10 Nodes	3 Nodes	10 Nodes
Reachability (%)	100	100	100	100
Delay (timeslots)	7.44	61.41	120.98	1396.54

7.7 Discussion

In disasters, the environment remains unknown until discovered. The timely discovery of the existing networks, links and nodes is equally crucial to provide the robust and rapidly deployable systems. The proposed multihop rendezvous protocol for cognitive radio based disaster response does not require any prior information of nodes, topology or available links. It is adaptive with the unknown PR activity and can self-organise it self. The proposed protocol even knows when to stops and when to start the algorithm again. It stops when sufficient neighbour information is gathered and can start again whenever any new neighbour arrives within the transmission range of any previously discovered neighbour and can also disseminate such information in the whole network. The neighbour and channel information gathered during this rendezvous phase can be used to achieve synchronisation to establish other network services like data transmis-

sion or routing. This information can be used to establish a multihop backhaul network to connect two sites in a disaster or can be used to establish a standalone multihop mesh network. The rendezvous protocol can be adjusted to run for a long time, in case some nearby base station wants to know who else is out there waiting for the services. So, depending on the application scenario, such timely and reliable information can be used and rendezvous strategy can be adjusted.

7.8 Conclusion

In this Chapter, an EMCA based multihop blind rendezvous protocol is presented for unknown environments. Due to the unknown nodes and topology information, the proposed algorithm works in different phases and estimates the number of nodes. The proposed algorithm can terminate its rendezvous process, when all or most of the nodes are discovered, by a mutual consent which requires to match the neighbour IDs and to be in the Termination phase for the nodes who want to terminate their rendezvous process. To disseminate a complete network view among all the nodes, to establish other network services, a neighbour information mechanism is also presented, which shares the information of its directly and indirectly connected nodes. A scheduling mechanism is also presented for the nodes to meet at an agreed time and channel to establish a synchronisation among different nodes. The proposed multihop rendezvous protocol is evaluated over different cognitive radio operating policies and primary radio activity traffic models with different channel blacklisting times. In terms of the time to rendezvous, the EMCA and Random strategy outperforms all the other multihop rendezvous strategies. The Reactive and Proactive policies are found to be helpful again in bringing down the harmful interference. Overall, the proposed multihop rendezvous strategy provides almost 100% neighbour discovery accuracy. The Proactive policy is found to be the best, as it reduces the time to rendezvous and harmful interference for all rendezvous strategies and also provides 100% neighbour discovery accuracy. The proposed protocol is adaptive with the unknown primary radio activity and can also self-organise by re-initiating the rendezvous process, whenever a new node information is received by any of the already discovered neighbour. It is also shown that the discovered nodes can achieve synchronisation even after finishing the rendezvous process, to establish other network services.

Chapter 8

Conclusions and Future Work

The contributions in this thesis, summarised in this chapter, support our thesis statement:

A cognitive radio based fully blind multihop rendezvous protocol with a reactive or proactive operating policy can achieve multi-node rendezvous in unknown environments in the presence of primary radios, which is sufficient to start establishing network services.

There are several applications and many research papers in the literature for disaster scenarios. However, the key requirements for a disaster response network; potential of a cognitive radio; a solution which satisfies all or most of the identified requirements and provides an effective and timely response; fully blind rendezvous as a deployment challenge which requires no initial information and should work for multihop; cognitive radio operating policies to protect the primary radio users from the harmful interference during a rendezvous process; adaptivity towards unknown primary user activity; and self-organized rendezvous solutions, are not considered until now in the literature in detail. Therefore, this thesis can help in filling these above-mentioned gaps and can help in providing an effective solution for a timely response in the early hours of a disaster.

In this chapter, the conclusion and contributions are highlighted and key developments are shown, followed by a discussion of possible future work.

8.1 Contributions

In this thesis, the following contributions are made in the area of using cognitive radio technology for effective response in disaster situations, and in particular establishing network services with a low network setup time.

1. Key requirements are identified for a disaster response network including QoS, rapid deployment, spectrum agility, robustness and reliability, self-organization, interoperability, and cost-effectiveness. **(Chapter 2)**
2. The existing literature on blind rendezvous strategy is surveyed. Issues and challenges for blind rendezvous are identified, based on which the need of a fully blind rendezvous for unknown environments is identified. **(Chapter 3)**
3. A software-defined radio based multihop cellular base station prototype is proposed, developed and evaluated, for supporting voice communication using the GSM services at front-end and sufficient QoS support at the back-end. It is tested in a lab environment. Parameters like latency and packet losses are evaluated and it is demonstrated that the designed prototype can support up to 50 simultaneous calls with sufficient call quality when the conditions are favorable (i.e., radio environment is quiet). However, in busy environments, the number of supported calls reduced to only a few. It is further concluded that the backhaul link must utilize the spectrum dynamically to ensure the sufficient voice quality for a number of users. It is further discussed that, when such a system is to be placed in an unknown environment, then it can face other deployment challenges amongst which the foremost is to establish rendezvous between different nodes to establish other network services. **(Chapter 4)**
4. An Extended Modular Clock Algorithm (EMCA) is proposed as a blind rendezvous protocol for single hop networks with asymmetric channels and asynchronous timeslots. It abandons the impractical rendezvous guarantee (unlike the existing blind rendezvous strategies) but has a short rendezvous cycle length and rendezvous time. It considers unknown primary user activity and is evaluated over different primary user activity patterns. An information exchange mechanism is also proposed with a handshake mechanism to expedite the rendezvous process and to reduce the time to rendezvous. EMCA is shown to be better in terms of time to rendezvous when compared with existing published blind rendezvous strategies. **(Chapter 5)**
5. Different cognitive radio operating policies are proposed, namely Normal, Re-

active with and without timeslot truncation and Proactive, according to the published requirements of the standards bodies. The impact of applying policies on different rendezvous strategies was unknown until now. The policies are designed as a general framework to improve the performance of all rendezvous strategies. The policies especially the RWT and Proactive policies further improves all the protocols performance in terms of the time to rendezvous and also reduces the harmful interference. These policies are also shown to be better than Listen Before Talk approach by 90% improvement. A scenario with an original policy recommendation is also simulated, which shows a little improvement over the harmful interference but at the cost of longer time to rendezvous. This shows that, if these policies are to be applied for a disaster scenario, they need to be carefully designed by choosing the channel non-occupancy period (CNP). Therefore, the time to rendezvous and harmful interference are analyzed with different CNP times. It is shown that when the CNP time is short, the time to rendezvous is short and the harmful interference is low; however, when CNP time is long, the harmful interference drops further but the time to rendezvous starts increasing. **(Chapter 6)**

6. A more challenging scenario with an unknown number of nodes and topologies is considered for extending over a single hop scenario mentioned above. A general framework for fully blind cooperative multihop rendezvous protocol is proposed for an unknown environment. The proposed protocol works in different phases to complete a rendezvous among different nodes. Other contributions for the multihop protocol are:

- An efficient termination condition is proposed to terminate the algorithm with mutual consent between one-hop neighbours when all or a sufficient number of nodes are discovered.
- A neighbour information exchange mechanism is proposed to disseminate the neighbour information across the network to help achieve termination, share a complete network view and to establish other network services.
- A scheduling and synchronization mechanism is also proposed to help nodes meet at a periodic scheduled point to exchange information.

The proposed protocol is cooperative, in which each node cooperates with its one-hop neighbours to update its rendezvous information. It is also capable of accommodating any new node which enters into the network by disseminating its information to other nodes and any node which leaves the network by updat-

ing again the other nodes in the network, to update a complete network view at each node. The proposed multihop protocol is evaluated over different primary user activity patterns and cognitive radio operating policies over a different number of nodes, channels and CNP times. Since there is no fully blind rendezvous protocol in the literature, the state of the art blind rendezvous strategies are modified with the proposed framework and compare with EMCA. EMCA continues to outperform the others in terms of the time to rendezvous. (**Chapter 7**)

8.2 Thesis summary and recommendations

An extended modular clock algorithm based blind rendezvous protocol is presented in this thesis work with different cognitive radio operating policies and a general framework for a fully blind multihop rendezvous protocol. The fully blind multihop rendezvous protocol framework can be integrated with all existing blind rendezvous strategies, which takes in achieving rendezvous without any node or topology information. The proposed protocol is shown to be adaptive towards the unknown primary user activity and cooperative to achieve rendezvous among all nodes when the topology and number of nodes are unknown with primary user activity and available channels. The proposed protocol is evaluated over different primary user activities and found to be better in comparison with existing blind rendezvous strategies in terms of the time to rendezvous, harmful interference towards the unknown primary user activity and neighbour discovery accuracy. Mainly, it is designed for an unknown environment like disasters, however, it can also be beneficial in achieving the design and performance goals in other networks like D2D communication or other Ad-hoc and distributed networks. The proposed protocol can be adjusted to work according to the application requirement in different networks. It can also achieve synchronization in a shorter time than the other blind rendezvous strategies. EMCA is overall recommended to use in any scenario with symmetric or asymmetric channels and synchronous or asynchronous timeslots settings. In unknown environments, the channels, nodes and topology information might be unavailable initially. Therefore, the nodes can have symmetric or asymmetric channels in their available channels set. EMCA is shown to be better than the existing blind rendezvous strategies under symmetric channels case. It is also found to be better than the other strategies when the channels are asymmetric among the nodes. However, with Random it is found to be only marginally better under asymmetric channels case but on average EMCA is found to be better. The policies overall are also found to be helpful in reducing the time to ren-

deztvous and harmful interference towards the unknown primary user activity, and in achieving almost 100% neighbour discovery accuracy. The proactive policy is found to be better in improving the results for all the existing rendezvous strategies. Most importantly, it can terminate its rendezvous process at each node even when the nodes information is unavailable and can autonomously handle the rendezvous process to manage new neighbour information. Overall, EMCA with proactive operating policy is found to be the best combination to improve the results.

8.3 Future Work

There is still much work to be done before a full cognitive radio deployment for disaster response networks is possible. The main aspects are discussed below,

- The thesis evaluates the proposed rendezvous and operating policies through the use of extensive simulations. Future work can integrate these solutions on a real testbed. In fact, these solutions can be integrated into the prototype to establish a dynamic multihop backhaul network using licensed bands (like TV, cellular, and radar bands). Further, it should be mounted on a mobile robot to perform the service restoration task in a real-world scenario.
- The use of TV White spaces is generating much interest for the use of broadband service. The presented disaster response network prototype should also be extended to work with TV White spaces for extended coverage.
- The blind rendezvous strategy is mainly designed for a single radio on each device. It can be extended to multi radio systems, where one radio can handle the channel sensing and primary user activity, and the other radio can attempt rendezvous on designated channels.
- In this thesis, the radios support only half-duplex communications. In future work, it should be extended to work with full-duplex radios, for which the work is still in its early stages and proper MAC operations still need to be researched.
- More sophisticated learning strategies should be developed for better channel selection. For example, a channel can be selected based on the remaining idle time. However, it is necessary that the learning and decision-making occurs at run-time to reduce the network setup delay.
- The thesis considers only static nodes in the experiments. The impact of mobile nodes should be evaluated.

- The energy efficiency can also be considered as a part of the design goals by optimizing further the nodes messages overhead and transmission schedules.
- The presented blind rendezvous strategy can also be used for a Proximity device discovery for Device-to-Device communication so that the devices can find each other and communicate directly in the absence of a cellular base station or in an emergency situation.

Appendix A

Figures

A.1 Chapter 6

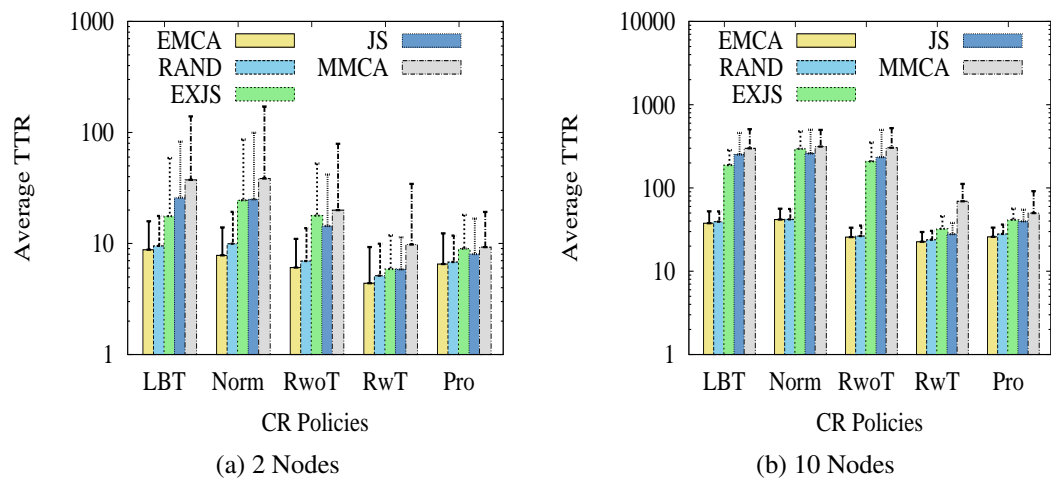

Figure A.1: Average TTR for single-hop (7 ch, 3 BL TSs and Low PR activity).

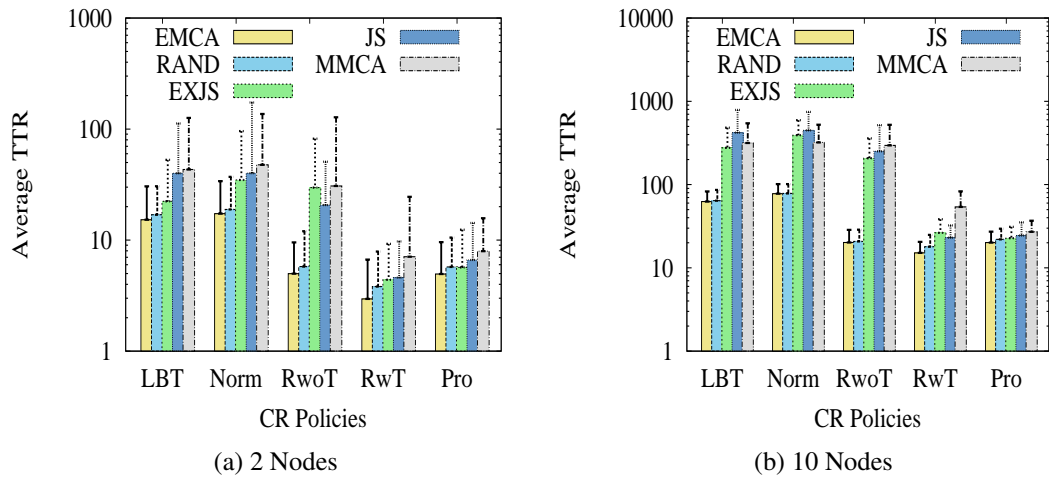

Figure A.2: Average TTR for single-hop (7 ch, 3 BL TSs and Long PR activity).

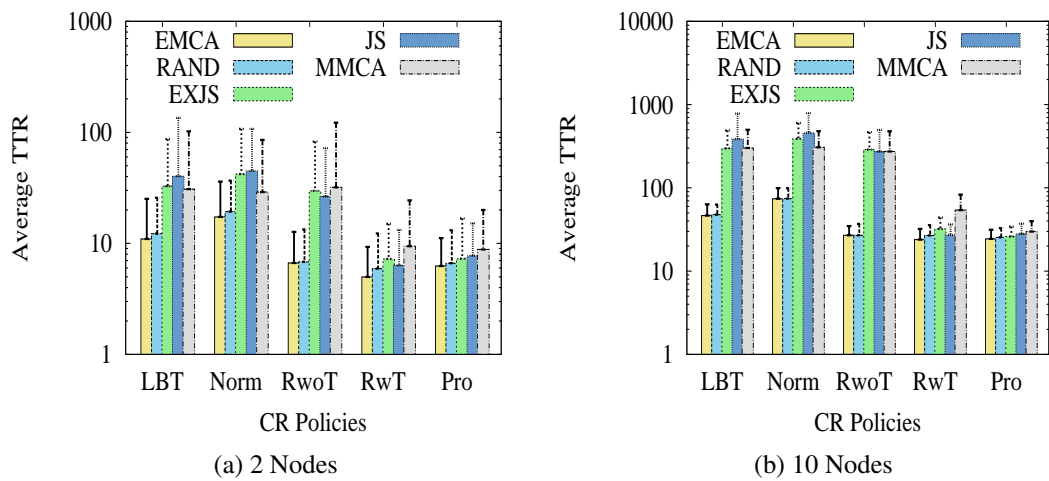

Figure A.3: Avg TTR for single-hop (7 ch, 3 BL TSs and Intermittent PR activity).

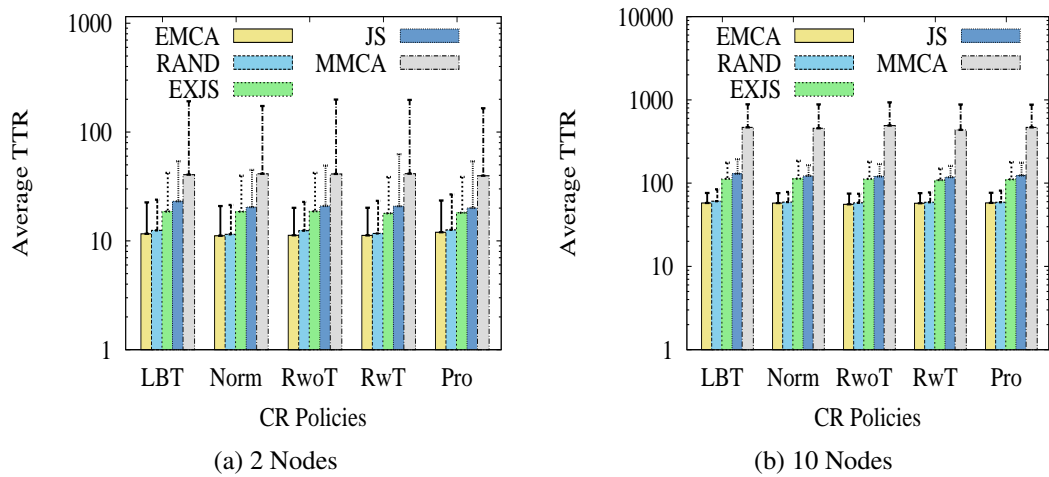

Figure A.4: Average TTR for single-hop (14 ch, 3 BL TSs and Zero PR activity).

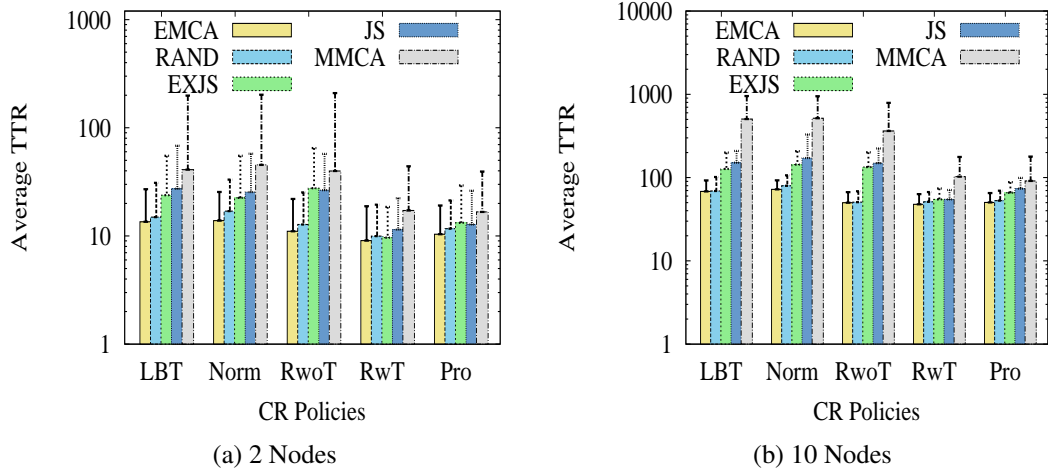

Figure A.5: Average TTR for single-hop (14 ch, 3 BL TSs and Low PR activity).

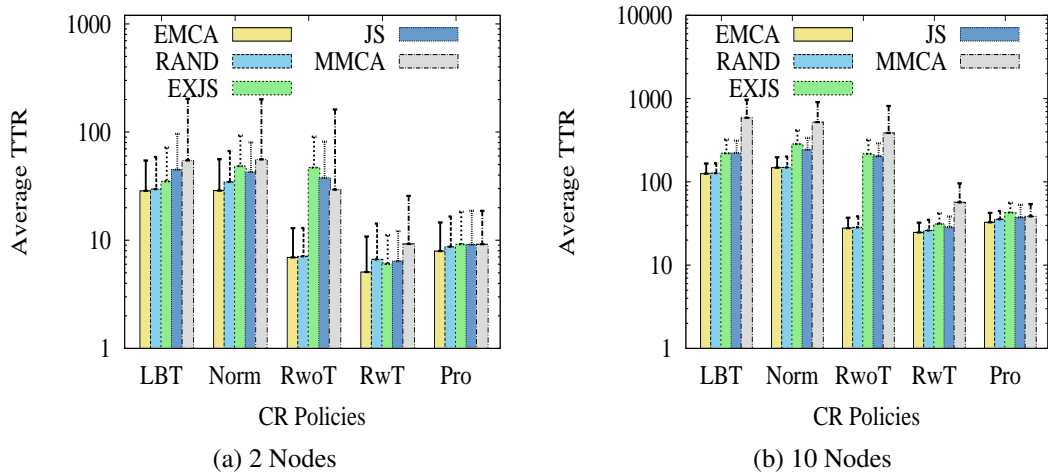

Figure A.6: Average TTR for single-hop (14 ch, 3 BL TSs and Long PR activity).

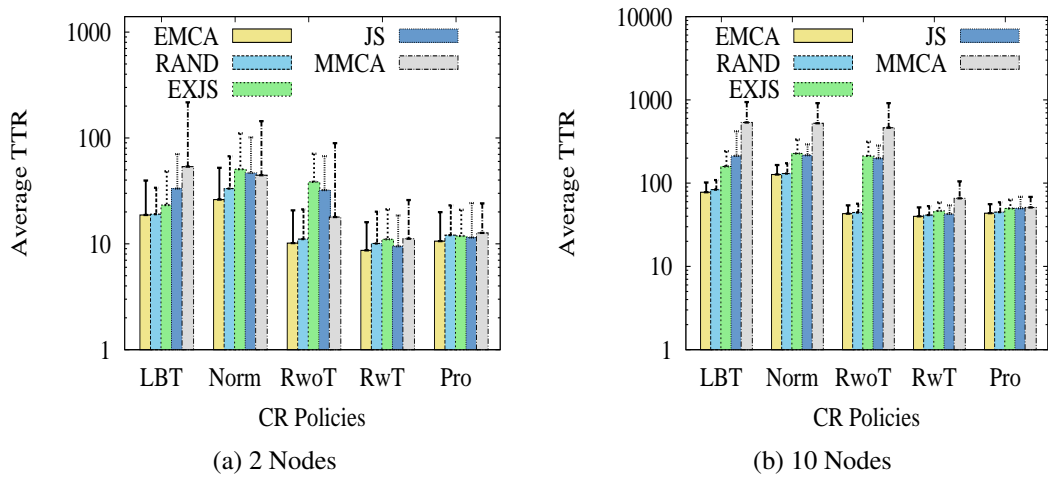

Figure A.7: Avg TTR for single-hop (14 ch, 3 BL TSs and Intermittent PR activity).

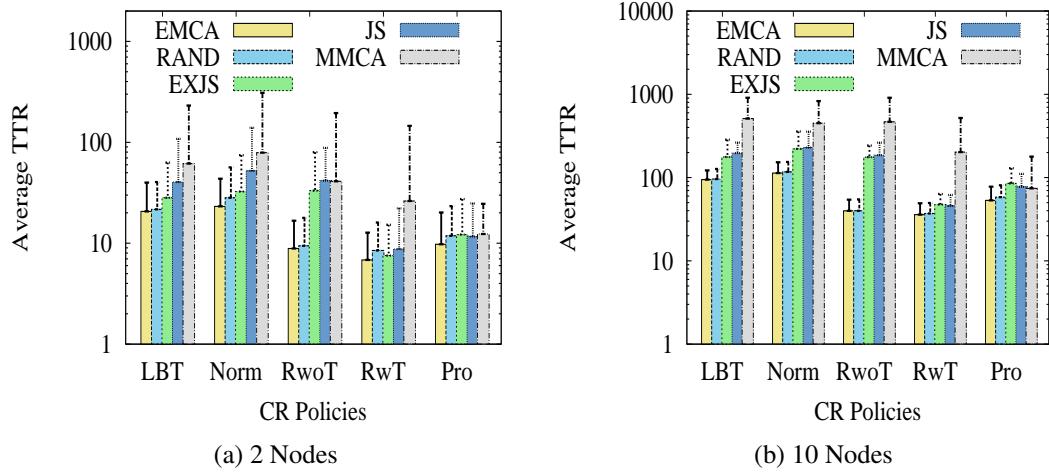

Figure A.8: Average TTR for single-hop (14 ch, 3 BL TSs and Mix PR activity).

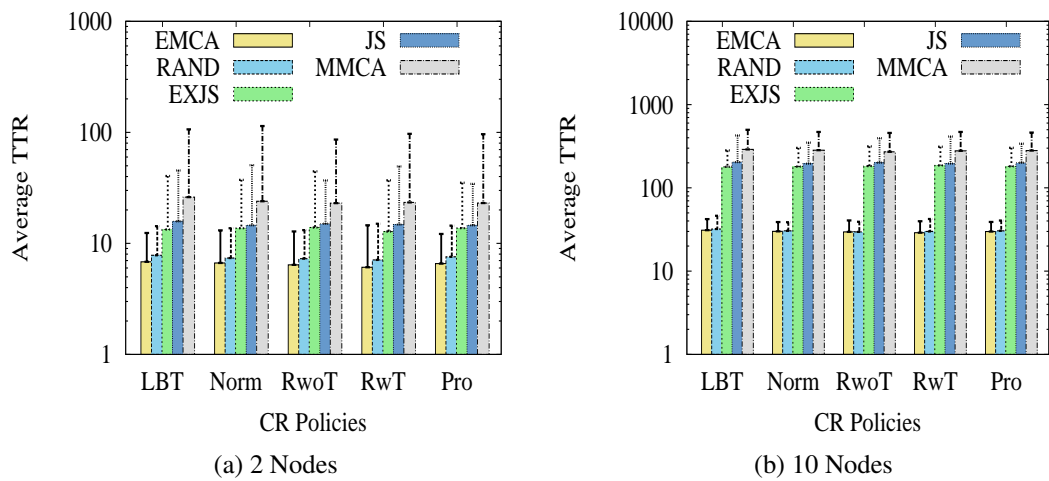

Figure A.9: Average TTR for single-hop (7 ch, 10 BL TSs and Zero PR activity).

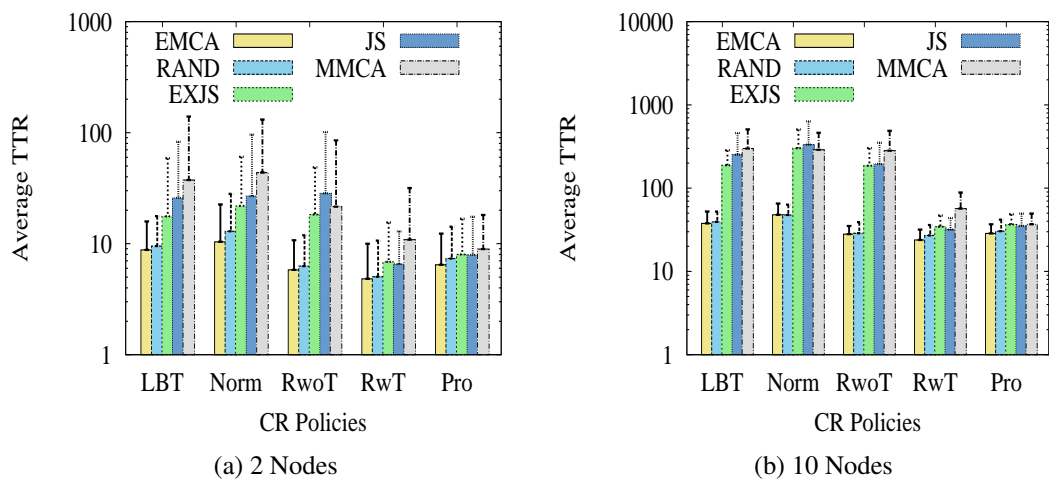

Figure A.10: Average TTR for single-hop (7 ch, 10 BL TSs and Low PR activity).

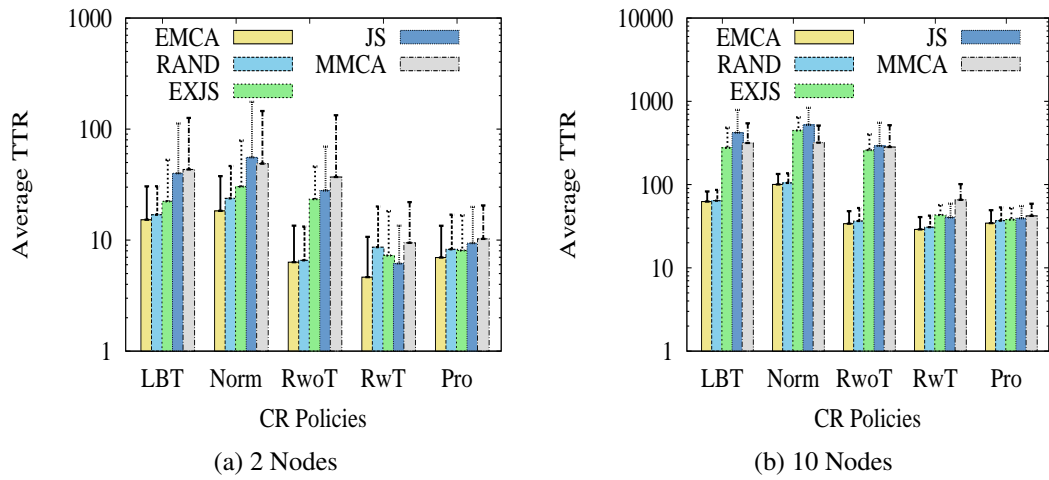

Figure A.11: Average TTR for single-hop (7 ch, 10 BL TSs and Long PR activity).

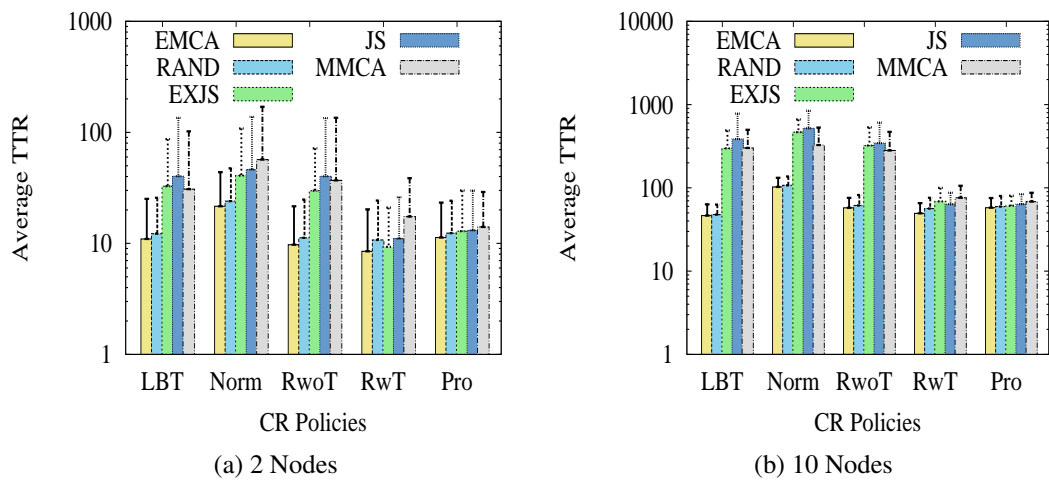

Figure A.12: Avg TTR for single-hop (7 ch, 10 BL TSs and Intermittent PR activity).

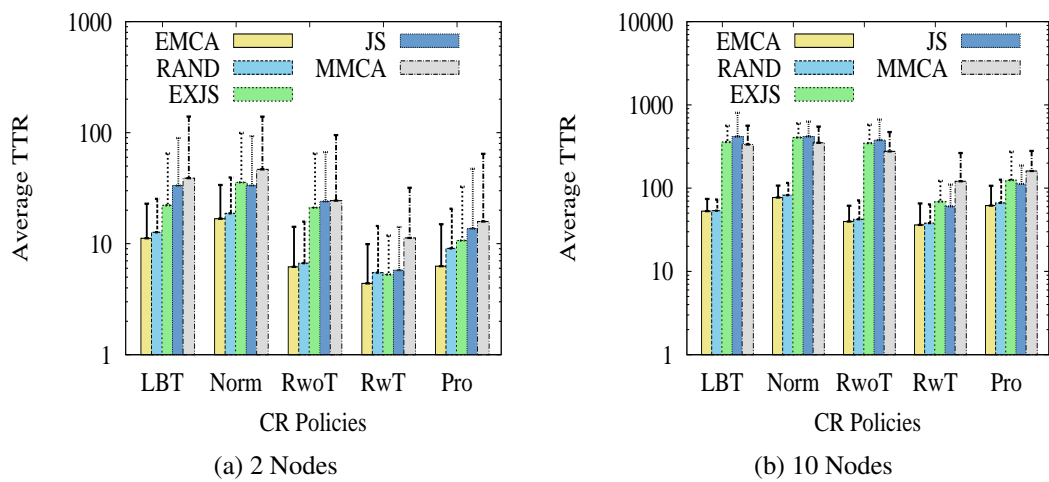

Figure A.13: Average TTR for single-hop (7 ch, 10 BL TSs and Mix PR activity).

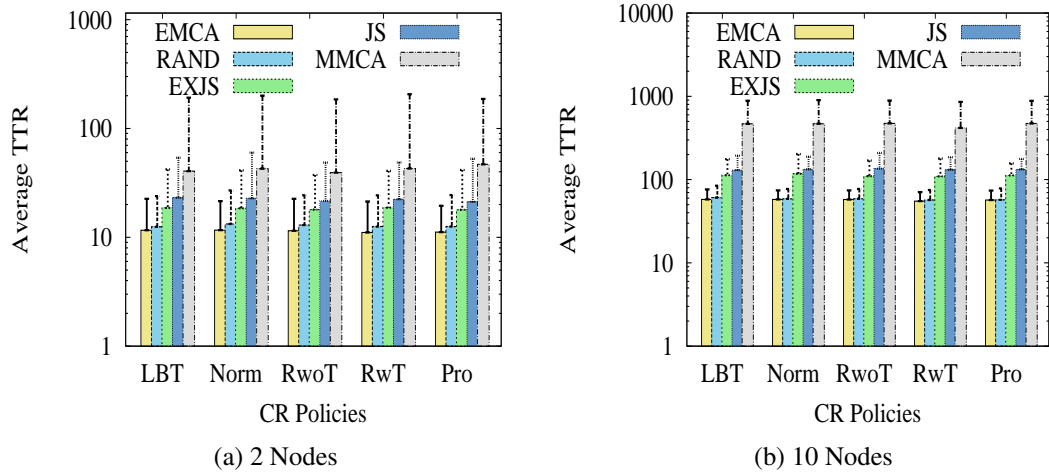

Figure A.14: Average TTR for single-hop (14 ch, 10 BL TSs and Zero PR activity).

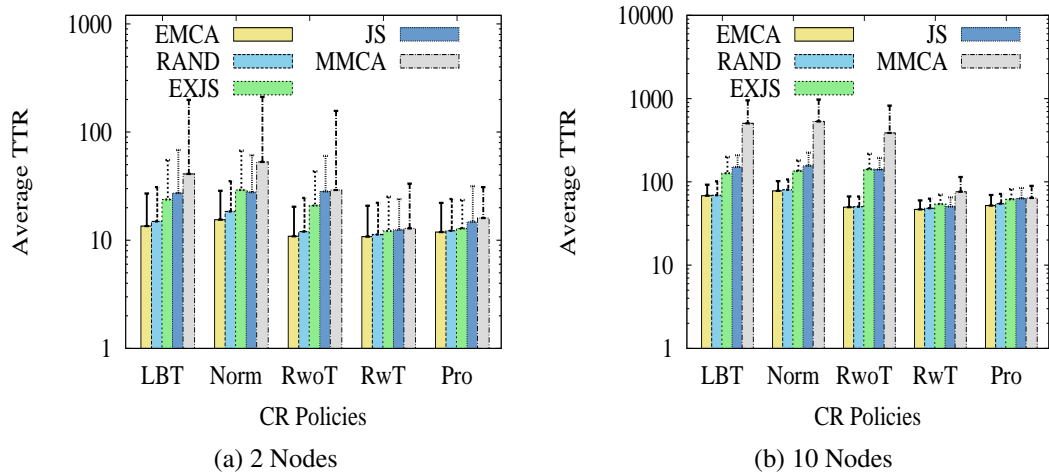

Figure A.15: Average TTR for single-hop (14 ch, 10 BL TSs and Low PR activity).

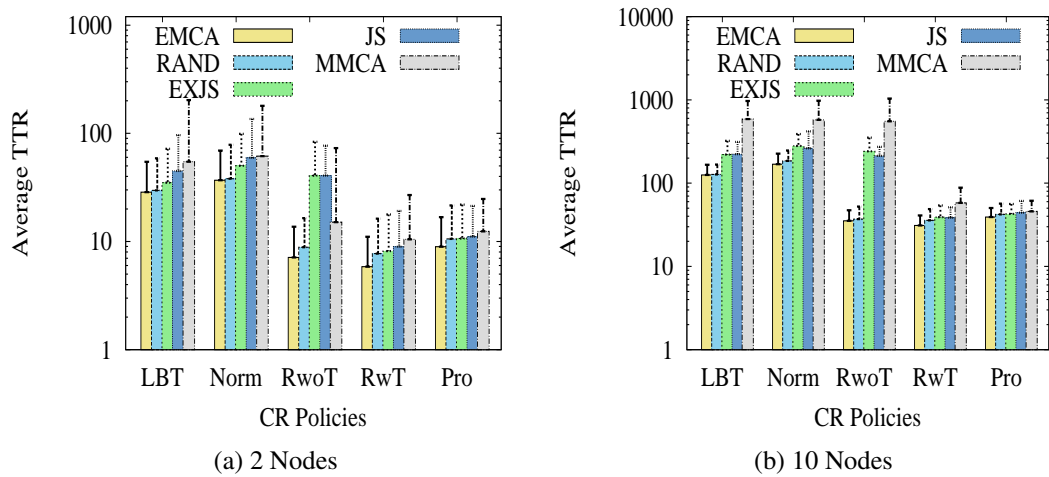

Figure A.16: Average TTR for single-hop (14 ch, 10 BL TSs and Long PR activity).

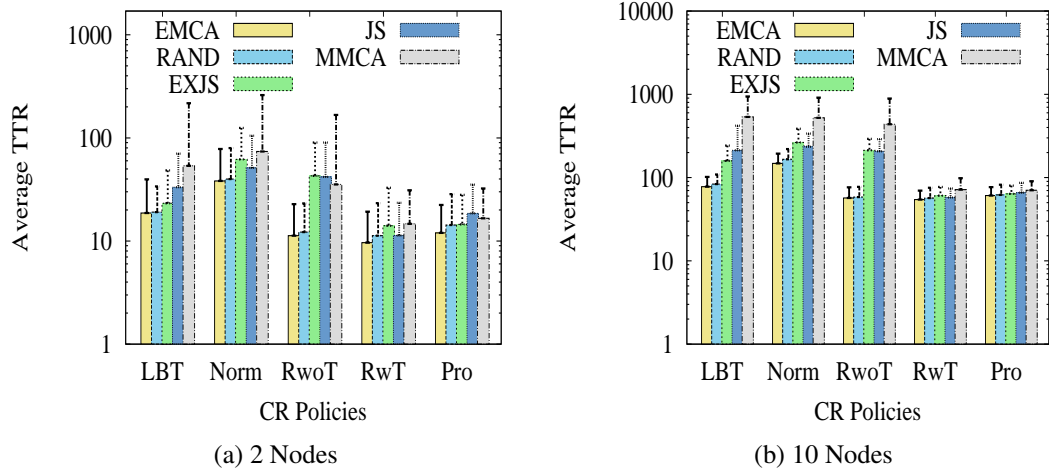

Figure A.17: Avg TTR for single-hop (14 ch, 10 BL TSs and Intermittent PR activity).

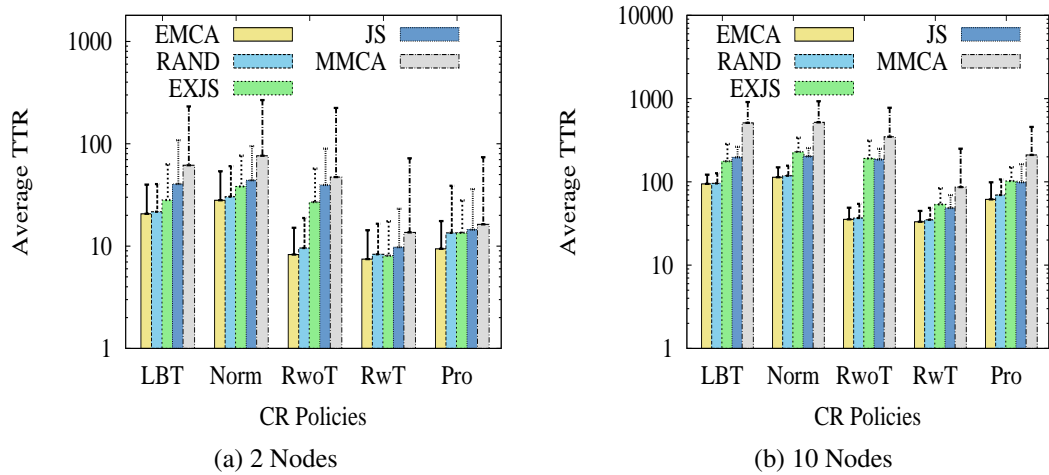

Figure A.18: Average TTR for single-hop (14 ch, 10 BL TSs and Mix PR activity).

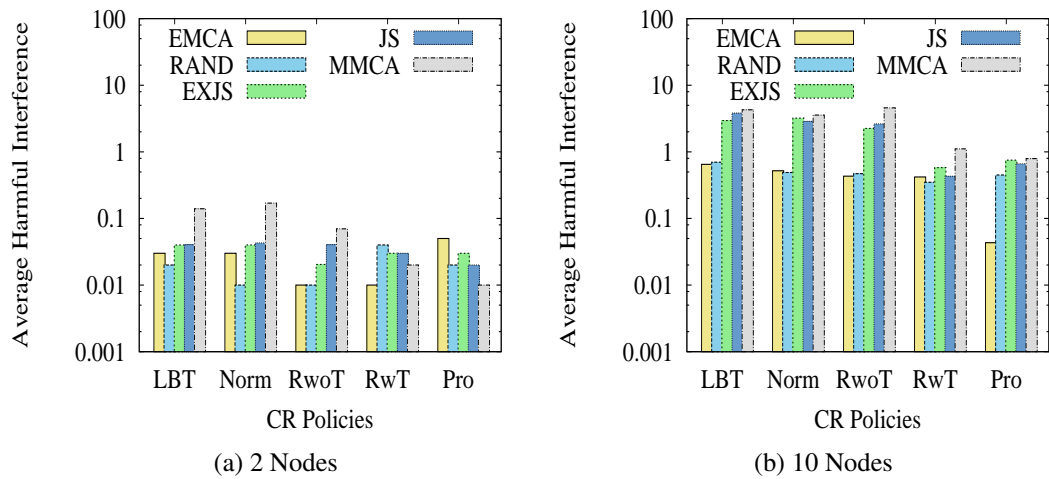

Figure A.19: Average HI for single-hop (7 ch, 3 BL TSs and Low PR activity).

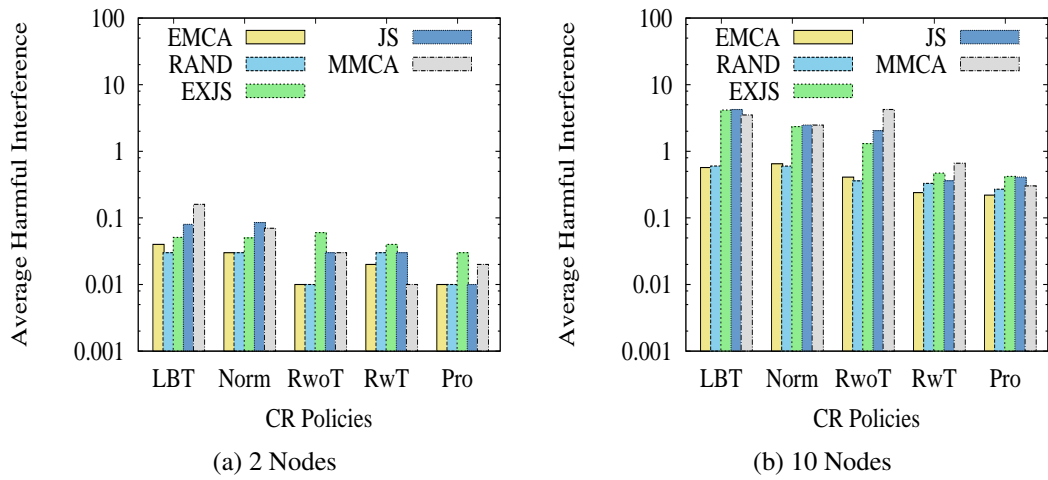

Figure A.20: Average HI for single-hop (7 ch, 3 BL TSs and Long PR activity).

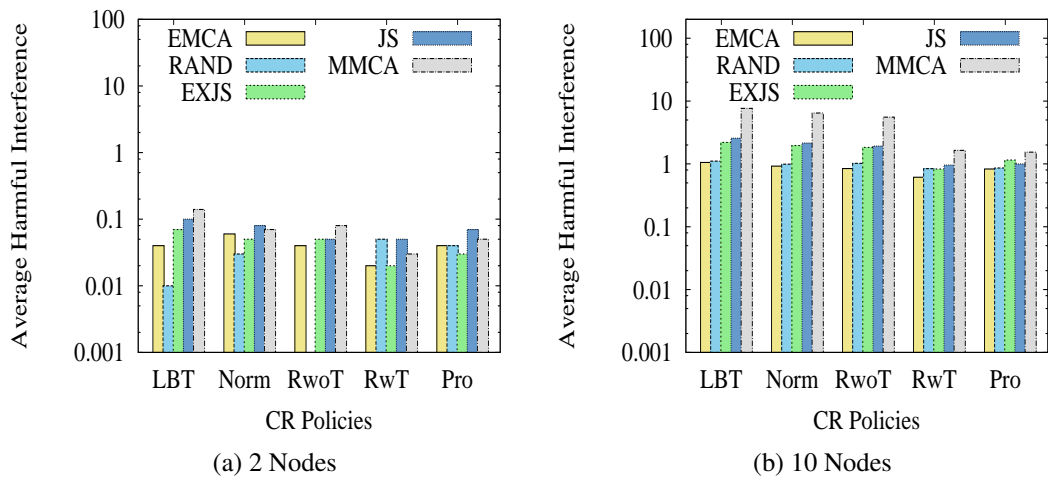

Figure A.21: Average HI for single-hop (14 ch, 3 BL TSs and Low PR activity).

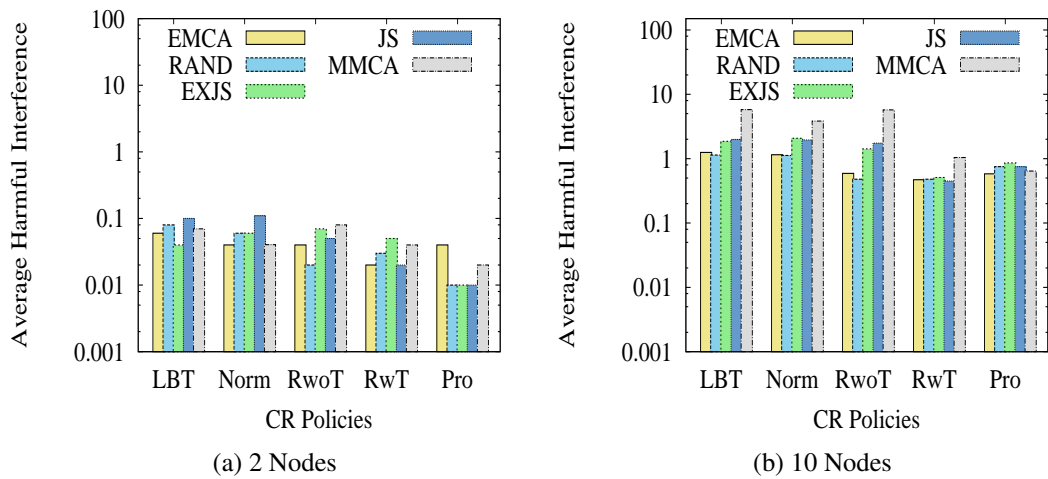

Figure A.22: Average HI for single-hop (14 ch, 3 BL TSs and Long PR activity).

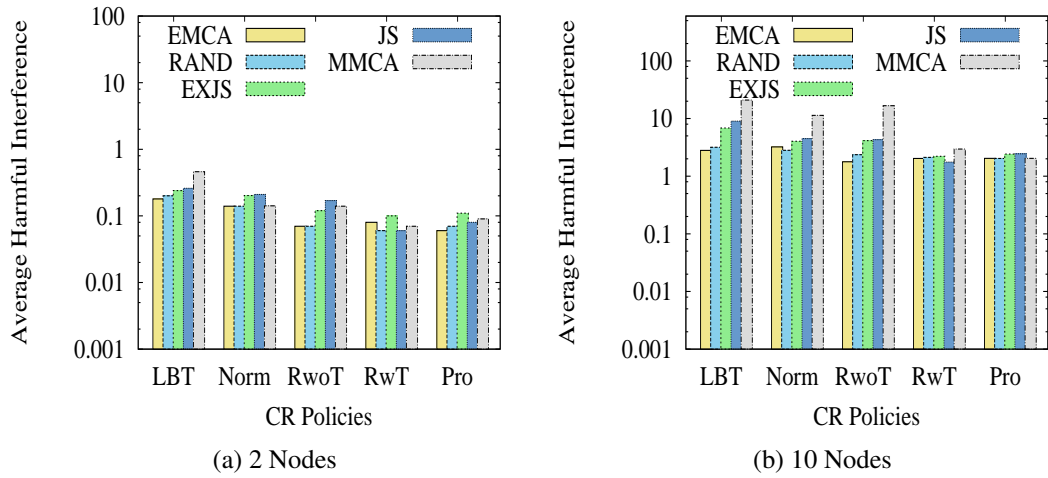

Figure A.23: Avg HI for single-hop (14 ch, 3 BL TSs and Intermittent PR activity).

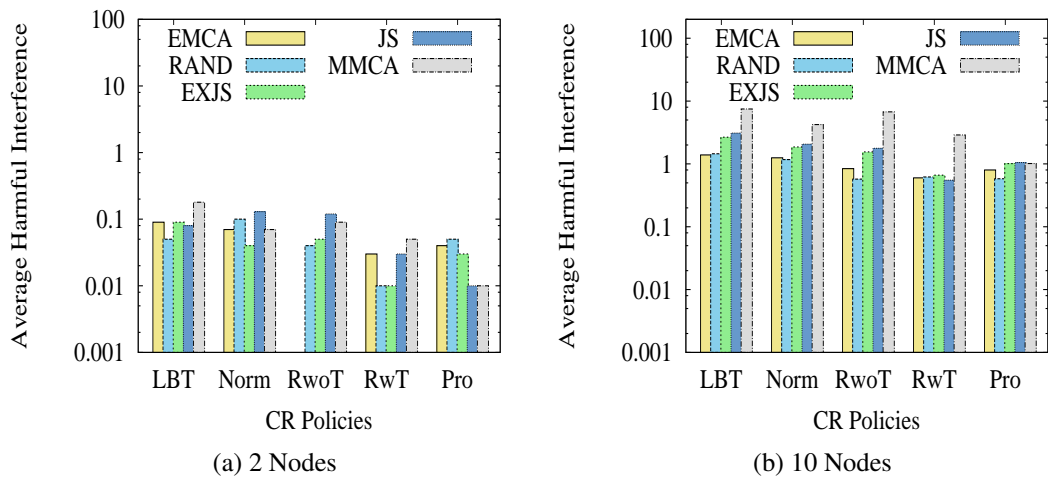

Figure A.24: Average HI for single-hop (14 ch, 3 BL TSs and Mix PR activity).

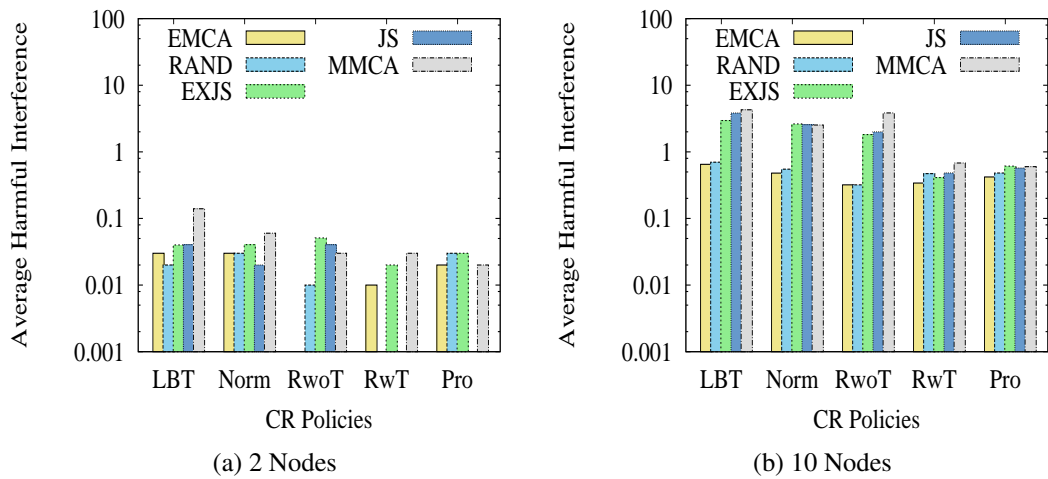

Figure A.25: Average HI for single-hop (7 ch, 10 BL TSs and Low PR activity).

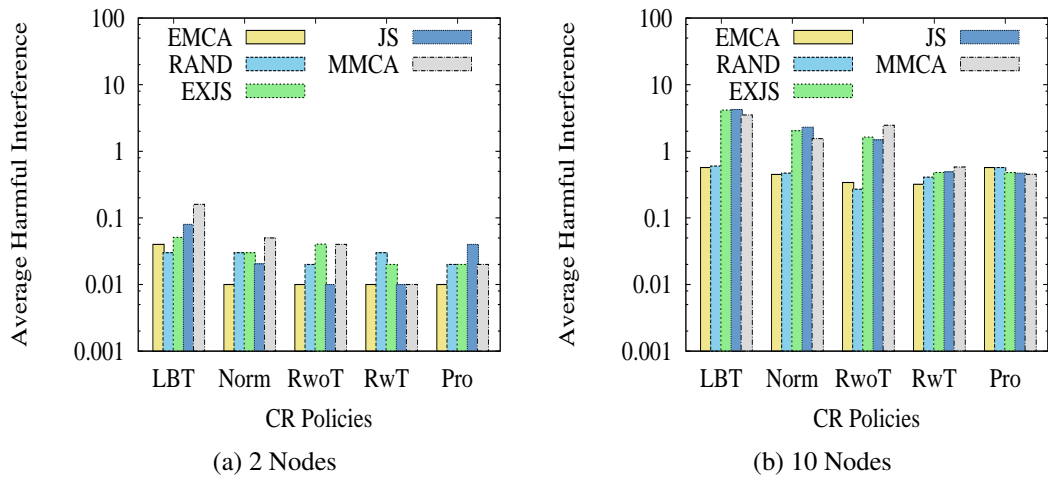

Figure A.26: Average HI for single-hop (7 ch, 10 BL TSs and Long PR activity).

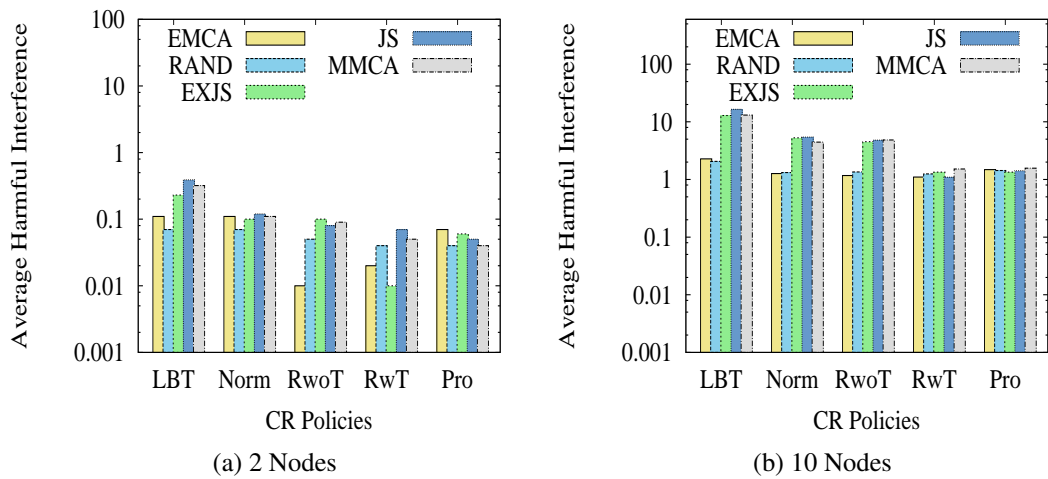

Figure A.27: Avg HI for single-hop (7 ch, 10 BL TSs and Intermittent PR activity).

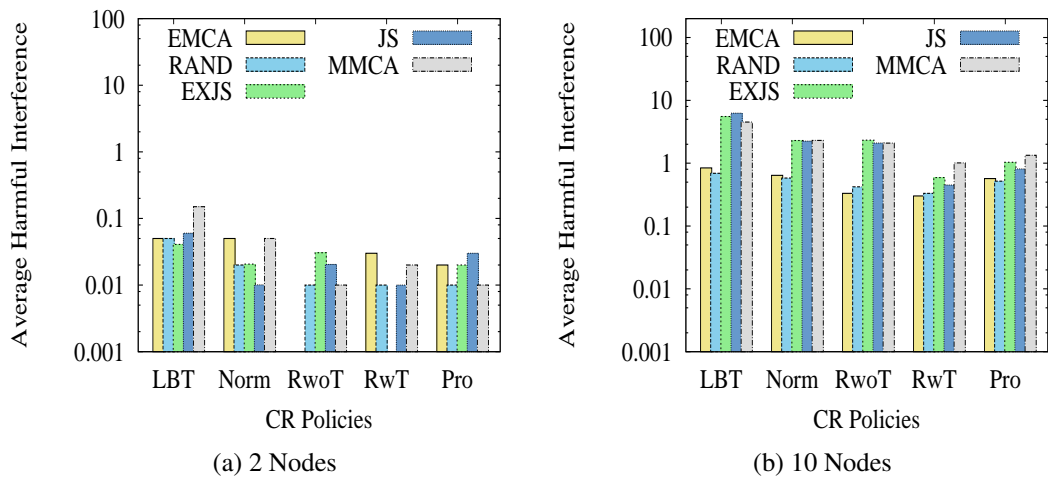

Figure A.28: Average HI for single-hop (7 ch, 10 BL TSs and Mix PR activity).

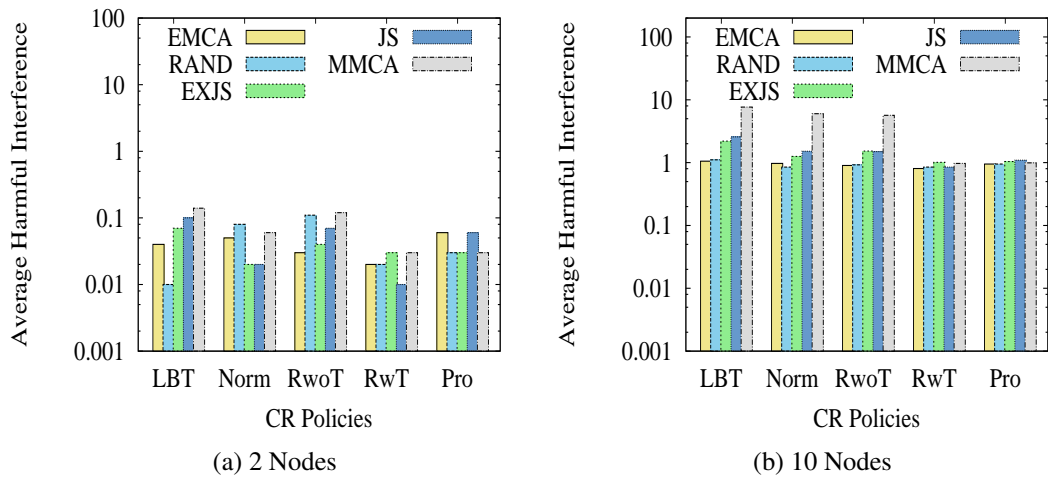

Figure A.29: Average HI for single-hop (14 ch, 10 BL TSs and Low PR activity).

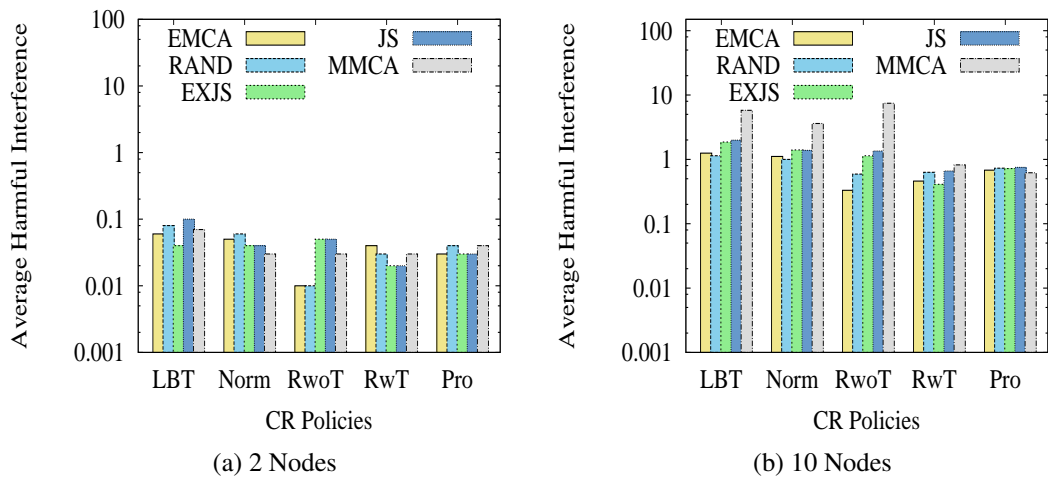

Figure A.30: Average HI for single-hop (14 ch, 10 BL TSs and Long PR activity).

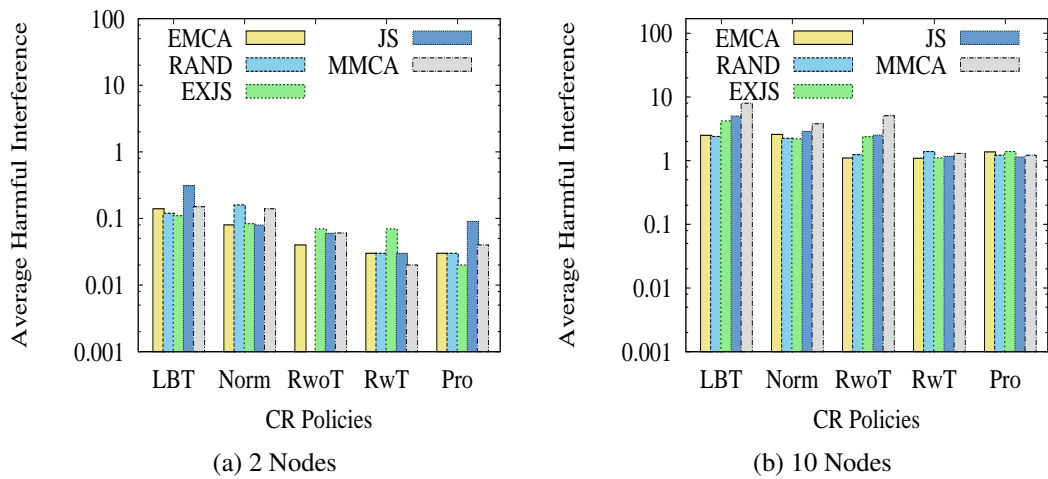

Figure A.31: Average HI for single-hop (14 ch, 10 BL TSs and High PR activity).

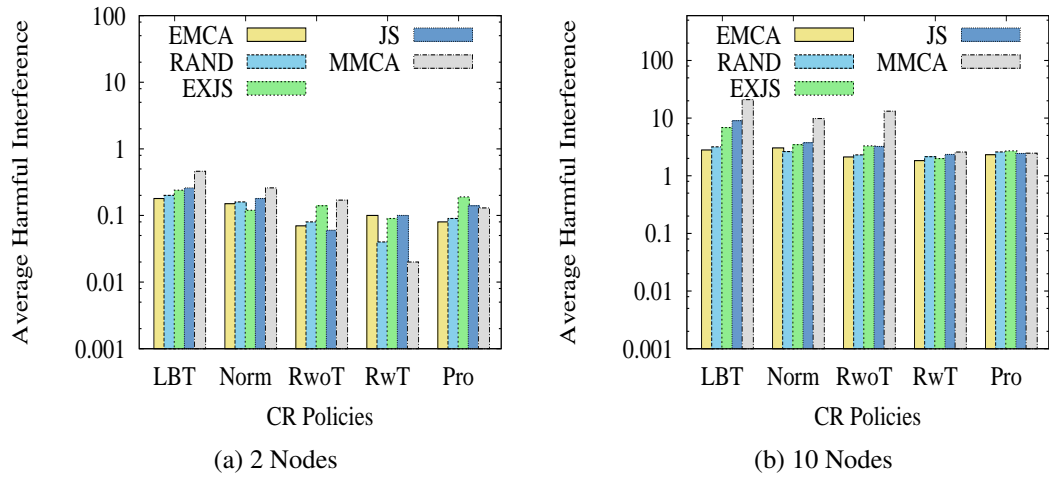

Figure A.32: Avg HI for single-hop (14 ch, 10 BL TSs and Intermittent PR activity).

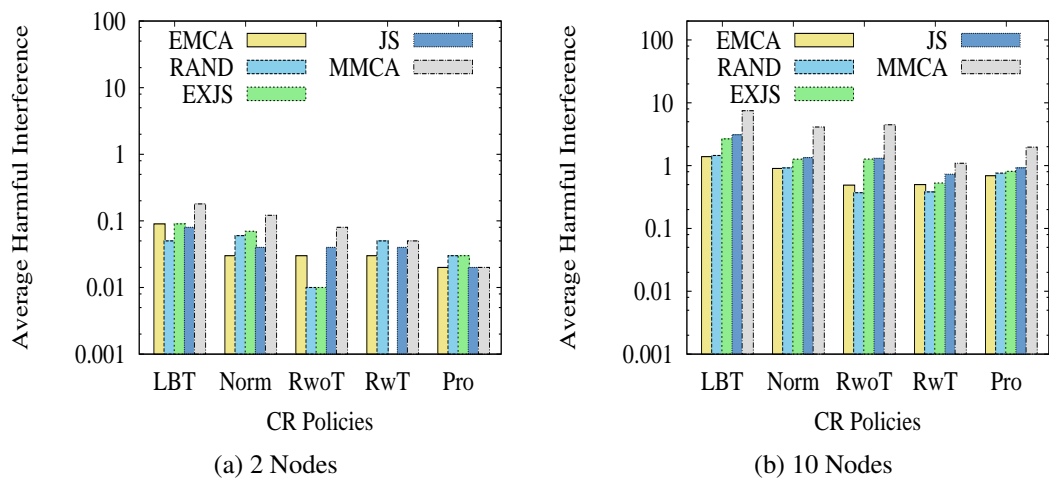

Figure A.33: Average HI for single-hop (14 ch, 10 BL TSs and Mix PR activity).

A.2 Chapter 7

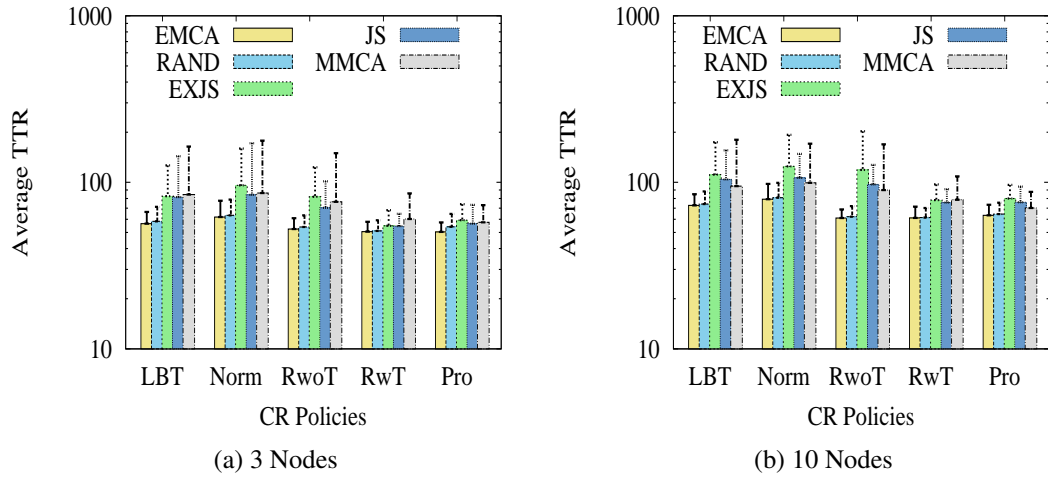

Figure A.34: Average TTR for multihop (7 ch, 3 BL TSs and Low PR activity).

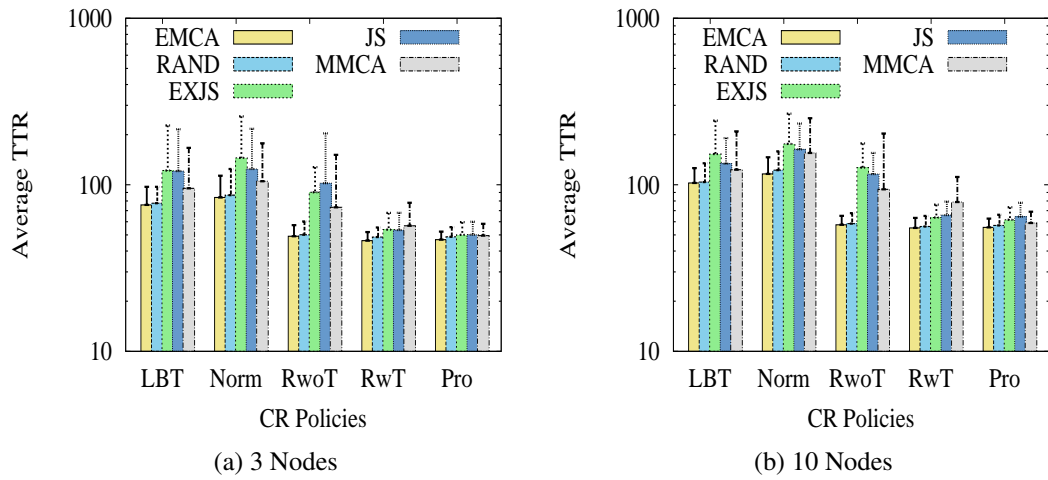

Figure A.35: Average TTR for multihop (7 ch, 3 BL TSs and Long PR activity).

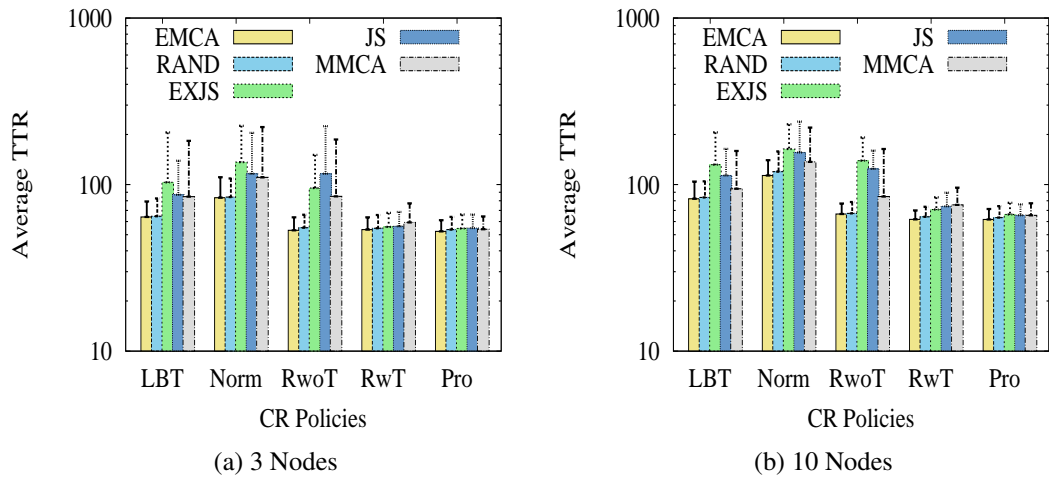

Figure A.36: Average TTR for multihop (7 ch, 3 BL TSs and Intermittent PR activity).

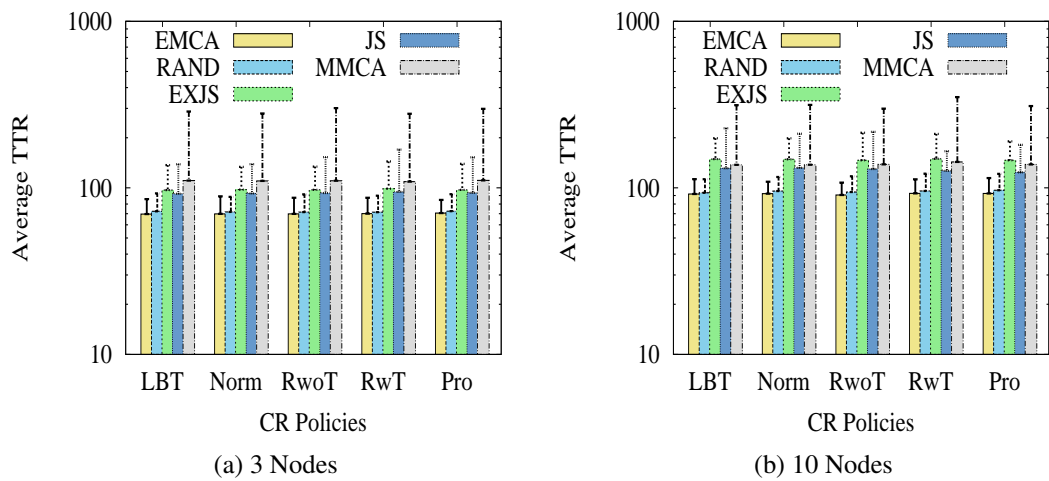

Figure A.37: Average TTR for multihop (14 ch, 3 BL TSs and Zero PR activity).

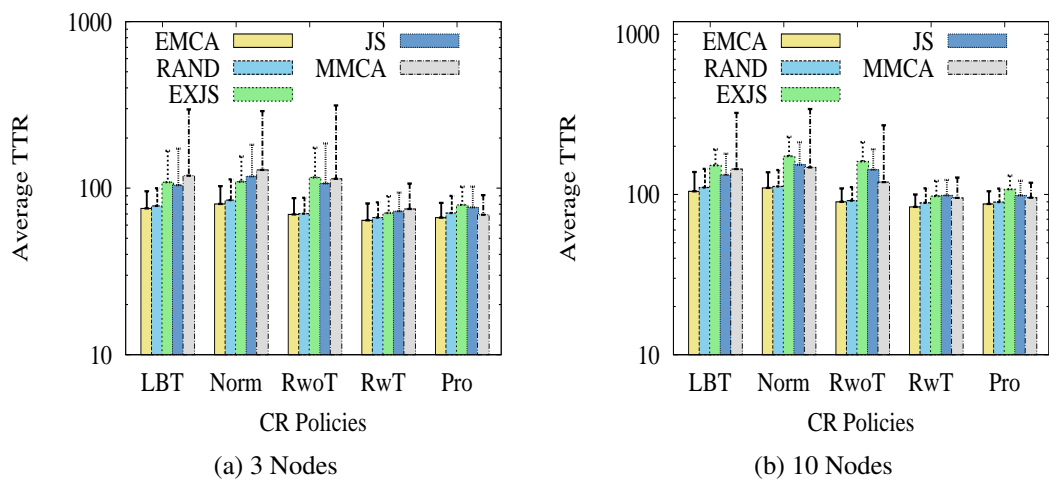

Figure A.38: Average TTR for multihop (14 ch, 3 BL TSs and Low PR activity).

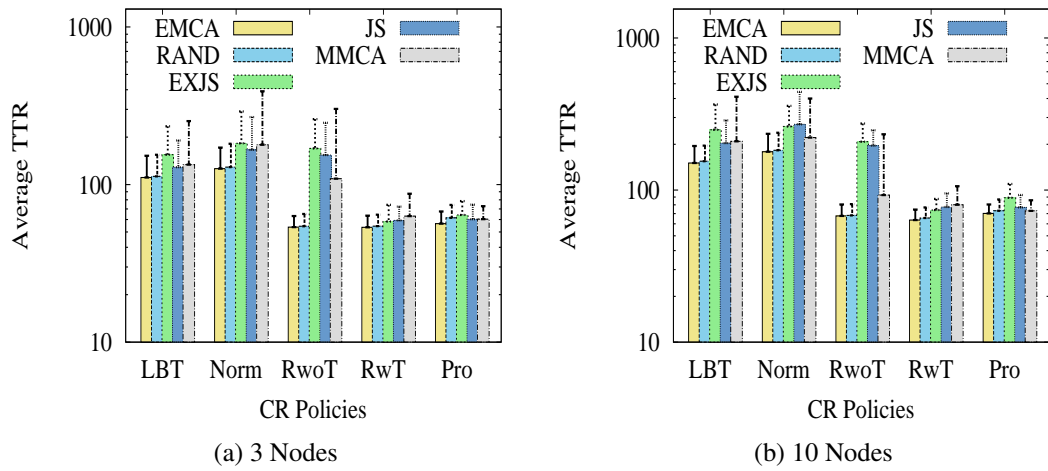

Figure A.39: Average TTR for multihop (14 ch, 3 BL TSs and Long PR activity).

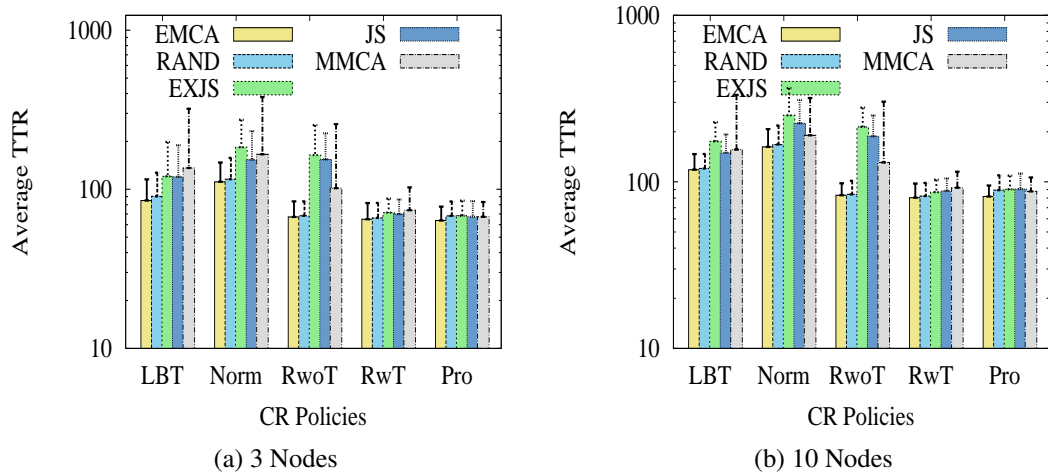

Figure A.40: Avg TTR for multihop (14 ch, 3 BL TSs and Intermittent PR activity).

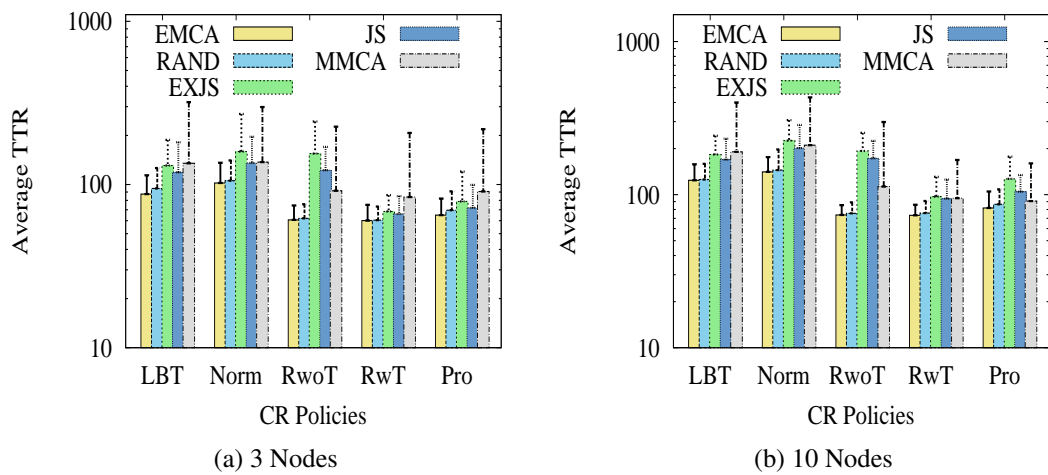

Figure A.41: Average TTR for multihop (14 ch, 3 BL TSs and Mix PR activity).

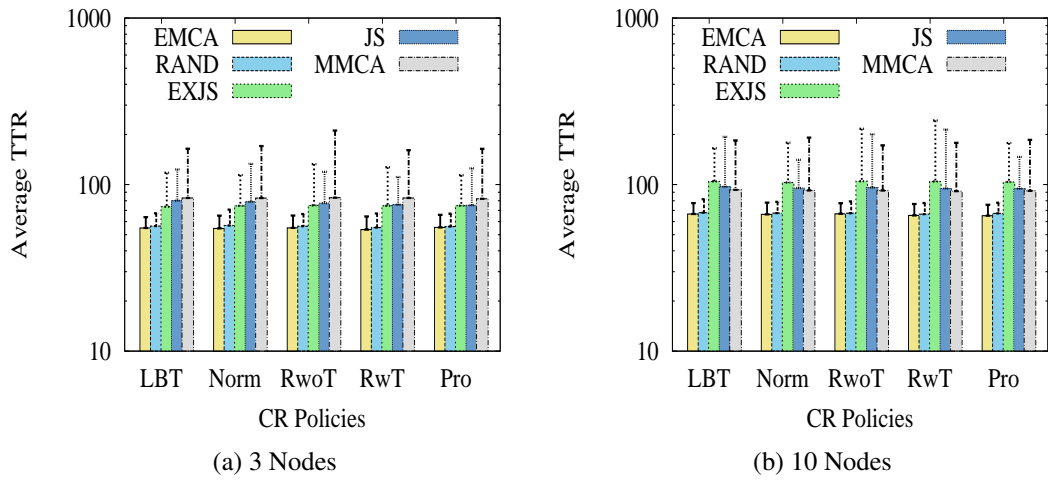

Figure A.42: Average TTR for multihop (7 ch, 10 BL TSs and Zero PR activity).

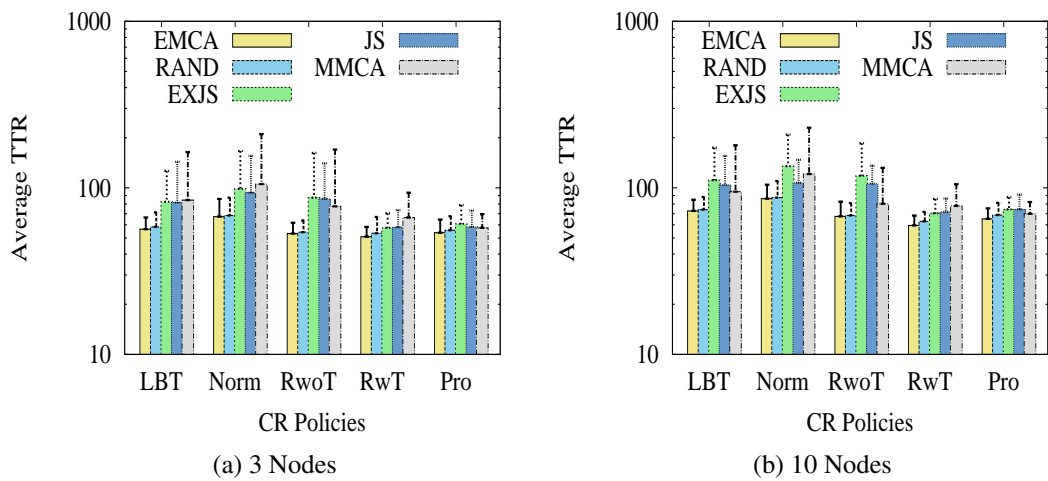

Figure A.43: Average TTR for multihop (7 ch, 10 BL TSs and Low PR activity).

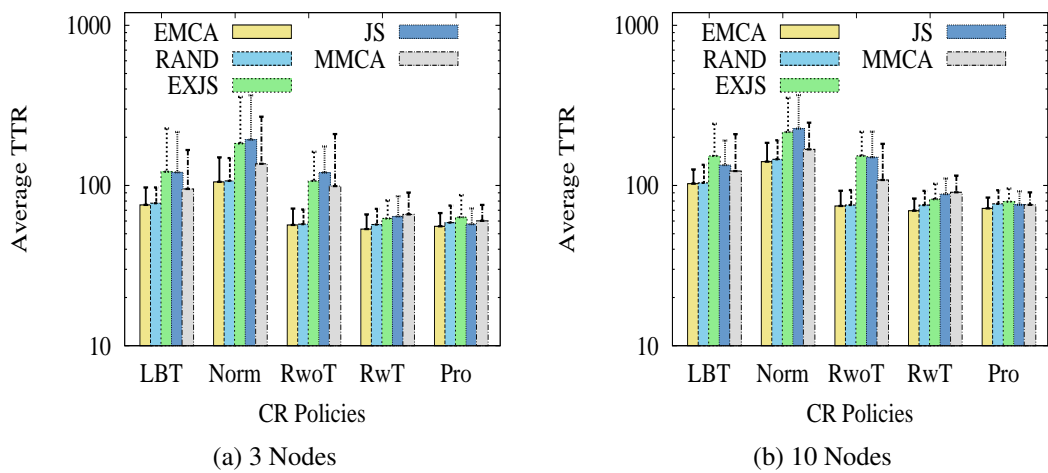

Figure A.44: Average TTR for multihop (7 ch, 10 BL TSs and Long PR activity).

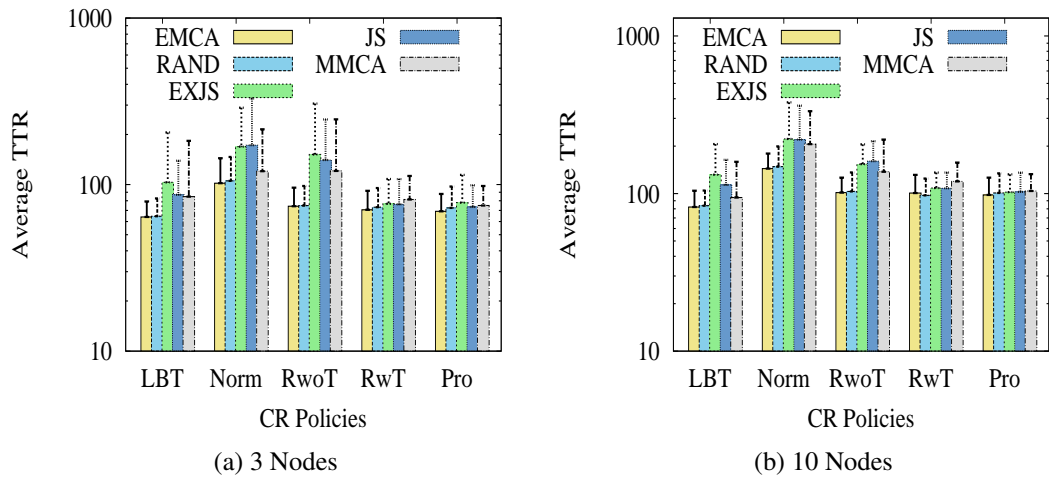

Figure A.45: Avg TTR for multihop (7 ch, 10 BL TSs and Intermittent PR activity).

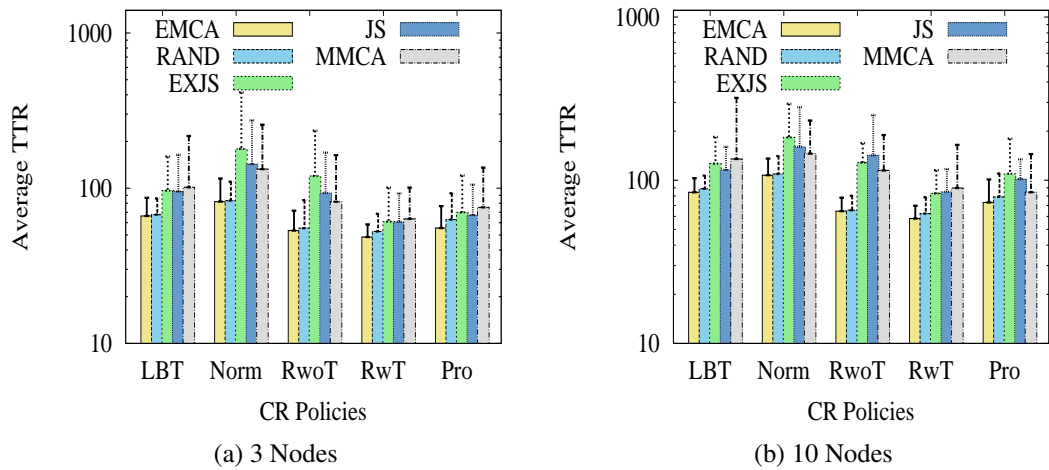

Figure A.46: Average TTR for multihop (7 ch, 10 BL TSs and Mix PR activity).

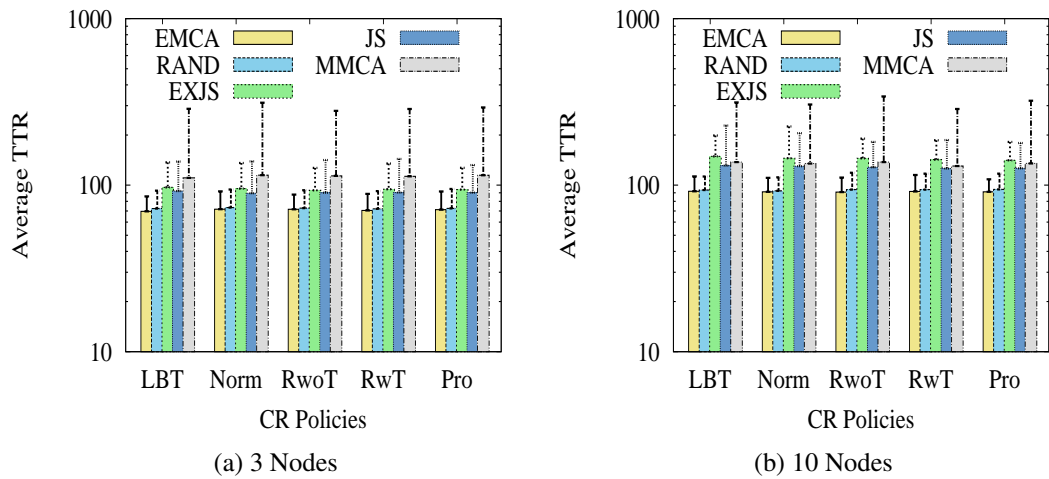

Figure A.47: Average TTR for multihop (14 ch, 10 BL TSs and Zero PR activity).

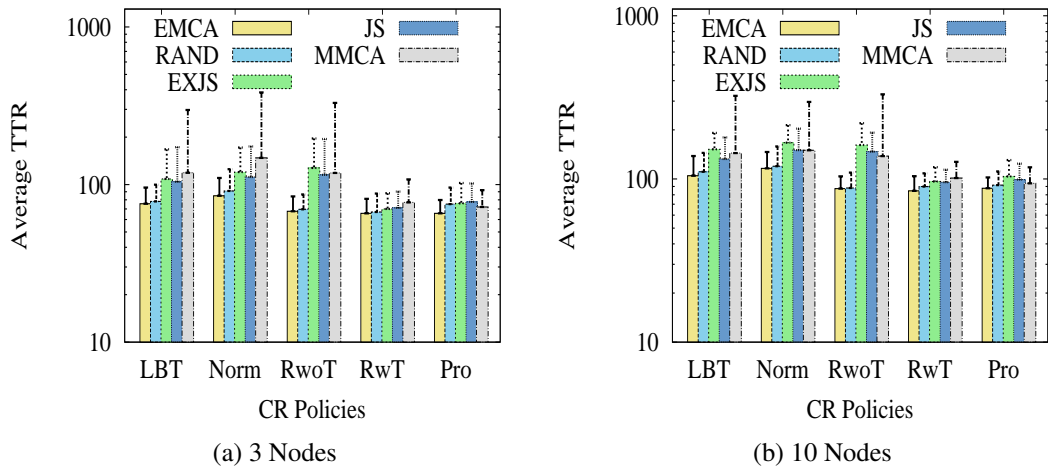

Figure A.48: Average TTR for multihop (14 ch, 10 BL TSs and Low PR activity).

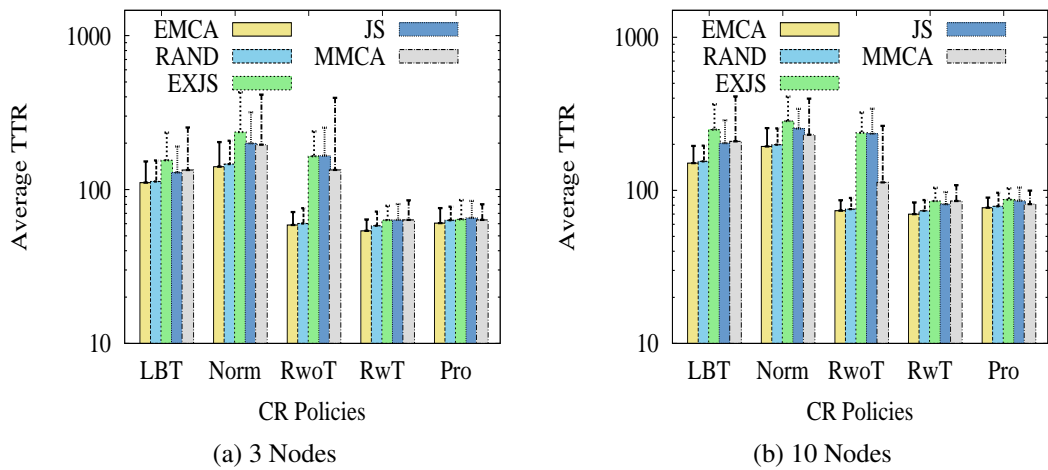

Figure A.49: Average TTR for multihop (14 ch, 10 BL TSs and Long PR activity).

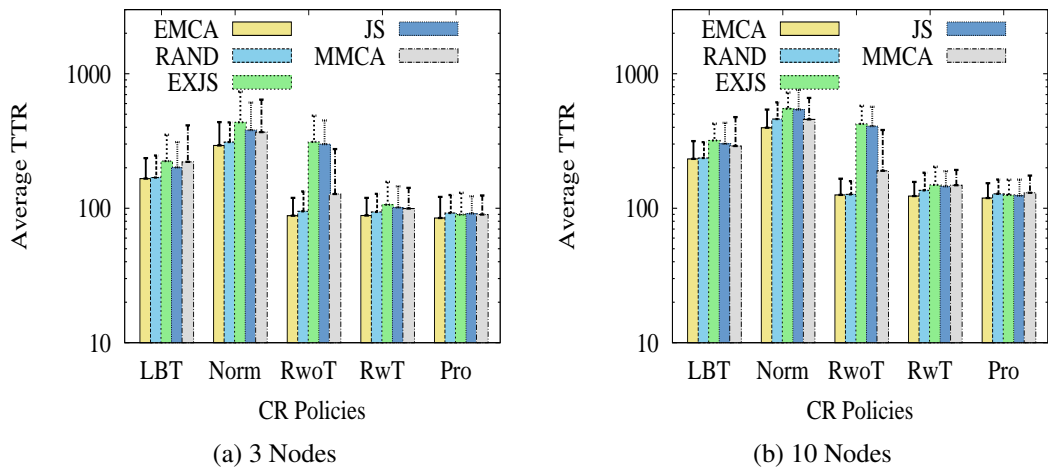

Figure A.50: Average TTR for multihop (14 ch, 10 BL TSs and High PR activity).

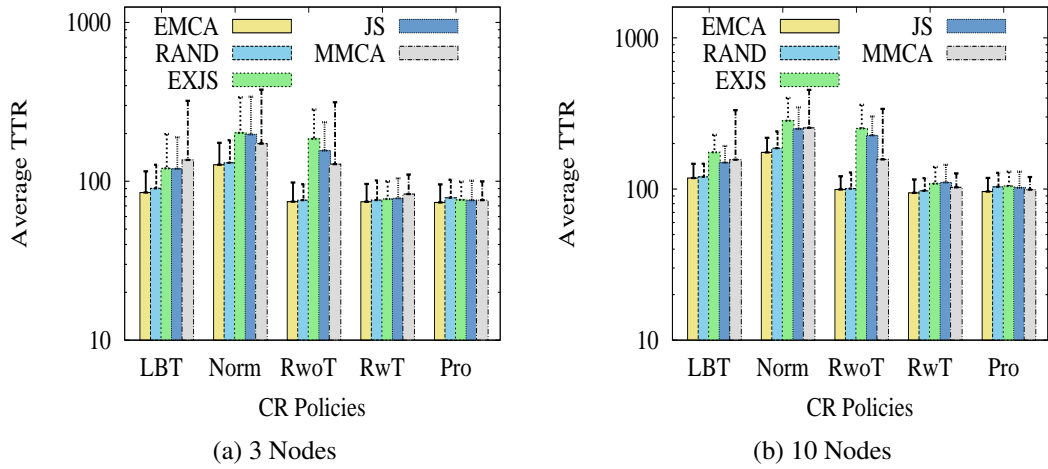

Figure A.51: Avg TTR for multihop (14 ch, 10 BL TSs and Intermittent PR activity).

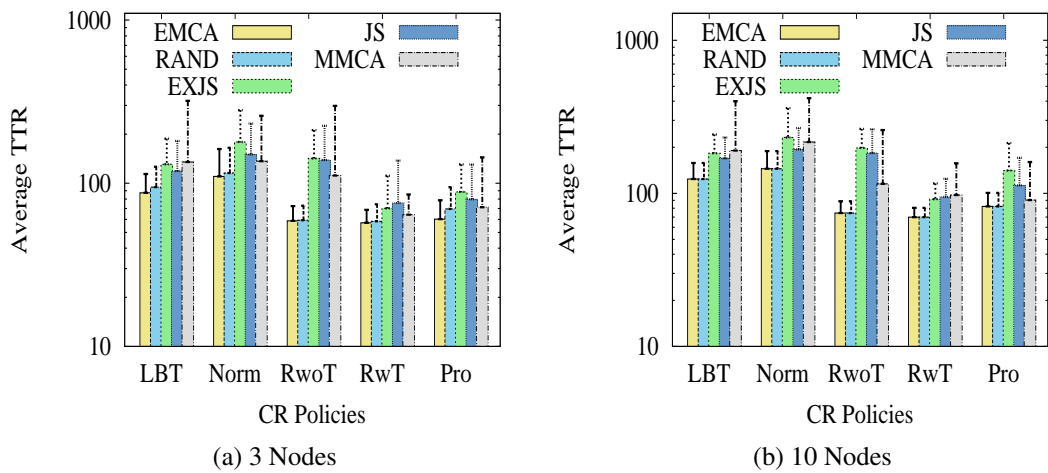

Figure A.52: Average TTR for multihop (14 ch, 10 BL TSs and Mix PR activity).

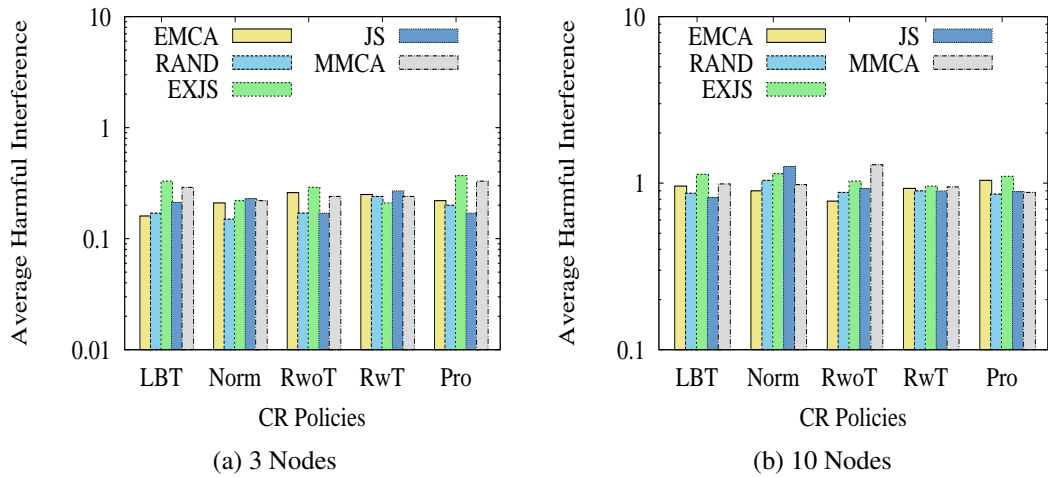

Figure A.53: Average HI for multihop (7 ch, 3 BL TSs and Low PR activity).

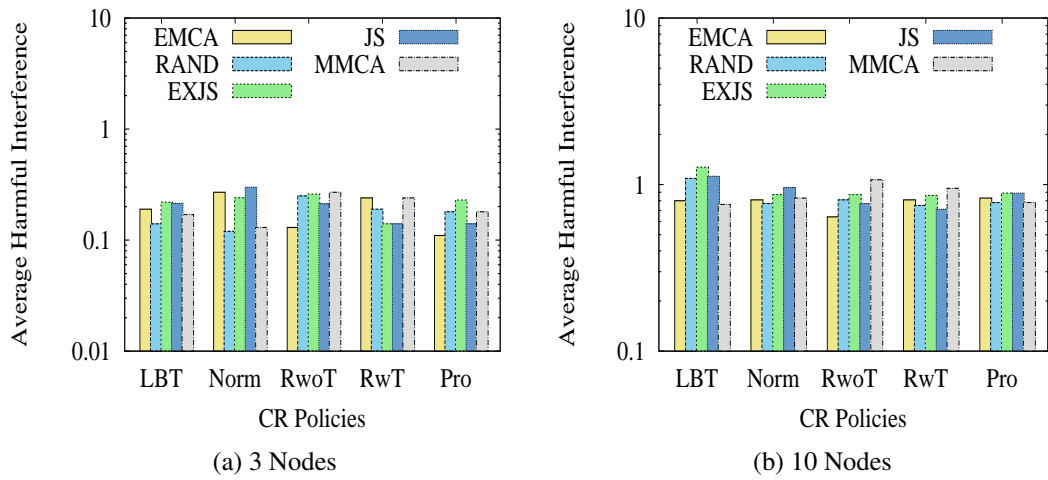

Figure A.54: Average HI for multihop (7 ch, 3 BL TSs and Long PR activity).

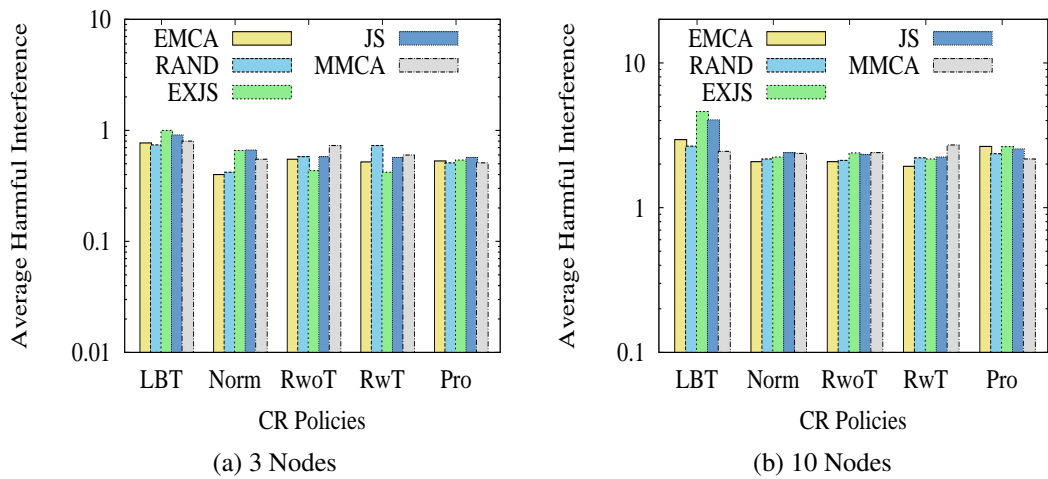

Figure A.55: Average HI for multihop (7 ch, 3 BL TSs and Intermittent PR activity).

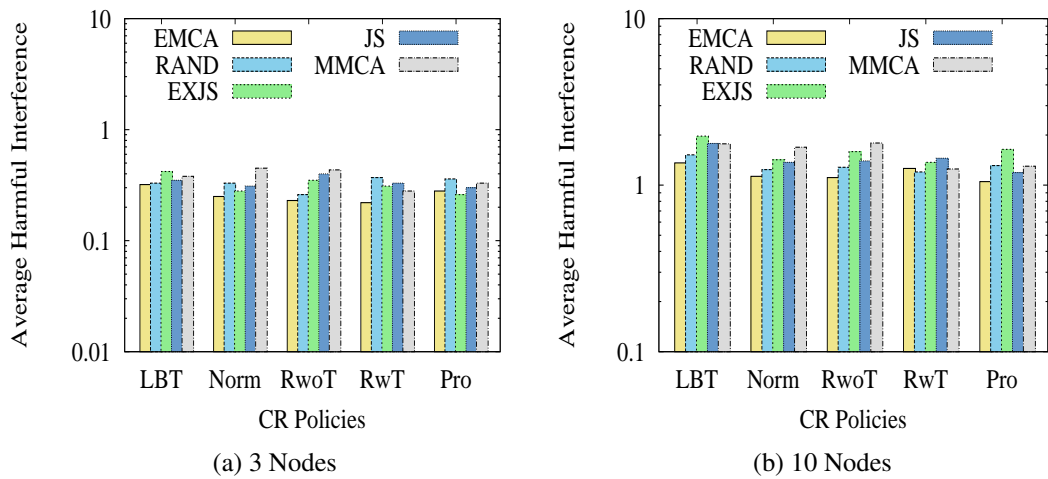

Figure A.56: Average HI for multihop (14 ch, 3 BL TSs and Low PR activity).

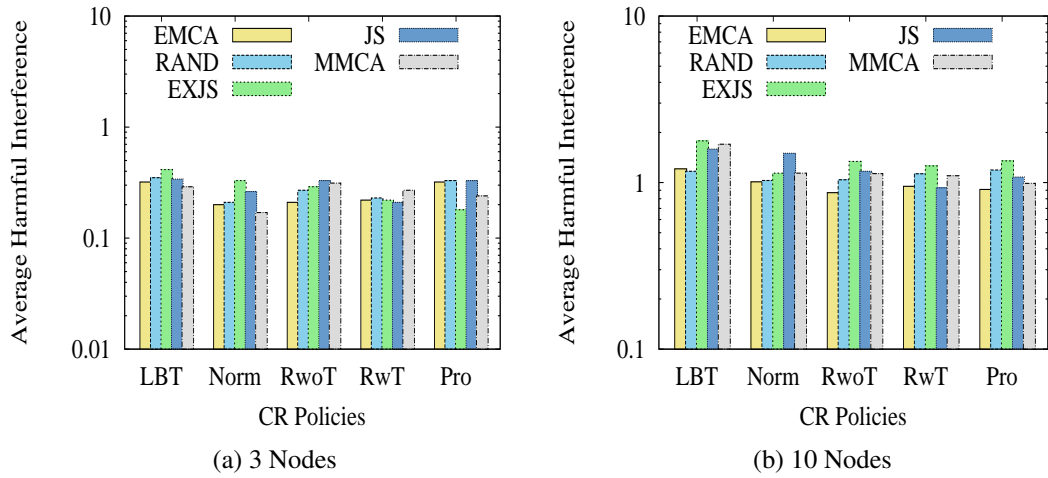

Figure A.57: Average HI for multihop (14 ch, 3 BL TSs and Long PR activity).

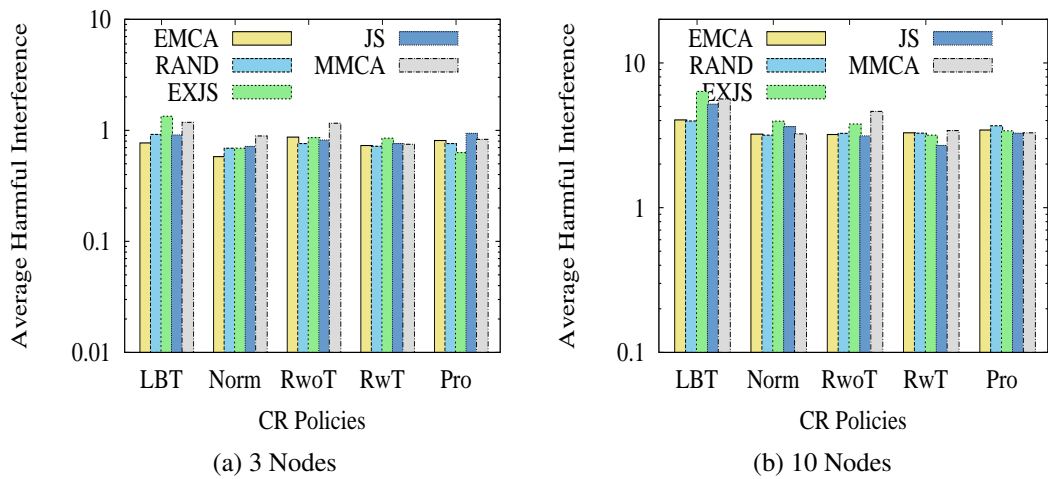

Figure A.58: Average HI for multihop (14 ch, 3 BL TSs and Intermittent PR activity).

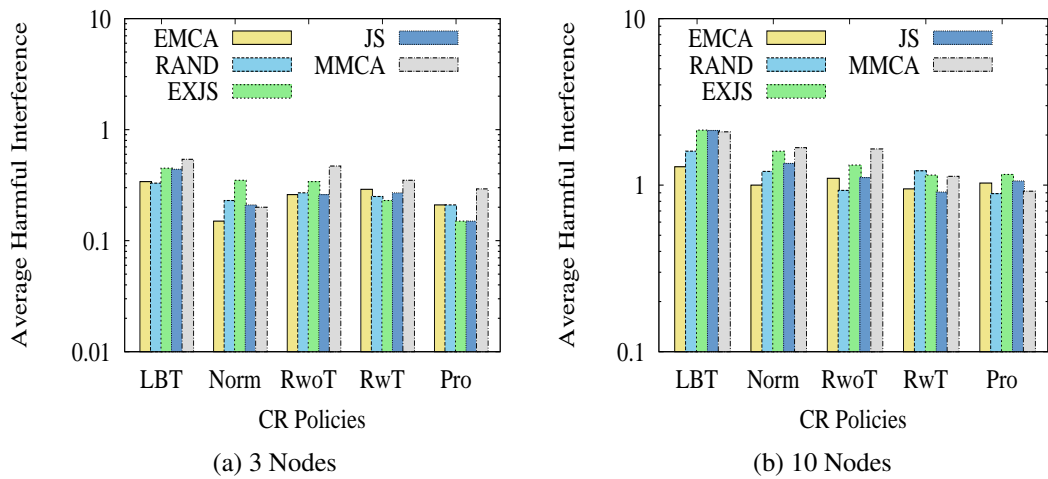

Figure A.59: Average HI for multihop (14 ch, 3 BL TSs and Mix PR activity).

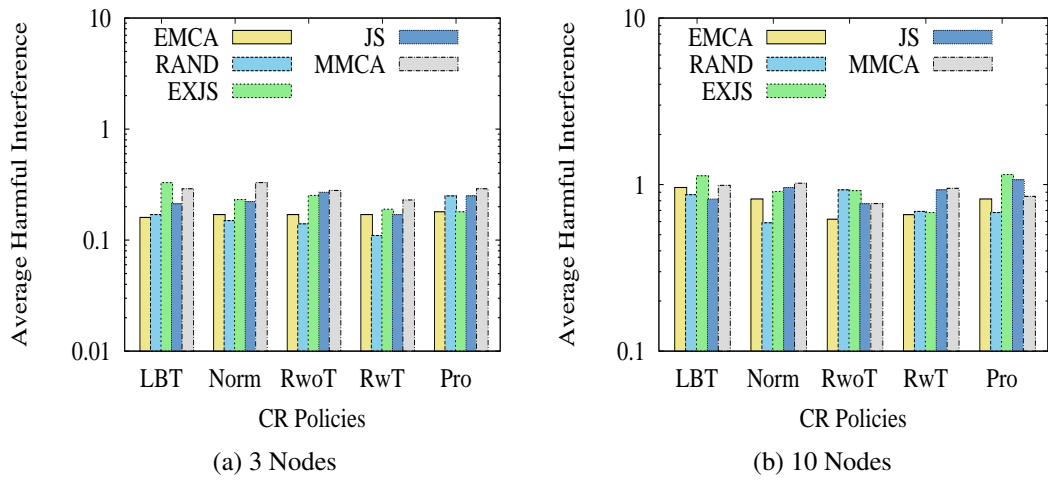

Figure A.60: Average HI for multihop (7 ch, 10 BL TSs and Low PR activity).

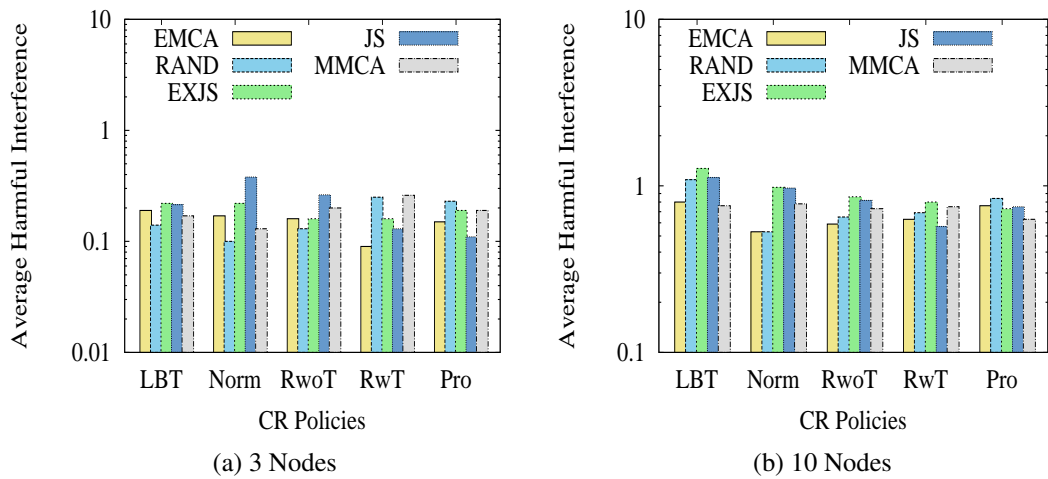

Figure A.61: Average HI for multihop (7 ch, 10 BL TSs and Long PR activity).

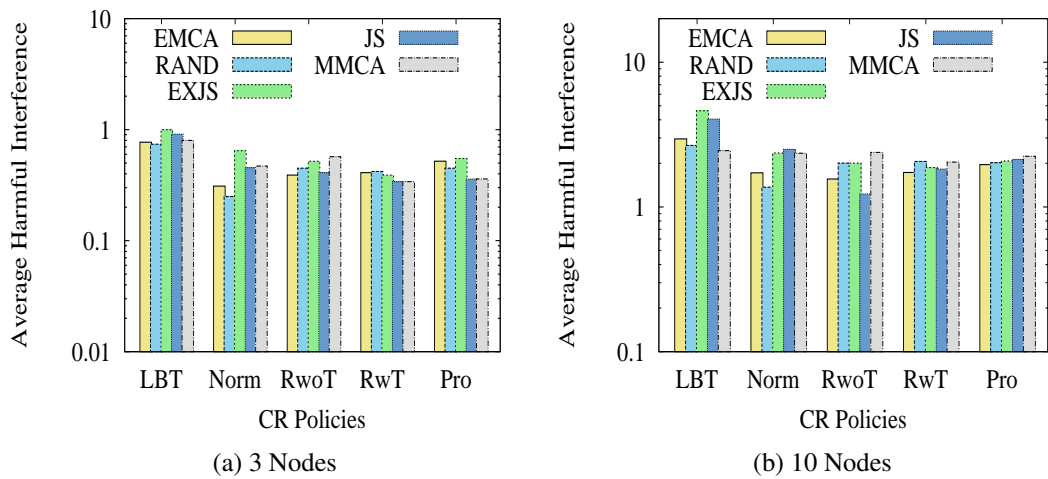

Figure A.62: Average HI for multihop (7 ch, 10 BL TSs and Intermittent PR activity).

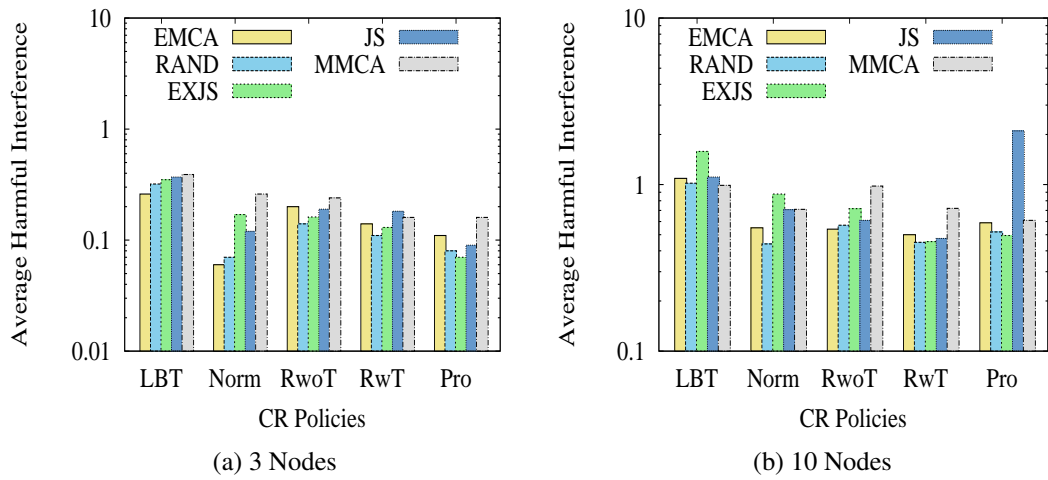

Figure A.63: Average HI for multihop (7 ch, 10 BL TSs and Mix PR activity).

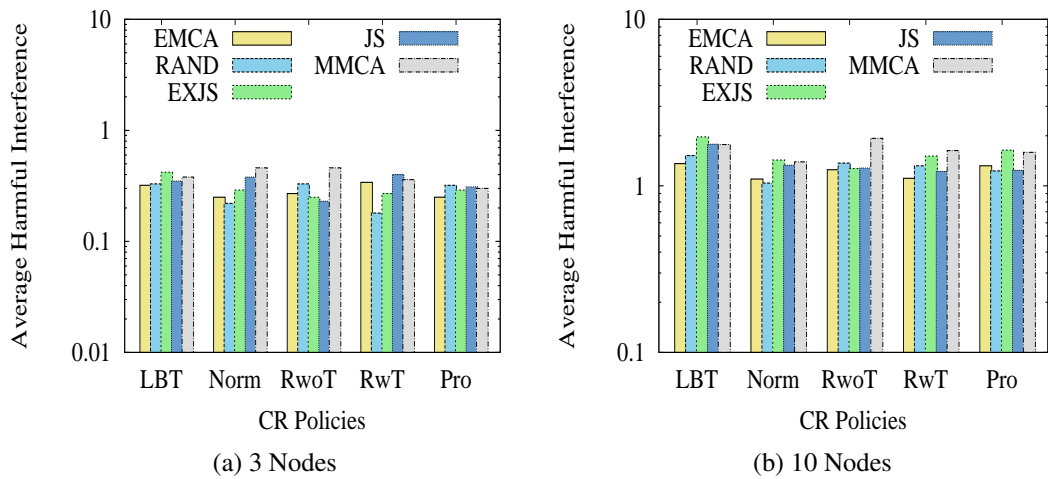

Figure A.64: Average HI for multihop (14 ch, 10 BL TSs and Low PR activity).

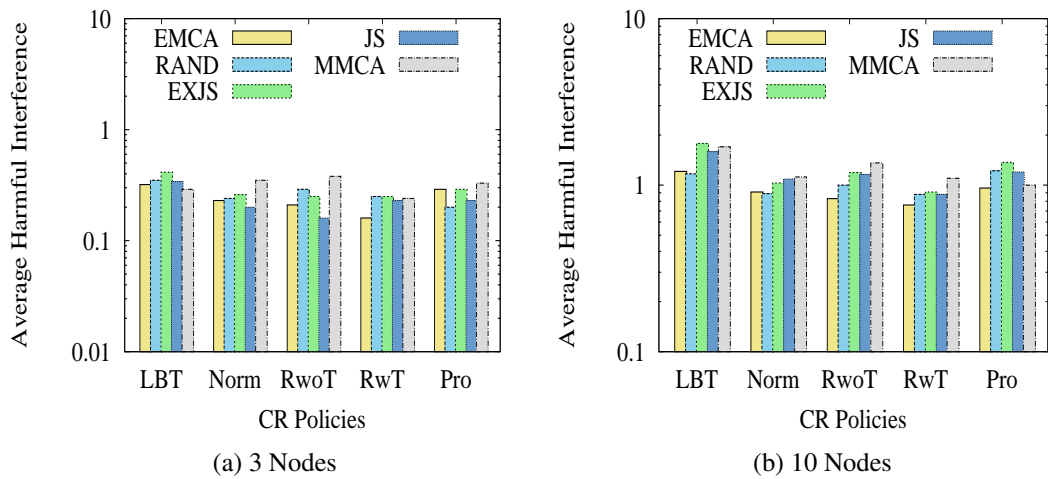

Figure A.65: Average HI for multihop (14 ch, 10 BL TSs and Long PR activity).

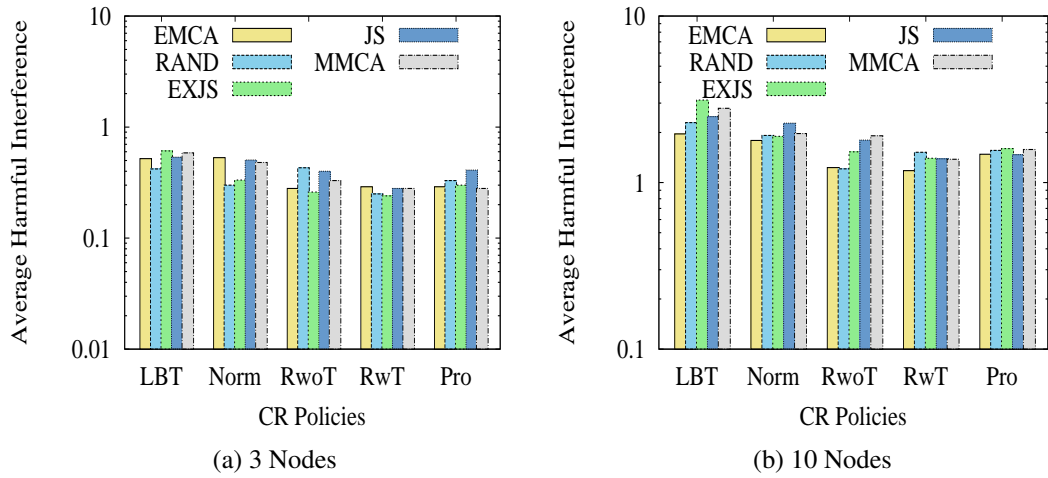

Figure A.66: Average HI for multihop (14 ch, 10 BL TSs and High PR activity).

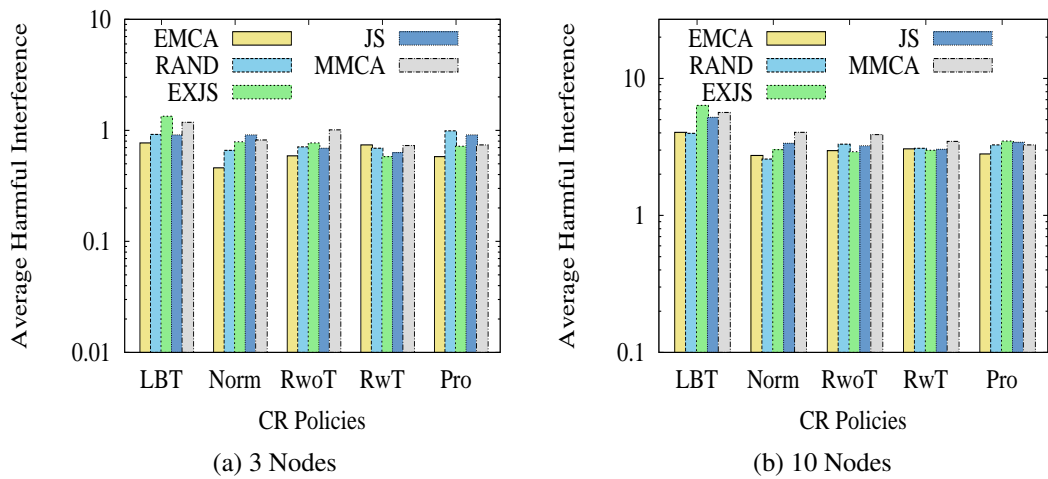

Figure A.67: Average HI for multihop (14 ch, 10 BL TSs and Intermittent PR activity).

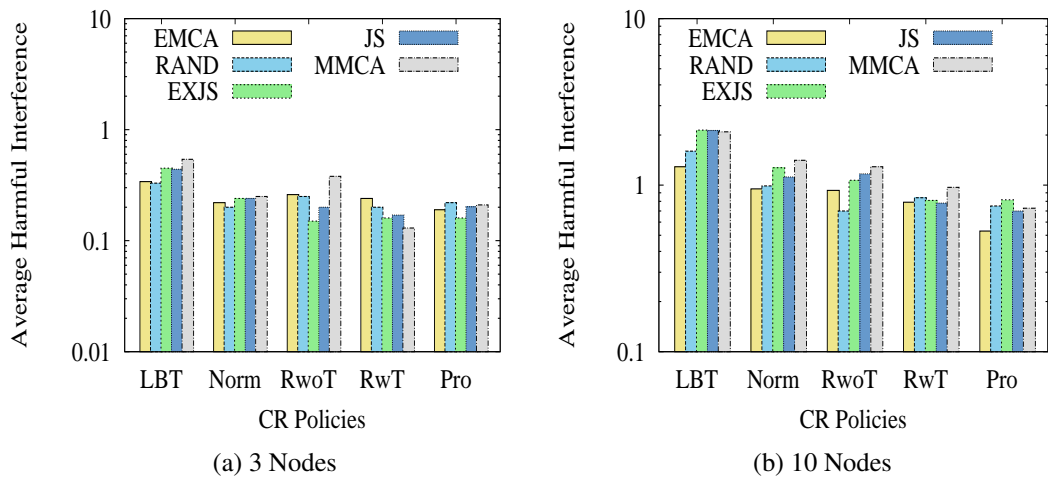

Figure A.68: Average HI for multihop (14 ch, 10 BL TSs and Mix PR activity).

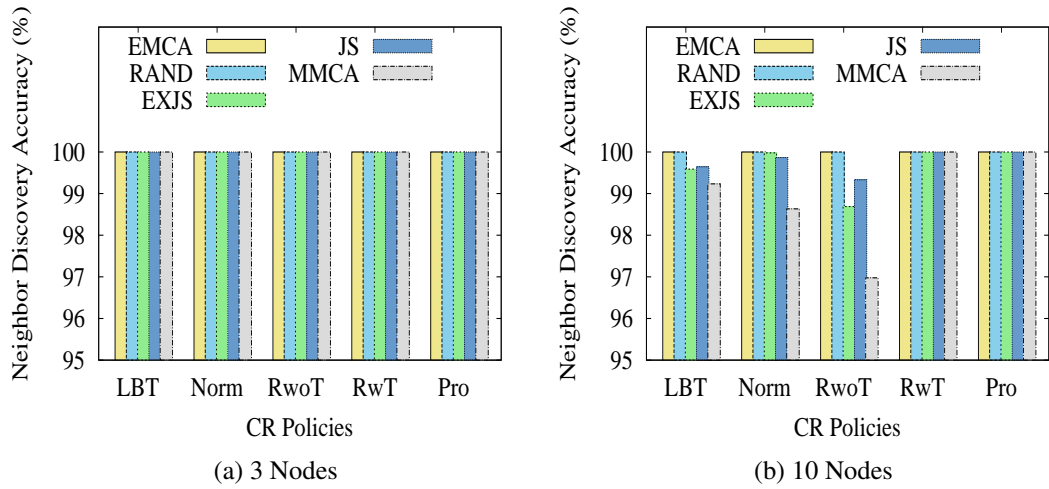

Figure A.69: Average NDA for multihop (7 ch, 3 BL TSs and Low PR activity).

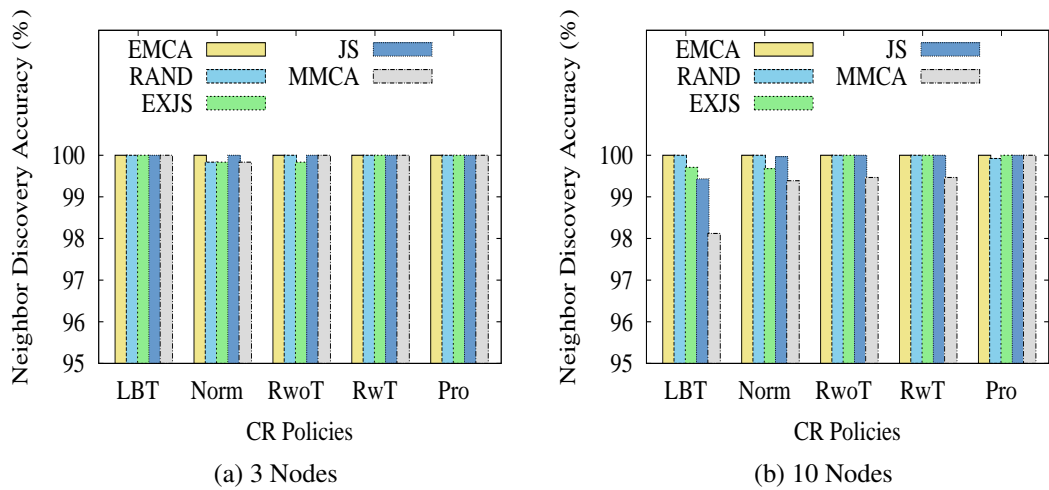

Figure A.70: Average NDA for multihop (7 ch, 3 BL TSs and Long PR activity).

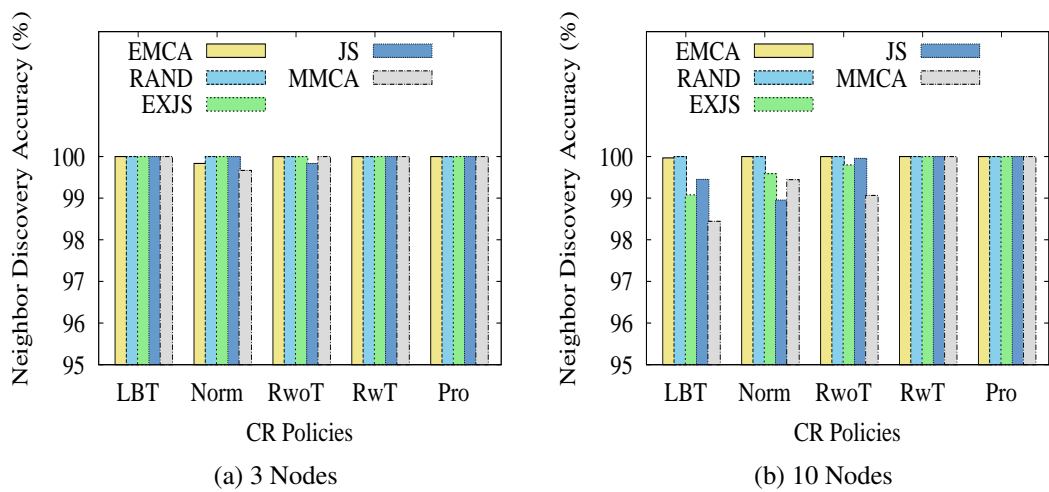

Figure A.71: Average NDA for multihop (7 ch, 3 BL TSs and Intermittent PR activity).

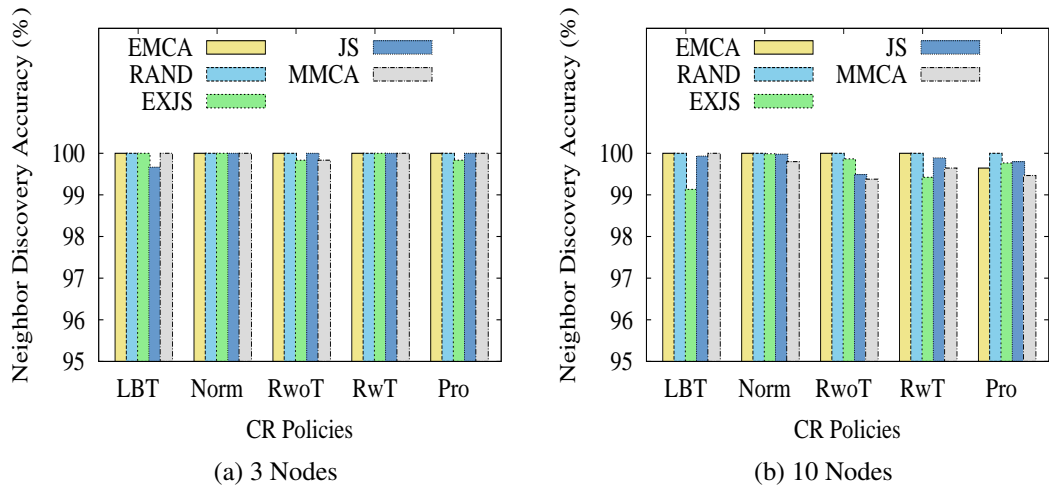

Figure A.72: Average NDA for multihop (14 ch, 3 BL TSs and Zero PR activity).

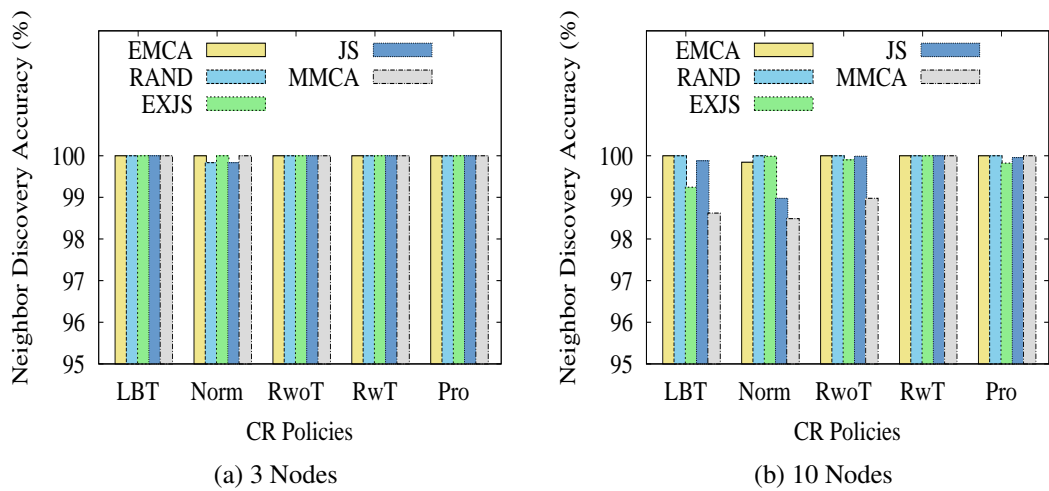

Figure A.73: Average NDA for multihop (14 ch, 3 BL TSs and Low PR activity).

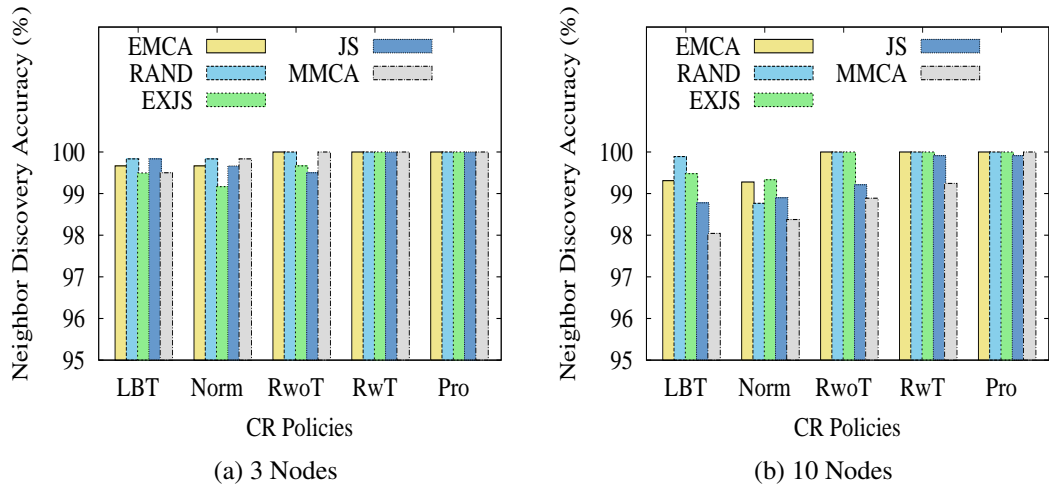

Figure A.74: Average NDA for multihop (14 ch, 3 BL TSs and Long PR activity).

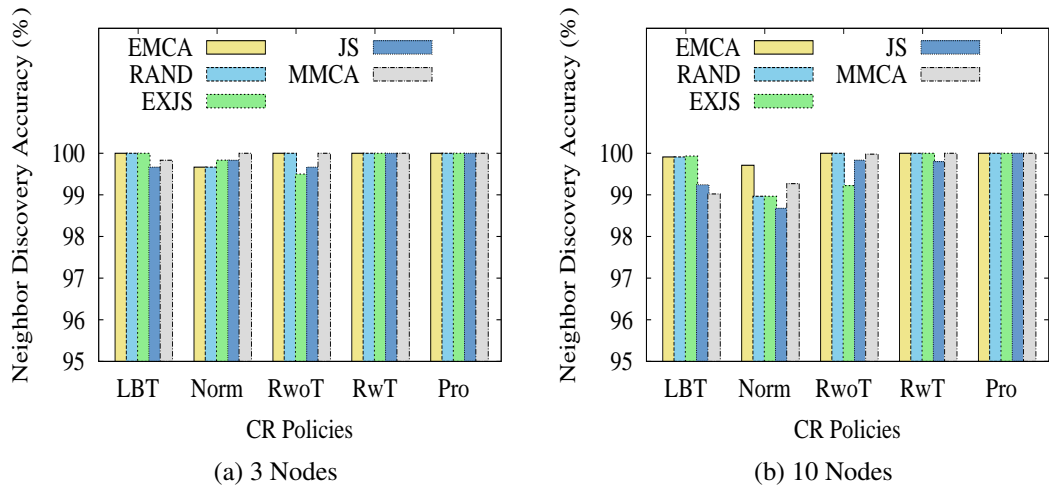

Figure A.75: Avg NDA for multihop (14 ch, 3 BL TSs and Intermittent PR activity).

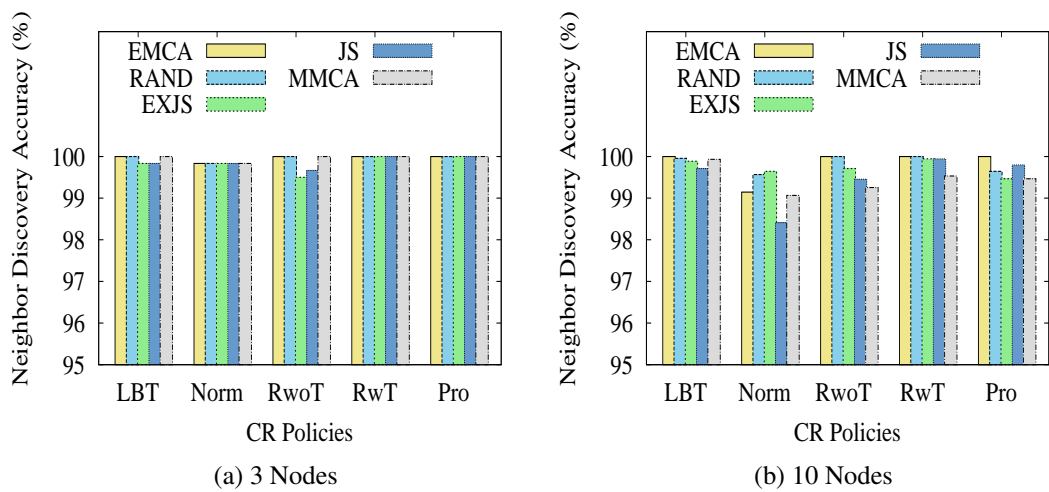

Figure A.76: Average NDA for multihop (14 ch, 3 BL TSs and Mix PR activity).

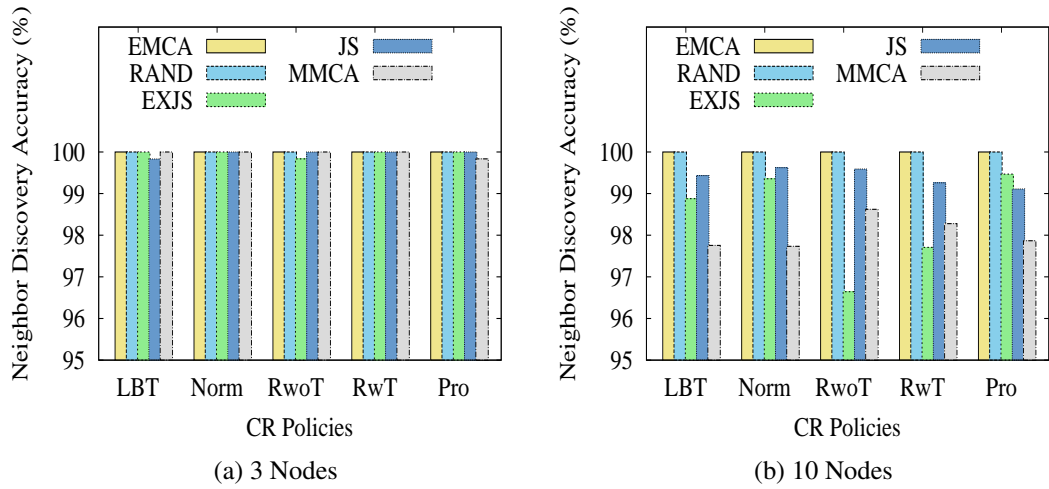

Figure A.77: Average NDA for multihop (7 ch, 10 BL TSs and Zero PR activity).

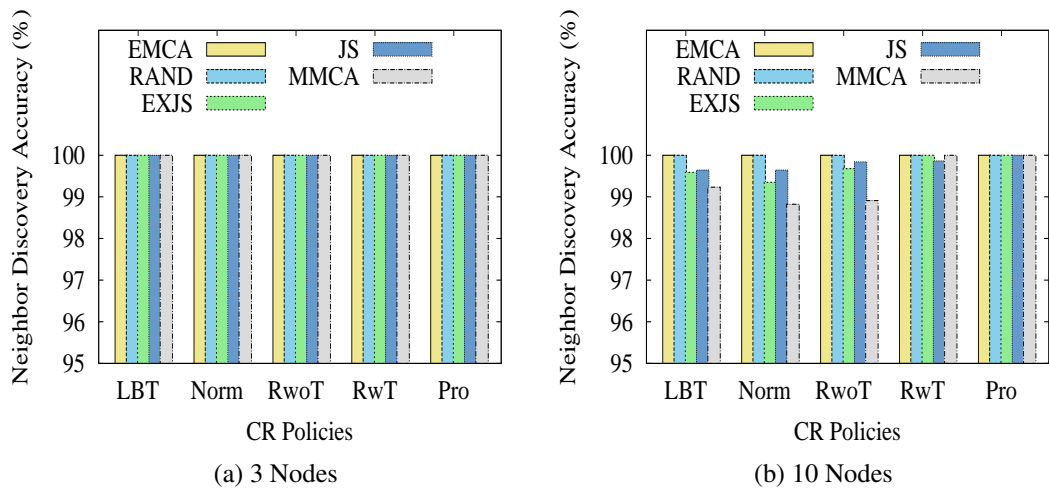

Figure A.78: Average NDA for multihop (7 ch, 10 BL TSs and Low PR activity).

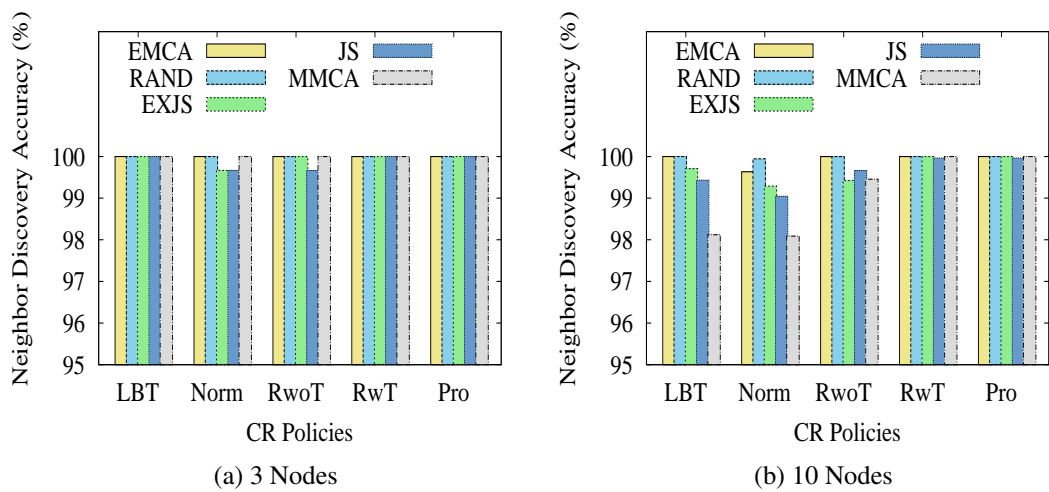

Figure A.79: Average NDA for multihop (7 ch, 10 BL TSs and Long PR activity).

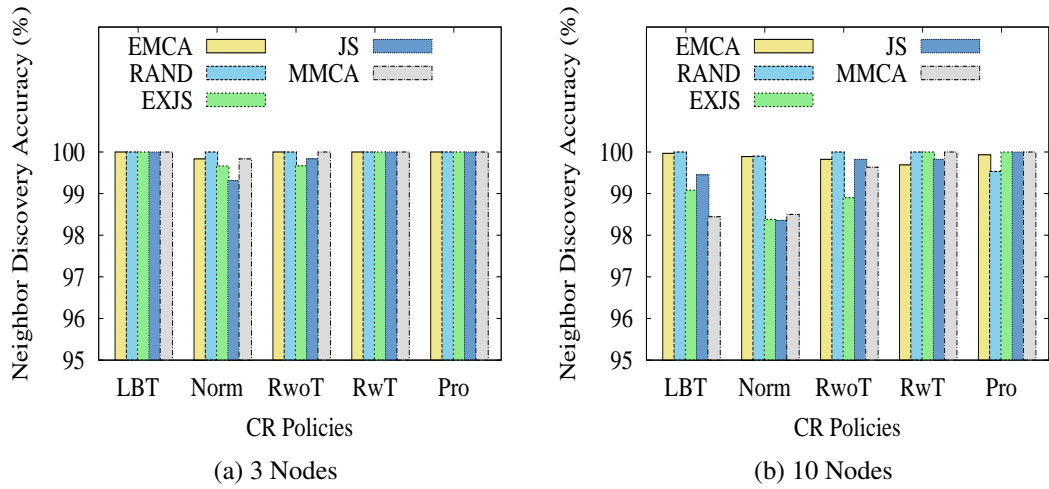

Figure A.80: Avg NDA for multihop (7 ch, 10 BL TSs and Intermittent PR activity).

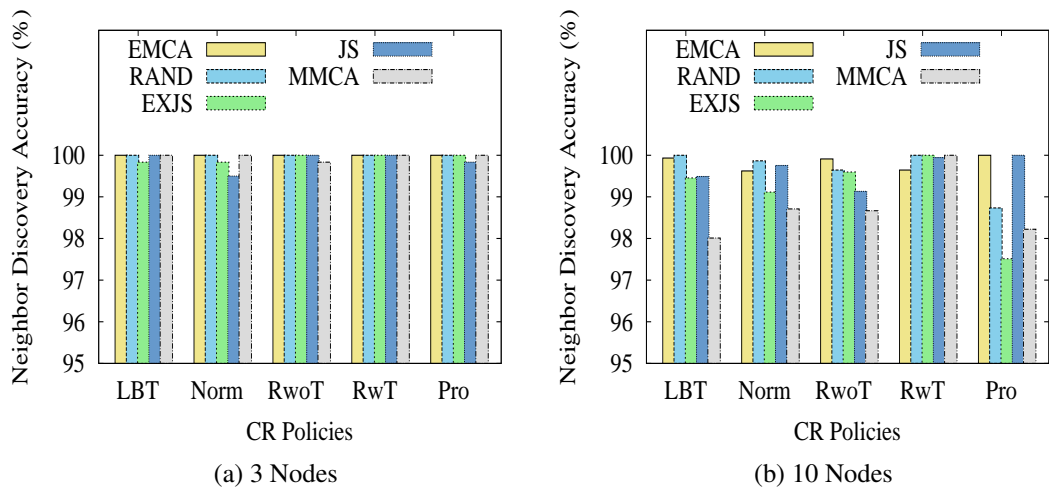

Figure A.81: Average NDA for multihop (7 ch, 10 BL TSs and Mix PR activity).

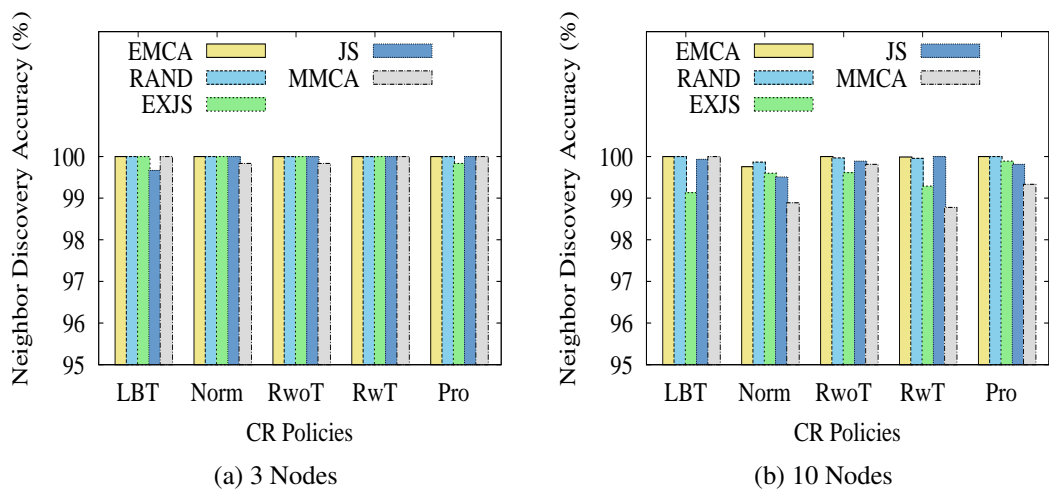

Figure A.82: Average NDA for multihop (14 ch, 10 BL TSs and Zero PR activity).

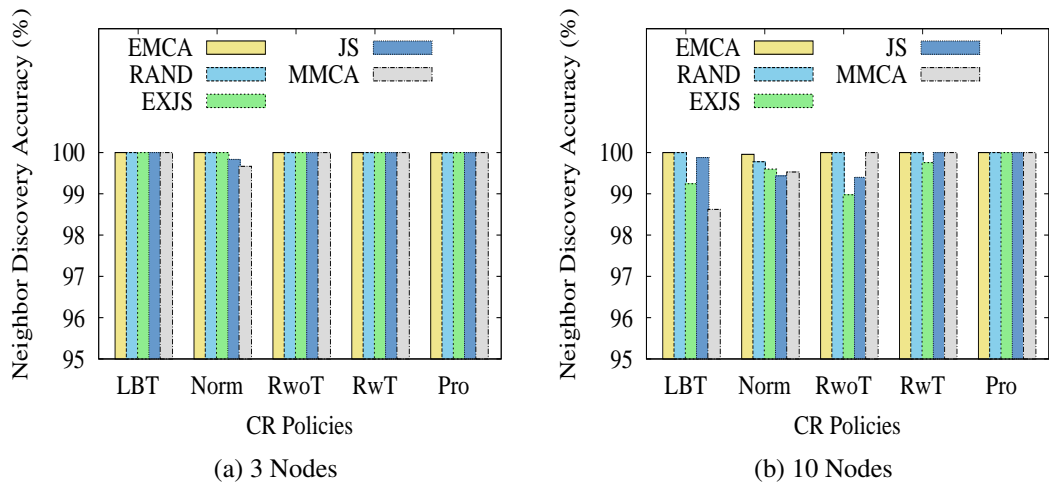

Figure A.83: Average NDA for multihop (14 ch, 10 BL TSs and Low PR activity).

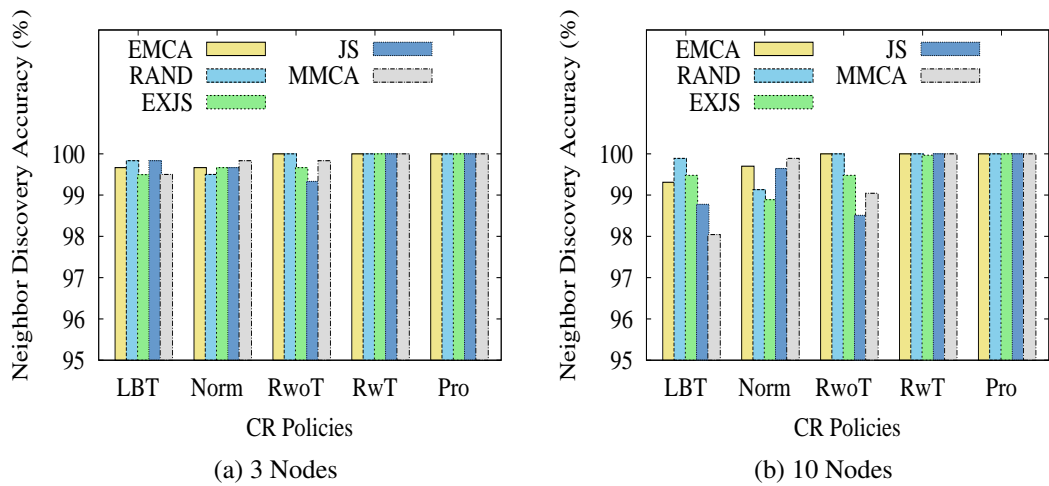

Figure A.84: Average NDA for multihop (14 ch, 10 BL TSs and Long PR activity).

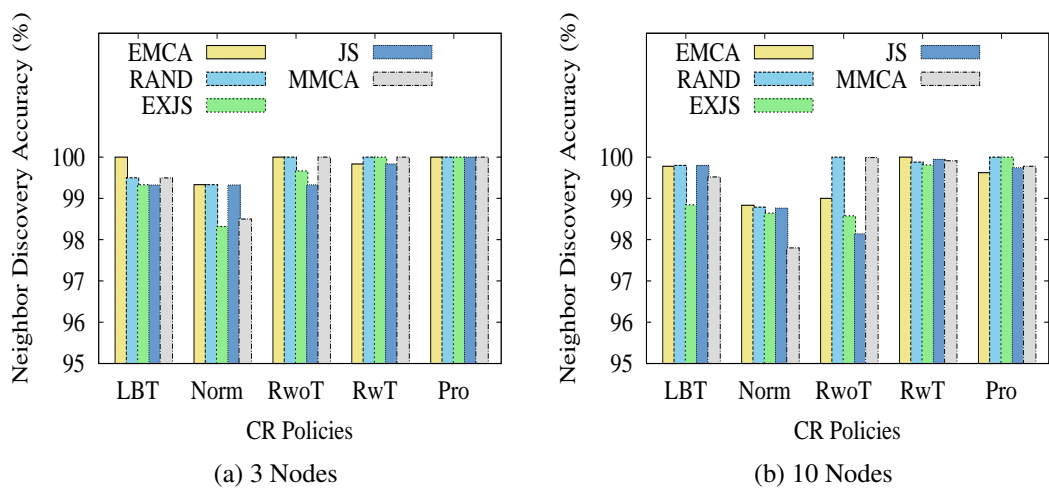

Figure A.85: Average NDA for multihop (14 ch, 10 BL TSs and High PR activity).

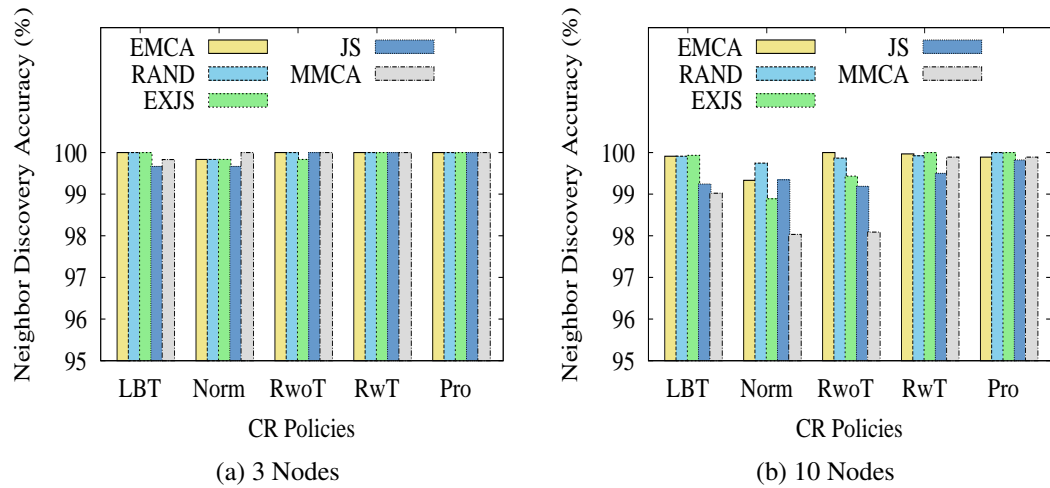

Figure A.86: Avg NDA for multihop (14 ch, 10 BL TSs and Intermittent PR activity).

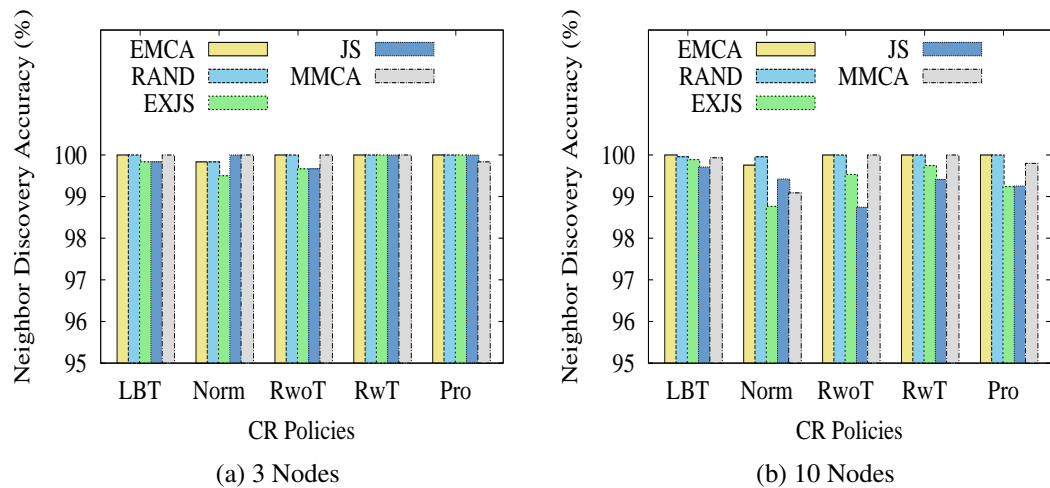

Figure A.87: Average NDA for multihop (14 ch, 10 BL TSs and Mix PR activity).

Appendix B

Tables

B.1 Chapter 6

Table B.1: Percentage improvement of EMCA over other rendezvous strategies in terms of ATTR (2 nodes, 3 BL TS)

		7 channels						14 channels					
		ZERO	LOW	LONG	HIGH	INTER	MIXPR	ZERO	LOW	LONG	HIGH	INTER	MIXPR
RANDOM	No	12.79	7.57	9.98	8.05	10.31	11.68	6.82	9.57	3.80	5.24	1.84	4.57
	Norm	7.31	21.41	8.32	3.46	10.26	14.47	3.05	18.33	16.90	27.17	21.21	17.74
	RwoT	16.82	12.66	13.52	7.58	2.49	19.26	9.50	13.40	2.25	22.20	8.39	5.94
	RwT	15.71	14.46	22.61	15.28	15.80	14.33	4.05	9.07	23.46	16.38	13.92	19.51
	Pro	15.85	4.11	13.61	7.69	5.73	11.76	4.91	11.22	8.62	9.09	12.17	17.78
JS	No	56.83	65.98	61.90	64.08	72.82	66.49	49.68	50.57	36.43	33.95	43.78	48.83
	Norm	58.32	68.64	56.78	48.14	61.50	52.73	45.55	45.60	32.69	32.98	44.05	55.55
	RwoT	57.65	57.74	75.89	82.11	74.79	83.15	46.27	58.30	81.64	89.01	68.42	78.72
	RwT	60.55	24.90	35.79	42.38	21.23	46.03	46.09	20.99	20.78	28.78	8.36	22.01
	Pro	61.57	18.78	25.34	25.08	19.25	46.49	40.21	18.73	12.92	16.79	7.42	16.08
MMCA	No	73.86	76.51	64.72	49.96	64.38	71.21	71.36	67.06	47.71	25.40	65.09	66.42
	Norm	74.50	79.67	63.66	40.48	40.26	63.14	73.10	69.46	48.49	28.62	41.13	70.63
	RwoT	73.22	69.59	83.76	81.02	79.15	58.69	72.73	72.26	76.39	77.83	43.21	78.41
	RwT	76.69	55.20	58.31	50.93	47.14	73.10	72.91	47.28	45.01	52.90	22.42	73.93
	Pro	76.22	29.56	37.74	33.46	29.14	58.51	69.73	37.83	13.40	24.97	16.32	20.97
EXJS	No	48.91	50.14	31.85	44.73	66.52	49.49	37.53	43.24	18.32	37.75	19.46	26.68
	Norm	49.92	68.08	50.24	39.09	58.79	50.44	40.10	38.37	40.64	37.78	48.29	28.69
	RwoT	51.57	65.93	83.22	78.97	77.61	81.49	39.89	60.05	85.22	90.64	73.59	73.31
	RwT	53.82	25.65	32.82	42.03	31.21	41.77	37.37	6.14	15.72	37.06	21.54	9.59
	Pro	54.64	27.36	12.85	28.38	14.27	32.01	33.77	21.68	13.49	16.92	10.61	19.87

Table B.2: Percentage improvement of EMCA over other rendezvous strategies in terms of ATTR (10 nodes, 3 BL TS)

		7 channels						14 channels					
		ZERO	LOW	LONG	HIGH	INTER	MIXPR	ZERO	LOW	LONG	HIGH	INTER	MIXPR
RANDOM	No	3.03	4.21	2.62	3.77	2.83	1.03	4.80	1.30	1.49	2.73	7.10	1.54
	Norm	-0.62	0.67	0.74	3.38	0.38	0.90	2.65	9.60	0.70	1.59	2.69	3.09
	RwoT	3.87	2.95	3.08	3.57	-0.11	1.31	3.96	1.58	2.25	2.23	2.97	0.08
	RwT	4.45	5.44	15.69	23.39	10.79	4.25	2.57	6.83	5.39	13.67	3.50	2.94
	Pro	2.07	7.70	8.41	4.76	4.16	14.03	1.83	4.94	8.01	3.11	2.98	8.53
JS	No	84.76	85.06	85.17	81.47	87.97	87.23	55.48	54.83	43.79	50.30	63.42	51.93
	Norm	84.03	83.95	82.65	75.51	83.87	82.89	52.83	57.98	39.18	33.33	41.31	50.63
	RwoT	84.66	89.06	91.97	90.67	90.12	93.14	53.68	66.55	86.34	91.67	78.33	78.55
	RwT	84.57	18.90	34.22	34.51	11.94	51.58	51.29	12.83	13.92	18.51	6.33	21.35
	Pro	84.76	34.95	17.73	16.70	12.91	50.75	53.09	31.67	12.49	9.57	12.77	31.31
MMCA	No	89.28	87.38	80.24	62.20	84.60	84.13	87.64	86.49	78.67	68.04	85.48	81.48
	Norm	89.56	86.74	75.75	49.00	75.83	78.66	87.34	86.00	71.64	52.67	75.78	74.84
	RwoT	89.51	91.56	93.18	85.51	90.15	91.21	88.65	86.23	92.82	93.21	90.68	91.47
	RwT	89.26	67.39	71.89	46.62	55.67	80.99	86.84	53.52	56.59	50.97	39.24	82.23
	Pro	89.66	48.15	25.66	22.94	18.36	70.85	87.60	44.85	14.97	14.26	14.73	28.31
EXJS	No	82.63	79.95	77.42	75.72	84.44	85.21	48.80	46.36	43.13	46.69	51.04	46.62
	Norm	84.50	85.89	80.16	61.33	80.97	82.09	49.05	49.68	47.90	40.74	44.09	48.80
	RwoT	85.05	87.67	90.28	90.26	90.65	92.70	50.46	62.69	87.22	92.45	79.75	77.35
	RwT	85.48	30.12	42.47	41.39	25.47	48.73	47.32	12.87	21.08	28.24	14.00	24.28
	Pro	84.70	37.49	11.43	8.32	6.15	64.89	47.81	23.47	23.32	4.14	12.23	37.59

Table B.3: Percentage improvement of policies over LBT for each rendezvous strategy (2 nodes, 3 BL TSs)

		7 channels					14 channels				
		LOW	LONG	HIGH	INTER	MIXPR	LOW	LONG	HIGH	INTER	MIXPR
EMCA	Norm	11.04	-13.51	-40.92	-58.03	-6.17	-2.59	-0.66	-29.73	-39.98	-12.08
	RwoT	30.94	67.28	77.06	39.23	55.41	18.21	75.72	86.33	45.70	57.13
	RwT	50.12	80.65	82.89	54.50	67.16	32.96	82.20	90.95	53.66	67.00
	Pro	25.71	67.54	80.51	42.97	55.76	23.24	72.18	90.07	43.29	52.83
RAND	Norm	-4.63	-11.45	-34.22	-57.94	-9.63	-13.59	-16.53	-68.79	-74.40	-30.03
	RwoT	26.92	65.94	77.18	44.11	51.22	14.59	76.10	83.34	41.82	56.50
	RwT	46.11	77.49	81.43	51.54	66.14	33.33	77.63	89.75	47.15	60.88
	Pro	28.39	66.17	80.58	45.74	55.72	21.82	70.72	89.64	36.62	45.25
JS	Norm	3.49	-0.06	2.38	-11.58	24.74	6.77	4.94	-27.87	-40.66	-29.04
	RwoT	44.41	48.29	53.93	34.49	11.32	3.04	15.95	17.79	3.34	-3.09
	RwT	77.40	88.52	89.33	84.30	79.61	58.06	85.72	91.61	71.57	78.35
	Pro	68.88	83.44	90.65	80.80	72.30	53.31	79.69	92.11	65.56	71.23
MMCA	Norm	-2.81	-10.18	-18.48	5.78	17.08	-10.66	-2.19	-35.58	17.01	-28.18
	RwoT	46.66	28.94	39.52	-3.83	68.92	2.85	46.21	53.98	66.62	33.31
	RwT	73.85	83.62	82.55	69.34	64.85	58.11	83.07	85.67	79.15	57.50
	Pro	75.23	81.61	85.34	71.34	69.31	59.33	83.21	90.12	76.34	79.95
EXJS	Norm	-38.97	-55.47	-27.89	-28.38	-8.20	5.50	-38.53	-29.79	-118.02	-15.24
	RwoT	-1.06	-32.86	39.69	9.15	-21.70	-16.22	-34.24	9.05	-65.60	-17.75
	RwT	66.55	80.37	83.69	77.86	71.51	59.46	82.75	91.05	52.43	73.24
	Pro	49.01	74.62	84.96	77.73	67.14	44.37	73.74	92.56	48.90	56.84

Table B.4: Percentage improvement of policies over LBT for each rendezvous strategy (10 nodes, 3 BL TSs)

		7 channels					14 channels				
		LOW	LONG	HIGH	INTER	MIXPR	LOW	LONG	HIGH	INTER	MIXPR
EMCA	Norm	-10.63	-24.36	-61.85	-59.54	-20.31	-5.85	-18.25	-57.21	-63.39	-19.87
	RwoT	31.91	67.74	70.50	41.96	55.99	26.78	77.82	86.83	44.54	57.83
	RwT	40.09	75.76	77.51	48.41	58.68	29.98	80.31	88.63	48.56	61.98
	Pro	31.38	67.77	76.11	47.39	40.02	26.25	73.91	87.47	43.90	43.77
RAND	Norm	-6.68	-22.00	-61.21	-55.62	-20.16	-15.57	-17.31	-55.38	-55.98	-21.78
	RwoT	32.80	67.59	70.56	43.67	55.86	26.57	77.65	86.90	46.90	58.45
	RwT	39.31	72.00	71.75	43.81	57.28	25.83	79.50	87.19	50.48	61.43
	Pro	28.79	65.73	75.87	46.66	30.94	23.43	72.05	87.42	46.28	39.47
JS	Norm	-2.99	-6.31	-22.49	-18.98	10.25	-13.78	-9.28	-17.19	-1.85	-16.71
	RwoT	7.03	40.40	41.37	29.40	18.09	1.12	8.77	21.49	6.38	5.50
	RwT	88.96	94.53	93.64	92.96	89.11	63.72	87.14	93.07	79.91	76.76
	Pro	84.24	94.19	94.69	92.74	84.45	51.25	83.24	93.11	76.47	60.65
MMCA	Norm	-5.30	-1.34	-19.95	-1.64	10.54	-2.17	11.09	-6.14	2.06	11.74
	RwoT	-1.82	6.47	23.05	9.31	20.58	28.14	34.09	38.03	13.62	8.42
	RwT	76.81	82.96	84.07	82.08	65.50	79.65	90.33	92.59	87.71	60.36
	Pro	83.30	91.43	88.28	90.08	67.35	81.93	93.45	95.33	90.45	85.47
EXJS	Norm	-57.22	-41.59	-1.61	-30.45	0.66	-12.84	-29.07	-41.41	-43.08	-24.98
	RwoT	-10.72	25.05	26.47	3.47	10.86	-5.27	1.31	7.04	-34.08	0.63
	RwT	82.81	90.48	90.69	89.23	88.08	56.89	85.81	91.56	70.72	73.20
	Pro	77.99	91.78	93.68	91.28	74.74	48.30	80.65	93.03	68.71	51.90

Table B.5: Average HI for single-hop (2 nodes and 3 BL timeslots)

		7 channels						14 channels					
		ZERO	LOW	LONG	HIGH	INTER	MIXPR	ZERO	LOW	LONG	HIGH	INTER	MIXPR
EMCA	No	0.00	0.03	0.04	0.10	0.11	0.05	0.00	0.04	0.06	0.14	0.18	0.09
	Norm	0.00	0.03	0.03	0.06	0.10	0.00	0.00	0.06	0.04	0.06	0.14	0.07
	RwoT	0.00	0.01	0.01	0.00	0.05	0.01	0.00	0.04	0.04	0.06	0.07	0.00
	RwT	0.00	0.01	0.02	0.03	0.09	0.00	0.00	0.02	0.02	0.06	0.08	0.03
	Pro	0.00	0.05	0.01	0.01	0.01	0.02	0.00	0.04	0.04	0.00	0.06	0.04
RAND	No	0.00	0.02	0.03	0.06	0.07	0.05	0.00	0.01	0.08	0.12	0.20	0.05
	Norm	0.00	0.01	0.03	0.08	0.11	0.01	0.00	0.03	0.06	0.19	0.14	0.10
	RwoT	0.00	0.01	0.01	0.04	0.08	0.04	0.00	0.00	0.02	0.01	0.07	0.04
	RwT	0.00	0.04	0.03	0.01	0.08	0.02	0.00	0.05	0.03	0.03	0.06	0.01
	Pro	0.00	0.02	0.01	0.03	0.03	0.02	0.00	0.04	0.01	0.02	0.07	0.05
JS	No	0.00	0.04	0.08	0.26	0.39	0.06	0.00	0.10	0.10	0.31	0.26	0.08
	Norm	0.00	0.04	0.09	0.12	0.18	0.03	0.00	0.08	0.11	0.13	0.21	0.13
	RwoT	0.00	0.04	0.03	0.04	0.10	0.08	0.00	0.05	0.05	0.07	0.17	0.12
	RwT	0.00	0.03	0.03	0.02	0.02	0.03	0.00	0.05	0.02	0.00	0.06	0.03
	Pro	0.00	0.02	0.01	0.03	0.03	0.02	0.00	0.07	0.01	0.00	0.08	0.01
MMCA	No	0.00	0.14	0.16	0.20	0.32	0.15	0.00	0.14	0.07	0.15	0.46	0.18
	Norm	0.00	0.17	0.07	0.16	0.09	0.03	0.00	0.07	0.04	0.13	0.14	0.07
	RwoT	0.00	0.07	0.03	0.06	0.10	0.04	0.00	0.08	0.08	0.10	0.14	0.09
	RwT	0.00	0.02	0.01	0.02	0.07	0.01	0.00	0.03	0.04	0.03	0.07	0.05
	Pro	0.00	0.01	0.02	0.03	0.08	0.04	0.00	0.05	0.02	0.03	0.09	0.01
EXJS	No	0.00	0.04	0.05	0.16	0.23	0.04	0.00	0.07	0.04	0.11	0.24	0.09
	Norm	0.00	0.04	0.05	0.02	0.13	0.05	0.00	0.05	0.06	0.09	0.20	0.04
	RwoT	0.00	0.02	0.06	0.04	0.11	0.08	0.00	0.05	0.07	0.04	0.12	0.05
	RwT	0.00	0.03	0.04	0.00	0.06	0.01	0.00	0.02	0.05	0.05	0.10	0.01
	Pro	0.00	0.03	0.03	0.05	0.06	0.02	0.00	0.03	0.01	0.01	0.11	0.03

Table B.6: Average HI for single-hop (10 nodes and 3 BL timeslots)

		7 channels						14 channels					
		ZERO	LOW	LONG	HIGH	INTER	MIXPR	ZERO	LOW	LONG	HIGH	INTER	MIXPR
EMCA	No	0.00	0.65	0.57	1.59	2.28	0.84	0.00	1.05	1.25	2.50	2.80	1.39
	Norm	0.00	0.52	0.65	1.43	1.71	0.74	0.00	0.92	1.15	2.18	3.22	1.25
	RwoT	0.00	0.43	0.41	0.70	1.09	0.43	0.00	0.84	0.59	0.84	1.78	0.84
	RwT	0.00	0.42	0.24	0.44	0.98	0.42	0.00	0.61	0.47	0.65	2.03	0.60
	Pro	0.00	0.04	0.22	0.54	1.16	0.41	0.00	0.83	0.58	0.83	2.04	0.80
RAND	No	0.00	0.70	0.60	1.65	2.06	0.69	0.00	1.11	1.14	2.40	3.17	1.45
	Norm	0.00	0.49	0.60	1.17	1.66	0.58	0.00	0.99	1.12	2.22	2.81	1.17
	RwoT	0.00	0.47	0.36	0.65	1.04	0.35	0.00	1.02	0.48	0.85	2.36	0.57
	RwT	0.00	0.35	0.33	0.55	1.36	0.34	0.00	0.84	0.48	0.95	2.12	0.62
	Pro	0.00	0.45	0.27	0.54	1.15	0.46	0.00	0.86	0.75	0.87	2.03	0.58
JS	No	0.00	3.82	4.24	7.87	16.47	6.25	0.00	2.57	1.99	5.03	9.03	3.09
	Norm	0.00	2.87	2.48	3.56	7.88	2.91	0.00	2.15	1.96	3.16	4.49	2.06
	RwoT	0.00	2.63	2.04	3.02	6.32	3.03	0.00	1.92	1.74	2.52	4.31	1.77
	RwT	0.00	0.43	0.36	0.56	1.13	0.76	0.00	0.96	0.45	0.86	1.76	0.55
	Pro	0.00	0.66	0.41	0.56	1.20	0.83	0.00	1.00	0.75	0.84	2.44	1.05
MMCA	No	0.00	4.27	3.51	4.04	13.08	4.51	0.00	7.67	5.77	7.99	20.93	7.49
	Norm	0.00	3.56	2.47	2.26	6.27	2.68	0.00	6.46	3.84	4.35	11.35	4.23
	RwoT	0.00	4.58	4.24	3.22	9.40	3.80	0.00	5.55	5.72	5.67	16.73	6.75
	RwT	0.00	1.11	0.66	0.84	2.22	1.65	0.00	1.64	1.04	1.42	2.96	2.89
	Pro	0.00	0.79	0.30	0.68	1.43	0.96	0.00	1.54	0.64	0.92	2.04	1.01
EXJS	No	0.00	2.95	4.17	5.40	12.85	5.53	0.00	2.20	1.86	4.22	6.87	2.66
	Norm	0.00	3.21	2.35	2.96	6.40	2.76	0.00	1.96	2.07	3.45	4.03	1.86
	RwoT	0.00	2.24	1.30	2.94	5.86	2.68	0.00	1.83	1.42	3.00	4.14	1.55
	RwT	0.00	0.58	0.47	0.73	1.25	0.52	0.00	0.83	0.51	0.81	2.21	0.66
	Pro	0.00	0.75	0.42	0.59	1.19	1.22	0.00	1.15	0.86	0.95	2.42	1.01

Table B.7: Average TTR for single-hop (2 nodes and 10 BL timeslots)

		7 channels						14 channels					
		ZERO	LOW	LONG	HIGH	INTER	MIXPR	ZERO	LOW	LONG	HIGH	INTER	MIXPR
EMCA	No	6.82	8.79	15.25	35.09	10.96	11.19	11.62	13.51	28.58	55.36	18.71	20.69
	Norm	6.66	10.39	18.34	64.42	21.60	16.76	11.64	15.48	36.86	90.46	38.24	28.03
	RwoT	6.41	5.81	6.33	17.96	9.74	6.19	11.48	10.88	7.13	15.29	11.27	8.26
	RwT	6.09	4.82	4.64	17.51	8.48	4.39	11.08	10.80	5.85	9.39	9.64	7.45
	Pro	6.57	6.45	6.97	16.19	11.28	6.27	11.16	11.89	8.95	13.85	11.98	9.41
RAND	No	7.82	9.51	16.94	38.16	12.22	12.67	12.47	14.94	29.71	58.42	19.06	21.68
	Norm	7.38	12.93	23.77	83.27	23.98	18.73	13.25	18.44	38.05	109.24	39.93	30.37
	RwoT	7.29	6.28	6.57	23.34	11.23	6.68	12.96	12.01	8.85	18.59	12.21	9.57
	RwT	7.10	5.03	8.64	20.35	10.75	5.48	12.56	11.30	7.74	14.95	11.27	8.32
	Pro	7.58	7.35	8.27	17.86	12.36	9.06	12.55	12.25	10.58	17.75	14.31	13.47
JS	No	15.80	25.84	40.03	97.68	40.32	33.39	23.09	27.33	44.96	83.81	33.28	40.43
	Norm	14.53	26.86	55.61	112.23	46.23	33.38	22.81	27.86	59.49	134.73	51.26	43.94
	RwoT	15.03	28.35	27.94	67.85	40.21	24.05	21.57	28.24	40.66	84.56	41.86	39.55
	RwT	14.79	6.53	6.15	23.83	11.03	5.78	22.39	12.47	8.96	18.90	11.31	9.75
	Pro	14.54	7.93	9.40	20.04	13.09	13.66	21.18	14.81	11.11	19.44	18.56	14.47
MMCA	No	26.09	37.42	43.23	70.12	30.77	38.87	40.57	41.01	54.66	74.21	53.60	61.61
	Norm	23.97	43.66	48.79	93.06	56.85	46.67	42.71	52.93	61.53	143.78	73.85	76.34
	RwoT	23.02	21.53	36.98	60.29	36.91	24.42	39.29	29.13	15.11	46.55	35.41	47.27
	RwT	23.38	10.86	9.44	26.11	17.45	11.27	42.82	12.86	10.47	21.17	14.68	13.61
	Pro	23.07	8.94	10.25	21.18	14.05	15.83	46.83	16.04	12.42	19.43	16.61	16.29
EXJS	No	13.35	17.63	22.38	63.48	32.74	22.15	18.60	23.80	34.99	88.93	23.23	28.22
	Norm	13.69	21.87	30.34	109.02	40.84	35.64	18.46	29.16	50.23	134.82	61.91	38.25
	RwoT	13.89	18.30	23.39	60.27	29.80	21.10	17.96	20.91	40.66	99.10	42.87	26.93
	RwT	12.79	6.87	7.27	26.35	9.31	5.27	18.74	12.17	8.15	18.86	14.07	8.05
	Pro	13.71	7.99	8.07	18.08	12.88	10.68	17.90	12.82	10.68	17.06	14.50	13.48

Table B.8: Average TTR for single-hop (10 nodes and 10 BL timeslots)

		7 channels						14 channels					
		ZERO	LOW	LONG	HIGH	INTER	MIXPR	ZERO	LOW	LONG	HIGH	INTER	MIXPR
EMCA	No	31.04	37.73	62.49	127.40	46.42	53.03	57.77	68.16	125.35	216.32	77.68	94.57
	Norm	30.08	47.90	100.45	281.01	102.70	77.23	57.75	78.06	168.83	413.02	148.04	113.49
	RwoT	29.62	28.04	33.95	117.62	57.62	39.78	57.60	49.64	35.29	88.09	56.91	35.49
	RwT	28.95	23.84	28.97	98.45	49.48	36.17	55.10	46.69	31.01	79.77	54.41	33.15
	Pro	29.91	28.58	34.44	100.88	57.73	61.80	56.84	51.91	39.19	84.16	60.83	61.69
RAND	No	32.01	39.39	64.17	132.39	47.77	53.58	60.68	69.06	127.24	222.39	83.62	96.05
	Norm	30.50	47.68	104.77	287.44	107.34	82.43	58.67	80.56	185.26	448.68	165.86	118.58
	RwoT	29.64	28.76	36.53	119.11	61.53	42.30	58.77	50.36	37.00	89.55	58.30	36.77
	RwT	29.99	27.11	30.83	112.94	56.48	38.04	56.86	48.18	35.74	86.43	56.74	34.99
	Pro	30.47	30.39	36.90	106.71	59.73	66.57	57.11	54.77	42.17	86.33	62.35	69.59
JS	No	203.65	252.48	421.37	687.41	386.01	415.42	129.77	150.91	223.01	435.24	212.33	196.72
	Norm	195.63	334.00	521.42	953.77	520.22	417.10	132.73	156.50	261.54	582.53	234.87	202.24
	RwoT	200.86	195.28	292.21	536.57	345.30	378.61	135.52	140.90	212.44	429.55	206.70	185.45
	RwT	196.11	31.71	40.38	119.02	63.80	60.38	131.10	50.52	38.47	103.22	57.64	48.56
	Pro	200.24	35.19	39.40	110.96	63.73	112.58	132.49	63.28	44.17	90.87	65.94	98.99
MMCA	No	289.60	298.90	316.23	337.05	301.45	334.19	467.49	504.49	587.76	676.91	535.01	510.53
	Norm	283.30	288.78	319.37	480.31	327.35	350.16	468.06	531.66	575.61	696.67	522.08	518.11
	RwoT	271.28	282.15	282.41	371.36	281.54	276.44	473.64	386.97	553.34	511.90	436.70	347.69
	RwT	278.76	56.75	65.54	147.08	76.15	120.71	417.32	76.02	57.97	102.91	71.75	86.43
	Pro	280.72	36.83	42.09	113.99	68.44	160.62	471.88	64.09	45.74	96.46	61.48	210.50
EXJS	No	178.75	188.17	276.70	524.78	298.35	358.61	112.84	127.07	220.41	405.79	158.67	177.16
	Norm	179.90	302.51	447.00	726.61	467.13	405.75	117.47	135.18	279.52	568.08	264.34	229.51
	RwoT	182.58	186.00	259.63	482.31	322.58	347.35	109.97	141.74	241.48	516.81	212.75	191.08
	RwT	186.10	34.41	43.13	141.59	68.86	68.94	109.59	54.13	39.06	98.57	60.74	53.69
	Pro	181.55	36.66	37.88	108.59	61.03	124.79	112.15	61.74	42.70	88.65	63.73	102.29

Table B.9: Percentage improvement of EMCA over other rendezvous strategies in terms of ATTR (2 nodes, 10 BL TS)

		7 channels						14 channels					
		ZERO	LOW	LONG	HIGH	INTER	MIXPR	ZERO	LOW	LONG	HIGH	INTER	MIXPR
RANDOM	No	12.79	7.57	9.98	8.05	10.31	11.68	6.82	9.57	3.80	5.24	1.84	4.57
	Norm	9.76	19.64	22.84	22.64	9.92	10.52	12.15	16.05	3.13	17.19	4.23	7.70
	RwoT	12.07	7.48	3.65	23.05	13.27	7.34	11.42	9.41	19.44	17.75	7.70	13.69
	RwT	14.14	4.15	46.36	13.94	21.10	19.99	11.77	4.45	24.35	37.23	14.45	10.47
	Pro	13.32	12.24	15.72	9.35	8.74	30.79	11.08	2.94	15.41	21.97	16.28	30.14
JS	No	56.83	65.98	61.90	64.08	72.82	66.49	49.68	50.57	36.43	33.95	43.78	48.83
	Norm	54.16	61.32	67.02	42.60	53.28	49.80	48.97	44.44	38.04	32.86	25.40	36.21
	RwoT	57.35	79.51	77.34	73.53	75.78	74.26	46.78	61.47	82.46	81.92	73.08	79.12
	RwT	58.81	26.17	24.62	26.51	23.14	24.02	50.51	13.42	34.64	50.35	14.77	23.55
	Pro	54.81	18.66	25.85	19.21	13.83	54.10	47.31	19.72	19.44	28.76	35.45	34.97
MMCA	No	73.86	76.51	64.72	49.96	64.38	71.21	71.36	67.06	47.71	25.40	65.09	66.42
	Norm	72.22	76.20	62.41	30.78	62.01	64.09	72.75	70.75	40.09	37.08	48.22	63.28
	RwoT	72.15	73.01	82.88	70.21	73.61	74.65	70.78	62.65	52.81	67.15	68.17	82.53
	RwT	73.94	55.59	50.90	32.94	51.40	61.08	74.12	16.01	44.10	55.67	34.34	45.24
	Pro	71.52	27.85	32.00	23.56	19.72	60.39	76.17	25.87	27.94	28.72	27.87	42.23
EXJS	No	48.91	50.14	31.85	44.73	66.52	49.49	37.53	43.24	18.32	37.75	19.46	26.68
	Norm	51.35	52.49	39.55	40.91	47.11	52.97	36.94	46.91	26.62	32.90	38.23	26.72
	RwoT	53.85	68.24	72.94	70.20	67.32	70.67	36.08	47.97	82.46	84.57	73.71	69.33
	RwT	52.37	29.76	36.21	33.54	8.90	16.76	40.87	11.26	28.20	50.24	31.50	7.46
	Pro	52.08	19.27	13.63	10.45	12.42	41.29	37.65	7.25	16.20	18.82	17.38	30.19

Table B.10: Percentage improvement of EMCA over other rendezvous strategies in terms of ATTR (10 nodes, 10 BL TS)

		7 channels						14 channels					
		ZERO	LOW	LONG	HIGH	INTER	MIXPR	ZERO	LOW	LONG	HIGH	INTER	MIXPR
RANDOM	No	3.03	4.21	2.62	3.77	2.83	1.03	4.80	1.30	1.49	2.73	7.10	1.54
	Norm	1.38	-0.46	4.12	2.24	4.32	6.31	1.57	3.10	8.87	7.95	10.74	4.29
	RwoT	0.07	2.50	7.06	1.25	6.35	5.96	1.99	1.43	4.62	1.63	2.38	3.48
	RwT	3.46	12.06	6.03	12.83	12.40	4.92	3.10	3.11	13.22	7.70	4.11	5.28
	Pro	1.84	5.96	6.67	5.46	3.35	7.16	0.47	5.22	7.07	2.51	2.44	11.35
JS	No	84.76	85.06	85.17	81.47	87.97	87.23	55.48	54.83	43.79	50.30	63.42	51.93
	Norm	84.62	85.66	80.74	70.54	80.26	81.48	56.49	50.12	35.45	29.10	36.97	43.88
	RwoT	85.25	85.64	88.38	78.08	83.31	89.49	57.50	64.77	83.39	79.49	72.47	80.86
	RwT	85.24	24.82	28.24	17.28	22.44	40.10	57.98	7.58	19.37	22.72	5.60	31.74
	Pro	85.06	18.78	12.59	9.08	9.41	45.11	57.10	17.97	11.27	7.38	7.75	37.68
MMCA	No	89.28	87.38	80.24	62.20	84.60	84.13	87.64	86.49	78.67	68.04	85.48	81.48
	Norm	89.38	83.41	68.55	41.49	68.63	77.94	87.66	85.32	70.67	40.72	71.64	78.10
	RwoT	89.08	90.06	87.98	68.33	79.53	85.61	87.84	87.17	93.62	82.79	86.97	89.79
	RwT	89.61	57.99	55.79	33.06	35.02	70.04	86.80	38.59	46.50	22.49	24.17	61.65
	Pro	89.35	22.40	18.18	11.50	15.65	61.52	87.95	19.00	14.32	12.75	1.06	70.69
EXJS	No	82.63	79.95	77.42	75.72	84.44	85.21	48.80	46.36	43.13	46.69	51.04	46.62
	Norm	83.28	84.17	77.53	61.33	78.01	80.97	50.84	42.26	39.60	27.30	44.00	50.55
	RwoT	83.78	84.92	86.92	75.61	82.14	88.55	47.62	64.98	85.39	82.96	73.25	81.43
	RwT	84.44	30.73	32.83	30.47	28.15	47.53	49.72	13.75	20.60	19.08	10.42	38.26
	Pro	83.52	22.04	9.08	7.10	5.41	50.48	49.32	15.92	8.22	5.06	4.55	39.69

Table B.11: Percentage improvement of policies over LBT for each rendezvous strategy (2 nodes, 10 BL TSs)

		7 channels					14 channels				
		LOW	LONG	HIGH	INTER	MIXPR	LOW	LONG	HIGH	INTER	MIXPR
EMCA	Norm	-18.20	-20.26	-83.59	-97.08	-49.78	-14.58	-28.97	-63.40	-104.38	-35.48
	RwoT	33.90	58.49	48.82	11.13	44.68	19.47	75.05	72.38	39.76	60.08
	RwT	45.12	69.60	50.09	22.62	60.79	20.05	79.52	83.05	48.48	63.98
	Pro	26.62	54.30	53.86	-2.92	43.97	11.99	68.68	74.98	35.97	54.52
RAND	Norm	-35.96	-40.32	-118.21	-96.24	-47.83	-23.43	-28.07	-86.99	-109.50	-40.08
	RwoT	33.96	61.22	38.84	8.10	47.28	19.61	70.21	68.18	35.94	55.86
	RwT	47.08	48.97	46.67	12.05	56.72	24.34	73.96	74.40	40.89	61.60
	Pro	22.71	51.18	53.20	-1.15	28.49	18.01	64.39	69.62	24.92	37.87
JS	Norm	-3.95	-38.93	-14.90	-14.66	0.02	-1.94	-32.32	-60.76	-54.03	-8.68
	RwoT	-9.73	30.20	30.54	0.27	27.97	-3.33	9.56	-0.89	-25.78	2.18
	RwT	74.71	84.63	75.60	72.63	82.70	54.35	80.08	77.44	66.02	75.89
	Pro	69.31	76.52	79.48	67.53	59.09	45.81	75.29	76.80	44.23	64.21
MMCA	Norm	-16.68	-12.86	-32.72	-84.76	-20.07	-29.07	-12.57	-93.75	-37.78	-23.91
	RwoT	42.46	14.46	14.02	-19.95	37.18	28.97	72.36	37.28	33.94	23.28
	RwT	70.97	78.16	62.76	43.30	71.00	68.64	80.84	71.47	72.61	77.91
	Pro	76.11	76.29	69.79	54.34	59.27	60.89	77.28	73.82	69.01	73.56
EXJS	Norm	-24.04	-35.58	-71.73	-24.74	-60.88	-22.52	-43.56	-51.61	-166.51	-35.54
	RwoT	-3.78	-4.54	5.07	8.98	4.74	12.14	-16.20	-11.44	-84.55	4.57
	RwT	61.04	67.52	58.49	71.57	76.21	48.86	76.70	78.79	39.43	71.46
	Pro	54.68	63.94	71.52	60.66	51.79	46.13	69.48	80.82	37.58	52.23

Table B.12: Percentage improvement of policies over LBT for each rendezvous strategy (10 nodes, 10 BL TSs)

		7 channels					14 channels				
		LOW	LONG	HIGH	INTER	MIXPR	LOW	LONG	HIGH	INTER	MIXPR
EMCA	Norm	-26.95	-60.75	-120.57	-121.24	-45.63	-14.52	-34.69	-90.93	-90.58	-20.01
	RwoT	25.68	45.67	7.68	-24.13	24.99	27.17	71.85	59.28	26.74	62.47
	RwT	36.82	53.63	22.72	-6.59	31.80	31.50	75.26	63.12	29.95	64.95
	Pro	24.25	44.89	20.82	-24.36	-16.54	23.84	68.74	61.09	21.69	34.77
RAND	Norm	-21.05	-63.27	-117.12	-124.70	-53.84	-16.65	-45.60	-101.75	-98.35	-23.46
	RwoT	26.99	43.07	10.03	-28.80	21.05	27.08	70.92	59.73	30.28	61.72
	RwT	31.18	51.95	14.69	-18.24	29.00	30.23	71.91	61.14	32.14	63.57
	Pro	22.85	42.50	19.40	-25.04	-24.24	20.69	66.86	61.18	25.44	27.55
JS	Norm	-32.29	-23.74	-38.75	-34.77	-0.40	-3.70	-17.28	-33.84	-10.62	-2.81
	RwoT	22.66	30.65	21.94	10.55	8.86	6.63	4.74	1.31	2.65	5.73
	RwT	87.44	90.42	82.69	83.47	85.46	66.53	82.75	76.29	72.85	75.32
	Pro	86.06	90.65	83.86	83.49	72.90	58.07	80.19	79.12	68.94	49.68
MMCA	Norm	3.39	-0.99	-42.50	-8.59	-4.78	-5.39	2.07	-2.92	2.42	-1.48
	RwoT	5.60	10.69	-10.18	6.60	17.28	23.30	5.86	24.38	18.38	31.90
	RwT	81.01	79.27	56.36	74.74	63.88	84.93	90.14	84.80	86.59	83.07
	Pro	87.68	86.69	66.18	77.30	51.94	87.30	92.22	85.75	88.51	58.77
EXJS	Norm	-60.76	-61.55	-38.46	-56.57	-13.14	-6.38	-26.81	-39.99	-66.60	-29.55
	RwoT	1.15	6.17	8.09	-8.12	3.14	-11.54	-9.56	-27.36	-34.08	-7.86
	RwT	81.71	84.41	73.02	76.92	80.78	57.40	82.28	75.71	61.72	69.70
	Pro	80.52	86.31	79.31	79.54	65.20	51.41	80.63	78.15	59.83	42.26

Table B.13: Average HI for single-hop (2 nodes and 10 BL timeslots)

		7 channels						14 channels					
		ZERO	LOW	LONG	HIGH	INTER	MIXPR	ZERO	LOW	LONG	HIGH	INTER	MIXPR
EMCA	No	0.00	0.03	0.04	0.10	0.11	0.05	0.00	0.04	0.06	0.14	0.18	0.09
	Norm	0.00	0.03	0.01	0.05	0.11	0.05	0.00	0.05	0.05	0.08	0.15	0.03
	RwoT	0.00	0.00	0.01	0.05	0.01	0.00	0.00	0.03	0.01	0.04	0.07	0.03
	RwT	0.00	0.01	0.01	0.00	0.02	0.03	0.00	0.02	0.04	0.03	0.10	0.03
	Pro	0.00	0.02	0.01	0.00	0.07	0.02	0.00	0.06	0.03	0.03	0.08	0.02
RAND	No	0.00	0.02	0.03	0.06	0.07	0.05	0.00	0.01	0.08	0.12	0.20	0.05
	Norm	0.00	0.03	0.03	0.10	0.07	0.02	0.00	0.08	0.06	0.16	0.16	0.06
	RwoT	0.00	0.01	0.02	0.04	0.05	0.01	0.00	0.11	0.01	0.00	0.08	0.01
	RwT	0.00	0.00	0.03	0.01	0.04	0.01	0.00	0.02	0.03	0.03	0.04	0.05
	Pro	0.00	0.03	0.02	0.08	0.04	0.01	0.00	0.03	0.04	0.03	0.09	0.03
JS	No	0.00	0.04	0.08	0.26	0.39	0.06	0.00	0.10	0.10	0.31	0.26	0.08
	Norm	0.00	0.02	0.02	0.05	0.12	0.01	0.00	0.02	0.04	0.08	0.18	0.04
	RwoT	0.00	0.04	0.01	0.02	0.08	0.02	0.00	0.07	0.05	0.06	0.06	0.04
	RwT	0.00	0.00	0.01	0.03	0.07	0.01	0.00	0.01	0.02	0.03	0.10	0.04
	Pro	0.00	0.00	0.04	0.03	0.05	0.03	0.00	0.06	0.03	0.09	0.14	0.02
MMCA	No	0.00	0.14	0.16	0.20	0.32	0.15	0.00	0.14	0.07	0.15	0.46	0.18
	Norm	0.00	0.06	0.05	0.07	0.11	0.05	0.00	0.06	0.03	0.14	0.26	0.12
	RwoT	0.00	0.03	0.04	0.03	0.09	0.01	0.00	0.12	0.03	0.06	0.17	0.08
	RwT	0.00	0.03	0.01	0.02	0.05	0.02	0.00	0.03	0.03	0.02	0.02	0.05
	Pro	0.00	0.02	0.02	0.01	0.04	0.01	0.00	0.03	0.04	0.04	0.13	0.02
EXJS	No	0.00	0.04	0.05	0.16	0.23	0.04	0.00	0.07	0.04	0.11	0.24	0.09
	Norm	0.00	0.04	0.03	0.05	0.10	0.02	0.00	0.02	0.04	0.08	0.12	0.07
	RwoT	0.00	0.05	0.04	0.10	0.10	0.03	0.00	0.04	0.05	0.07	0.14	0.01
	RwT	0.00	0.02	0.02	0.09	0.01	0.00	0.00	0.03	0.02	0.07	0.09	0.00
	Pro	0.00	0.03	0.02	0.03	0.06	0.02	0.00	0.03	0.03	0.02	0.19	0.03

Table B.14: Average HI for single-hop (10 nodes and 10 BL timeslots)

		7 channels						14 channels					
		ZERO	LOW	LONG	HIGH	INTER	MIXPR	ZERO	LOW	LONG	HIGH	INTER	MIXPR
EMCA	No	0.00	0.65	0.57	1.59	2.28	0.84	0.00	1.05	1.25	2.50	2.80	1.39
	Norm	0.00	0.48	0.45	0.99	1.27	0.64	0.00	0.97	1.11	2.58	3.04	0.90
	RwoT	0.00	0.32	0.34	0.84	1.17	0.33	0.00	0.90	0.33	1.10	2.12	0.49
	RwT	0.00	0.34	0.32	0.90	1.10	0.30	0.00	0.81	0.46	1.09	1.83	0.50
	Pro	0.00	0.42	0.57	0.92	1.48	0.57	0.00	0.95	0.68	1.37	2.32	0.69
RAND	No	0.00	0.70	0.60	1.65	2.06	0.69	0.00	1.11	1.14	2.40	3.17	1.45
	Norm	0.00	0.55	0.47	0.85	1.32	0.58	0.00	0.85	1.00	2.25	2.63	0.92
	RwoT	0.00	0.32	0.27	0.86	1.35	0.42	0.00	0.92	0.59	1.24	2.30	0.37
	RwT	0.00	0.47	0.41	0.80	1.25	0.33	0.00	0.85	0.63	1.39	2.14	0.38
	Pro	0.00	0.48	0.57	0.79	1.43	0.52	0.00	0.95	0.73	1.22	2.59	0.76
JS	No	0.00	3.82	4.24	7.87	16.47	6.25	0.00	2.57	1.99	5.03	9.03	3.09
	Norm	0.00	2.56	2.31	2.78	5.43	2.25	0.00	1.52	1.38	2.88	3.75	1.34
	RwoT	0.00	2.00	1.48	2.14	4.81	2.09	0.00	1.50	1.35	2.53	3.22	1.31
	RwT	0.00	0.48	0.49	0.89	1.09	0.45	0.00	0.85	0.66	1.17	2.34	0.73
	Pro	0.00	0.57	0.47	0.85	1.42	0.81	0.00	1.09	0.75	1.15	2.44	0.92
MMCA	No	0.00	4.27	3.51	4.04	13.08	4.51	0.00	7.67	5.77	7.99	20.93	7.49
	Norm	0.00	2.53	1.55	1.75	4.44	2.30	0.00	6.01	3.61	3.79	9.86	4.12
	RwoT	0.00	3.84	2.46	2.06	4.84	2.09	0.00	5.66	7.45	5.08	13.21	4.46
	RwT	0.00	0.68	0.58	0.91	1.52	1.01	0.00	0.97	0.82	1.30	2.58	1.09
	Pro	0.00	0.60	0.45	0.82	1.57	1.34	0.00	0.99	0.62	1.21	2.46	1.97
EXJS	No	0.00	2.95	4.17	5.40	12.85	5.53	0.00	2.20	1.86	4.22	6.87	2.66
	Norm	0.00	2.63	2.04	3.17	5.28	2.30	0.00	1.25	1.40	2.20	3.47	1.27
	RwoT	0.00	1.81	1.63	2.08	4.53	2.33	0.00	1.53	1.14	2.37	3.30	1.27
	RwT	0.00	0.41	0.48	0.98	1.34	0.59	0.00	1.01	0.41	1.11	1.99	0.53
	Pro	0.00	0.61	0.48	0.86	1.34	1.04	0.00	1.04	0.72	1.39	2.70	0.81

B.2 Chapter 7

Table B.15: Percentage improvement of multihop EMCA over other rendezvous strategies in terms of ATTR (2 nodes, 3 BL TSs)

		7 channels						14 channels					
		ZERO	LOW	LONG	HIGH	INTER	MIXPR	ZERO	LOW	LONG	HIGH	INTER	MIXPR
RAND	No	2.47	3.17	2.35	1.30	1.04	1.97	3.75	3.36	1.77	1.84	5.84	7.58
	Norm	3.48	2.37	3.12	1.41	0.83	2.49	2.72	5.18	2.27	1.48	3.63	3.25
	RwoT	3.91	2.82	2.06	6.11	3.59	2.22	2.40	1.11	1.20	0.56	1.67	2.13
	RwT	2.20	1.01	4.88	10.40	1.84	2.80	1.96	3.74	1.72	3.52	2.03	0.69
	Pro	2.37	6.79	3.96	4.54	2.53	5.06	2.49	6.23	8.17	5.08	6.53	6.71
JS	No	31.42	30.82	37.37	38.32	26.41	30.40	24.50	27.55	14.06	17.50	29.07	26.42
	Norm	31.22	26.42	32.56	44.23	28.20	38.62	24.64	31.74	24.06	24.60	27.39	24.64
	RwoT	32.45	25.43	51.97	60.09	54.29	47.60	25.06	34.84	65.11	76.31	56.51	50.37
	RwT	29.10	7.38	13.69	17.47	4.45	12.65	25.97	11.84	9.55	9.07	7.15	8.97
	Pro	32.03	10.80	6.66	7.61	4.51	10.93	24.35	13.31	6.18	4.47	5.40	9.91
MMCA	No	33.89	33.13	20.47	25.11	24.55	34.60	37.08	36.44	17.20	24.94	37.64	35.24
	Norm	33.72	28.25	20.10	19.40	24.45	33.39	36.60	37.51	29.53	22.84	32.81	25.58
	RwoT	34.68	31.40	32.96	36.72	37.46	52.69	36.72	38.85	50.72	54.94	34.09	33.70
	RwT	35.26	15.99	18.60	22.16	9.46	19.69	35.69	14.45	15.08	14.80	12.28	28.28
	Pro	34.11	12.35	5.47	7.66	3.02	29.78	36.32	4.05	6.28	7.58	5.13	28.41
EXJS	No	25.40	31.65	37.85	33.27	38.11	31.29	28.23	30.42	28.44	25.95	29.54	33.19
	Norm	25.35	35.48	42.14	42.38	38.84	46.48	28.50	26.46	31.03	29.16	39.33	35.85
	RwoT	27.16	36.10	45.55	66.90	44.26	45.78	28.29	40.01	68.33	81.03	59.19	60.76
	RwT	24.88	7.66	14.15	18.03	3.71	11.59	29.16	9.62	8.21	13.31	9.17	12.09
	Pro	26.94	15.01	6.47	8.95	4.07	13.96	27.43	16.22	11.84	3.26	6.77	17.61

Table B.16: Percentage improvement of multihop EMCA over other rendezvous strategies in terms of ATTR (10 nodes, 3 BL TSs)

		7 channels						14 channels					
		ZERO	LOW	LONG	HIGH	INTER	MIXPR	ZERO	LOW	LONG	HIGH	INTER	MIXPR
RAND	No	1.77	1.81	1.22	0.96	1.92	4.93	1.73	5.39	2.73	1.45	1.79	1.23
	Norm	1.23	2.06	5.08	12.83	5.21	1.85	3.51	2.10	2.18	2.02	3.12	2.74
	RwoT	0.42	1.80	1.54	1.76	0.82	1.98	3.91	1.60	0.85	1.83	1.13	2.33
	RwT	-0.03	0.49	1.99	10.27	3.50	3.46	3.33	5.72	3.09	6.72	2.18	3.29
	Pro	0.27	1.71	2.70	4.78	2.56	4.46	4.45	2.73	4.07	4.25	8.46	5.36
JS	No	31.46	30.18	23.48	23.28	27.58	27.25	29.98	21.05	26.03	22.79	20.96	26.78
	Norm	32.08	25.54	28.85	36.25	27.29	26.58	30.04	28.28	33.96	18.15	27.81	30.20
	RwoT	30.48	37.15	50.39	60.39	46.45	56.94	30.10	36.98	65.49	79.19	55.76	57.32
	RwT	29.01	19.09	16.26	27.70	16.59	23.94	26.82	15.32	17.99	15.93	8.96	22.19
	Pro	29.19	16.53	13.89	7.37	5.60	22.81	25.41	11.57	8.75	5.25	9.94	21.78
MMCA	No	28.39	23.34	16.67	14.88	12.97	37.54	33.27	27.37	27.98	19.79	24.37	34.83
	Norm	28.82	20.27	25.22	20.42	17.25	25.35	33.00	25.46	19.30	13.53	14.68	33.08
	RwoT	28.18	32.01	38.72	36.84	21.45	32.03	34.48	24.65	27.11	38.41	36.44	34.75
	RwT	26.61	22.17	30.10	27.93	18.19	22.79	35.24	12.20	20.71	18.05	12.86	22.71
	Pro	27.52	9.67	5.94	7.24	5.52	19.43	33.06	8.65	3.94	4.31	6.86	9.84
EXJS	No	36.26	34.66	32.93	29.08	37.61	33.41	38.33	31.15	39.61	27.10	32.52	32.14
	Norm	35.55	36.52	34.00	36.76	30.73	36.02	37.85	36.64	31.73	22.05	35.39	37.58
	RwoT	35.61	48.57	54.67	60.75	52.19	53.19	38.09	44.04	67.48	79.69	61.16	61.79
	RwT	35.92	21.76	13.35	24.93	12.75	18.03	37.97	14.36	14.10	18.80	7.42	24.56
	Pro	35.93	20.79	10.07	6.98	6.62	28.08	36.89	19.06	21.13	6.72	9.55	35.45

Table B.17: Average HI for multihop (2 nodes and 3 BL timeslots)

		7 channels						14 channels					
		ZERO	LOW	LONG	HIGH	INTER	MIXPR	ZERO	LOW	LONG	HIGH	INTER	MIXPR
EMCA	No	0.00	0.16	0.19	0.33	0.77	0.26	0.00	0.32	0.32	0.52	0.77	0.34
	Norm	0.00	0.21	0.27	0.30	0.40	0.16	0.00	0.25	0.20	0.48	0.58	0.15
	RwoT	0.00	0.26	0.13	0.28	0.55	0.22	0.00	0.23	0.21	0.34	0.87	0.26
	RwT	0.00	0.25	0.24	0.15	0.52	0.26	0.00	0.22	0.22	0.32	0.73	0.29
	Pro	0.00	0.22	0.11	0.32	0.53	0.15	0.00	0.28	0.32	0.31	0.81	0.21
RAND	No	0.00	0.17	0.14	0.25	0.74	0.32	0.00	0.33	0.35	0.42	0.92	0.33
	Norm	0.00	0.15	0.12	0.27	0.42	0.19	0.00	0.33	0.21	0.38	0.69	0.23
	RwoT	0.00	0.17	0.25	0.28	0.58	0.18	0.00	0.26	0.27	0.30	0.76	0.27
	RwT	0.00	0.24	0.19	0.25	0.73	0.23	0.00	0.37	0.23	0.32	0.72	0.25
	Pro	0.00	0.20	0.18	0.29	0.51	0.16	0.00	0.36	0.33	0.51	0.76	0.21
JS	No	0.00	0.21	0.21	0.53	0.91	0.37	0.00	0.35	0.34	0.54	0.91	0.44
	Norm	0.00	0.23	0.30	0.44	0.67	0.27	0.00	0.31	0.26	0.58	0.72	0.21
	RwoT	0.00	0.17	0.21	0.22	0.58	0.20	0.00	0.40	0.33	0.42	0.82	0.26
	RwT	0.00	0.27	0.14	0.20	0.57	0.23	0.00	0.33	0.21	0.39	0.76	0.27
	Pro	0.00	0.17	0.14	0.30	0.57	0.16	0.00	0.30	0.33	0.36	0.94	0.15
MMCA	No	0.00	0.29	0.17	0.47	0.80	0.39	0.00	0.38	0.29	0.59	1.18	0.54
	Norm	0.00	0.22	0.13	0.29	0.55	0.18	0.00	0.45	0.17	0.56	0.89	0.20
	RwoT	0.00	0.24	0.27	0.29	0.73	0.43	0.00	0.43	0.31	0.56	1.16	0.47
	RwT	0.00	0.24	0.24	0.14	0.60	0.31	0.00	0.28	0.27	0.39	0.75	0.35
	Pro	0.00	0.33	0.18	0.28	0.51	0.29	0.00	0.33	0.24	0.37	0.83	0.29
EXJS	No	0.00	0.33	0.22	0.46	1.00	0.35	0.00	0.42	0.41	0.61	1.34	0.45
	Norm	0.00	0.22	0.24	0.26	0.66	0.20	0.00	0.28	0.33	0.53	0.69	0.35
	RwoT	0.00	0.29	0.26	0.21	0.43	0.23	0.00	0.35	0.29	0.51	0.86	0.34
	RwT	0.00	0.21	0.14	0.27	0.42	0.16	0.00	0.31	0.22	0.31	0.85	0.23
	Pro	0.00	0.37	0.23	0.34	0.54	0.15	0.00	0.26	0.18	0.33	0.63	0.15

Table B.18: Average HI for multihop (10 nodes and 3 BL timeslots)

		7 channels						14 channels					
		ZERO	LOW	LONG	HIGH	INTER	MIXPR	ZERO	LOW	LONG	HIGH	INTER	MIXPR
EMCA	No	0.00	0.96	0.80	1.48	2.95	1.09	0.00	1.36	1.21	1.96	4.04	1.29
	Norm	0.00	0.90	0.81	1.22	2.08	0.88	0.00	1.13	1.01	1.92	3.22	1.00
	RwoT	0.00	0.78	0.64	1.02	2.08	0.66	0.00	1.11	0.87	1.63	3.20	1.10
	RwT	0.00	0.93	0.81	0.98	1.93	0.61	0.00	1.26	0.95	1.30	3.29	0.95
	Pro	0.00	1.04	0.83	1.21	2.65	0.81	0.00	1.05	0.91	1.52	3.44	1.03
RAND	No	0.00	0.87	1.09	1.44	2.66	1.02	0.00	1.52	1.17	2.29	3.97	1.60
	Norm	0.00	1.04	0.77	1.16	2.17	0.82	0.00	1.24	1.03	1.86	3.17	1.21
	RwoT	0.00	0.88	0.81	1.18	2.12	0.82	0.00	1.28	1.04	1.75	3.26	0.93
	RwT	0.00	0.90	0.75	1.08	2.21	0.80	0.00	1.20	1.13	1.56	3.27	1.22
	Pro	0.00	0.86	0.78	1.05	2.36	0.69	0.00	1.31	1.19	1.65	3.68	0.89
JS	No	0.00	0.82	1.12	1.86	4.05	1.11	0.00	1.78	1.59	2.49	5.20	2.13
	Norm	0.00	1.26	0.96	1.43	2.40	0.95	0.00	1.37	1.50	2.00	3.63	1.35
	RwoT	0.00	0.93	0.77	1.23	2.33	1.10	0.00	1.40	1.17	1.86	3.14	1.11
	RwT	0.00	0.90	0.71	0.98	2.24	0.85	0.00	1.45	0.93	1.43	2.69	0.91
	Pro	0.00	0.89	0.89	1.29	2.55	0.78	0.00	1.19	1.08	1.80	3.27	1.06
MMCA	No	0.00	0.99	0.76	1.08	2.45	0.99	0.00	1.77	1.70	2.79	5.64	2.09
	Norm	0.00	0.98	0.83	1.24	2.37	0.99	0.00	1.69	1.14	2.36	3.23	1.68
	RwoT	0.00	1.29	1.07	1.63	2.40	0.87	0.00	1.79	1.13	2.06	4.63	1.65
	RwT	0.00	0.95	0.95	1.35	2.71	1.06	0.00	1.25	1.10	1.68	3.41	1.13
	Pro	0.00	0.88	0.78	1.06	2.17	0.69	0.00	1.30	0.99	1.37	3.29	0.92
EXJS	No	0.00	1.13	1.27	2.01	4.62	1.58	0.00	1.97	1.78	3.13	6.35	2.14
	Norm	0.00	1.14	0.87	1.45	2.24	0.93	0.00	1.42	1.14	1.93	3.96	1.60
	RwoT	0.00	1.03	0.87	1.11	2.39	0.93	0.00	1.59	1.34	2.24	3.79	1.32
	RwT	0.00	0.96	0.86	1.00	2.17	0.63	0.00	1.37	1.26	1.48	3.17	1.15
	Pro	0.00	1.10	0.89	1.21	2.64	0.77	0.00	1.64	1.35	1.67	3.40	1.16

Table B.19: Average TTR for multihop (2 nodes and 10 BL timeslots)

		7 channels						14 channels					
		ZERO	LOW	LONG	HIGH	INTER	MIXPR	ZERO	LOW	LONG	HIGH	INTER	MIXPR
EMCA	No	54.91	56.44	75.70	110.90	63.91	66.27	69.62	75.56	110.79	166.00	85.00	87.40
	Norm	54.55	67.20	105.36	223.83	101.94	81.89	71.73	84.83	140.67	292.66	127.03	110.14
	RwoT	54.93	53.17	56.74	108.20	74.15	53.36	71.67	67.69	58.83	88.05	74.46	58.83
	RwT	53.69	50.91	53.45	95.98	70.57	48.47	70.49	65.67	53.92	88.25	74.35	57.21
	Pro	55.26	53.82	55.59	96.78	69.09	55.36	71.26	65.69	60.45	84.51	73.57	60.27
RAND	No	56.30	58.29	77.52	112.36	64.58	67.60	72.33	78.19	112.79	169.11	90.27	94.57
	Norm	56.79	68.22	106.80	226.11	105.30	83.10	73.32	91.10	146.17	310.64	130.71	115.48
	RwoT	56.29	54.23	57.37	110.67	74.81	55.28	72.81	69.69	60.14	94.94	76.12	59.33
	RwT	55.25	53.38	57.11	122.85	73.15	52.66	72.11	66.96	58.21	93.88	76.15	58.48
	Pro	55.96	55.67	58.60	105.98	72.47	62.84	72.48	75.16	63.12	92.17	78.70	69.60
JS	No	80.07	81.59	120.87	179.79	86.85	95.22	92.21	104.29	128.92	201.22	119.84	118.78
	Norm	78.79	93.60	193.22	350.21	172.29	143.06	89.38	111.80	199.53	381.49	197.43	150.16
	RwoT	77.40	85.93	120.35	243.65	140.48	93.26	90.06	115.27	165.91	299.65	156.07	138.84
	RwT	75.70	58.01	64.06	123.10	76.12	60.68	90.32	71.14	63.44	101.20	78.23	75.78
	Pro	75.21	58.32	57.34	103.25	73.44	67.15	90.21	77.62	65.37	91.32	76.01	79.81
MMCA	No	83.06	84.40	95.18	148.09	84.71	101.33	110.65	118.88	133.80	221.16	136.30	134.96
	Norm	83.04	105.36	136.65	254.09	120.32	132.74	114.83	147.72	195.61	368.23	172.50	136.45
	RwoT	83.42	77.48	99.12	151.84	120.74	81.84	113.64	118.46	134.12	127.55	128.15	111.57
	RwT	83.14	66.35	65.99	116.10	81.33	63.38	113.04	77.09	63.43	99.49	83.08	64.19
	Pro	82.15	57.56	60.17	104.37	74.89	75.30	114.70	72.08	63.47	89.72	76.09	71.33
EXJS	No	73.60	82.58	121.80	166.20	103.26	96.45	97.01	108.60	154.83	224.16	120.64	130.82
	Norm	74.50	98.69	183.07	406.20	168.89	179.29	95.37	120.11	236.31	435.75	201.63	179.05
	RwoT	74.94	87.38	106.81	230.84	151.75	120.04	93.17	127.52	164.61	311.61	184.79	141.92
	RwT	74.64	57.45	62.28	121.14	76.63	60.90	94.52	70.04	63.28	106.27	77.35	70.18
	Pro	74.69	60.80	63.42	103.47	77.93	69.88	94.09	76.08	63.98	89.59	76.33	88.48

Table B.20: Average TTR for multihop (10 nodes and 10 BL timeslots)

		7 channels						14 channels					
		ZERO	LOW	LONG	HIGH	INTER	MIXPR	ZERO	LOW	LONG	HIGH	INTER	MIXPR
EMCA	No	66.60	72.72	102.60	152.88	82.16	84.29	91.82	104.66	150.53	232.72	118.22	124.02
	Norm	66.27	86.09	140.83	312.71	144.08	107.36	91.19	116.09	193.54	396.61	174.58	144.91
	RwoT	66.77	67.38	74.52	163.62	101.43	64.64	90.88	87.21	73.62	125.58	99.23	74.38
	RwT	65.24	59.51	69.59	144.38	100.74	58.22	91.67	84.55	69.91	123.10	94.22	69.83
	Pro	65.04	65.11	71.97	140.51	98.07	73.13	91.16	87.65	76.97	119.06	96.25	82.13
RAND	No	67.80	74.06	103.87	154.36	83.77	88.66	93.44	110.62	154.75	236.14	120.38	125.56
	Norm	67.37	87.48	145.63	338.62	148.32	109.24	92.43	119.69	198.88	460.72	186.15	158.81
	RwoT	67.36	68.27	75.57	166.05	103.10	65.47	94.05	88.08	75.40	126.74	100.69	75.28
	RwT	66.41	62.88	75.51	153.40	97.44	62.54	94.11	89.81	73.58	135.74	97.26	72.30
	Pro	67.15	68.69	76.86	145.93	100.86	79.09	94.32	91.72	78.66	128.00	103.31	95.07
JS	No	97.17	104.16	134.08	199.28	113.45	115.86	131.14	132.56	203.49	301.42	149.57	169.38
	Norm	95.38	107.32	226.54	451.79	219.99	160.27	129.96	150.24	253.36	542.11	249.74	193.42
	RwoT	95.95	105.92	150.02	297.77	160.56	142.12	128.03	147.14	234.76	408.14	226.51	183.42
	RwT	94.79	71.73	88.44	197.28	107.98	85.05	125.90	95.53	81.10	145.28	110.56	94.71
	Pro	94.48	74.22	75.84	155.33	102.53	101.65	126.15	99.16	85.50	124.14	102.06	112.63
MMCA	No	93.00	94.86	123.13	179.61	94.40	134.96	137.59	144.11	209.02	290.14	156.31	190.30
	Norm	92.26	121.08	168.07	364.17	205.98	145.67	134.92	149.83	230.85	457.63	253.92	216.27
	RwoT	92.15	80.26	108.19	226.18	137.54	114.87	137.54	138.13	112.69	189.79	157.05	115.32
	RwT	91.31	77.93	90.74	180.34	119.38	89.59	130.32	101.26	85.15	148.24	102.59	97.49
	Pro	91.78	69.86	75.76	151.30	103.79	84.45	135.00	94.04	81.23	130.27	99.04	90.42
EXJS	No	104.48	111.30	152.98	215.56	131.70	126.57	148.89	152.01	249.28	319.24	175.19	182.77
	Norm	102.90	134.97	215.81	406.68	222.18	182.97	145.10	166.95	283.87	549.98	283.33	231.71
	RwoT	104.74	118.31	153.25	266.08	153.77	128.30	144.90	161.59	237.80	424.00	251.85	198.05
	RwT	104.40	70.41	82.19	185.11	108.41	83.11	142.39	96.51	85.14	149.08	108.44	91.55
	Pro	103.72	74.21	79.37	160.28	102.12	109.72	141.05	103.67	87.07	125.67	104.70	140.98

Table B.21: Percentage improvement of multihop EMCA over other rendezvous strategies in terms of ATTR (2 nodes, 10 BL TSs)

		7 channels						14 channels					
		ZERO	LOW	LONG	HIGH	INTER	MIXPR	ZERO	LOW	LONG	HIGH	INTER	MIXPR
RAND	No	2.47	3.17	2.35	1.30	1.04	1.97	3.75	3.36	1.77	1.84	5.84	7.58
	Norm	3.94	1.50	1.35	1.01	3.19	1.46	2.17	6.88	3.76	5.79	2.82	4.62
	RwoT	2.42	1.95	1.10	2.23	0.88	3.47	1.57	2.87	2.18	7.26	2.18	0.84
	RwT	2.82	4.63	6.40	21.88	3.54	7.96	2.25	1.91	7.37	6.00	2.36	2.16
	Pro	1.25	3.32	5.14	8.68	4.66	11.90	1.68	12.60	4.23	8.31	6.52	13.41
JS	No	31.42	30.82	37.37	38.32	26.41	30.40	24.50	27.55	14.06	17.50	29.07	26.42
	Norm	30.77	28.20	45.47	36.09	40.83	42.76	19.75	24.12	29.50	23.29	35.66	26.65
	RwoT	29.03	38.12	52.86	55.59	47.22	42.78	20.42	41.28	64.54	70.62	52.29	57.63
	RwT	29.07	12.24	16.55	22.03	7.29	20.12	21.96	7.69	15.01	12.79	4.95	24.50
	Pro	26.53	7.72	3.05	6.27	5.92	17.56	21.01	15.37	7.53	7.46	3.21	24.48
MMCA	No	33.89	33.13	20.47	25.11	24.55	34.60	37.08	36.44	17.20	24.94	37.64	35.24
	Norm	34.31	36.22	22.90	11.91	15.28	38.31	37.53	42.57	28.09	20.52	26.36	19.28
	RwoT	34.15	31.38	42.76	28.74	38.59	34.80	36.93	42.86	56.14	30.97	41.90	47.27
	RwT	35.42	23.27	19.00	17.33	13.23	23.53	37.65	14.80	15.00	11.30	10.51	10.87
	Pro	32.73	6.50	7.61	7.27	7.74	26.48	37.87	8.87	4.76	5.81	3.31	15.51
EXJS	No	25.40	31.65	37.85	33.27	38.11	31.29	28.23	30.42	28.44	25.95	29.54	33.19
	Norm	26.78	31.91	42.45	44.90	39.64	54.33	24.79	29.37	40.47	32.84	37.00	38.49
	RwoT	26.70	39.15	46.88	53.13	51.14	55.55	23.08	46.92	64.26	71.74	59.71	58.55
	RwT	28.06	11.39	14.17	20.77	7.92	20.42	25.43	6.23	14.79	16.96	3.87	18.48
	Pro	26.01	11.48	12.35	6.47	11.34	20.78	24.26	13.66	5.52	5.67	3.62	31.88

Table B.22: Percentage improvement of multihop EMCA over other rendezvous strategies in terms of ATTR (10 nodes, 10 BL TSs)

		7 channels						14 channels					
		ZERO	LOW	LONG	HIGH	INTER	MIXPR	ZERO	LOW	LONG	HIGH	INTER	MIXPR
RAND	No	1.77	1.81	1.22	0.96	1.92	4.93	1.73	5.39	2.73	1.45	1.79	1.23
	Norm	1.63	1.59	3.30	7.65	2.86	1.72	1.34	3.01	2.69	13.92	6.22	8.75
	RwoT	0.88	1.30	1.39	1.46	1.62	1.27	3.37	0.99	2.36	0.92	1.45	1.20
	RwT	1.77	5.35	7.84	5.88	-3.38	6.91	2.59	5.85	4.99	9.31	3.12	3.42
	Pro	3.14	5.21	6.36	3.71	2.77	7.54	3.35	4.44	2.15	6.98	6.83	13.61
JS	No	31.46	30.18	23.48	23.28	27.58	27.25	29.98	21.05	26.03	22.79	20.96	26.78
	Norm	30.52	19.78	37.83	30.78	34.51	33.01	29.83	22.73	23.61	26.84	30.10	25.08
	RwoT	30.41	36.39	50.33	45.05	36.83	54.52	29.02	40.73	68.64	69.23	56.19	59.45
	RwT	31.18	17.03	21.32	26.81	6.70	31.55	27.19	11.49	13.79	15.27	14.78	26.27
	Pro	31.16	12.27	5.10	9.54	4.35	28.06	27.74	11.61	9.98	4.09	5.69	27.08
MMCA	No	28.39	23.34	16.67	14.88	12.97	37.54	33.27	27.37	27.98	19.79	24.37	34.83
	Norm	28.17	28.90	16.21	14.13	30.05	26.30	32.41	22.52	16.16	13.33	31.25	33.00
	RwoT	27.54	16.05	31.12	27.66	26.25	43.73	33.92	36.86	34.67	33.83	36.82	35.50
	RwT	28.56	23.64	23.31	19.94	15.62	35.02	29.66	16.50	17.90	16.96	8.16	28.37
	Pro	29.13	6.80	5.00	7.13	5.51	13.40	32.47	6.79	5.24	8.61	2.82	9.17
EXJS	No	36.26	34.66	32.93	29.08	37.61	33.41	38.33	31.15	39.61	27.10	32.52	32.14
	Norm	35.60	36.22	34.74	23.11	35.15	41.32	37.15	30.46	31.82	27.89	38.38	37.46
	RwoT	36.25	43.05	51.37	38.51	34.04	49.62	37.28	46.03	69.04	70.38	60.60	62.44
	RwT	37.51	15.48	15.34	22.00	7.08	29.95	35.62	12.39	17.88	17.43	13.11	23.72
	Pro	37.29	12.26	9.32	12.33	3.97	33.35	35.37	15.45	11.60	5.26	8.07	41.74

Table B.23: Average HI for multihop (2 nodes and 10 BL timeslots)

		7 channels						14 channels					
		ZERO	LOW	LONG	HIGH	INTER	MIXPR	ZERO	LOW	LONG	HIGH	INTER	MIXPR
EMCA	No	0.00	0.16	0.19	0.33	0.77	0.26	0.00	0.32	0.32	0.52	0.77	0.34
	Norm	0.00	0.17	0.17	0.19	0.31	0.06	0.00	0.25	0.23	0.53	0.46	0.22
	RwoT	0.00	0.17	0.16	0.15	0.39	0.20	0.00	0.27	0.21	0.28	0.59	0.26
	RwT	0.00	0.17	0.09	0.14	0.41	0.14	0.00	0.34	0.16	0.29	0.74	0.24
	Pro	0.00	0.18	0.15	0.21	0.52	0.11	0.00	0.25	0.29	0.29	0.58	0.19
RAND	No	0.00	0.17	0.14	0.25	0.74	0.32	0.00	0.33	0.35	0.42	0.92	0.33
	Norm	0.00	0.15	0.10	0.17	0.25	0.07	0.00	0.22	0.24	0.30	0.66	0.20
	RwoT	0.00	0.14	0.13	0.24	0.45	0.14	0.00	0.33	0.29	0.43	0.71	0.25
	RwT	0.00	0.11	0.25	0.18	0.42	0.11	0.00	0.18	0.25	0.25	0.69	0.20
	Pro	0.00	0.25	0.23	0.21	0.45	0.08	0.00	0.32	0.20	0.33	0.99	0.22
JS	No	0.00	0.21	0.21	0.53	0.91	0.37	0.00	0.35	0.34	0.54	0.91	0.44
	Norm	0.00	0.22	0.38	0.23	0.45	0.12	0.00	0.38	0.20	0.51	0.91	0.24
	RwoT	0.00	0.27	0.26	0.18	0.41	0.19	0.00	0.23	0.16	0.40	0.69	0.20
	RwT	0.00	0.17	0.13	0.17	0.34	0.18	0.00	0.40	0.23	0.28	0.63	0.17
	Pro	0.00	0.25	0.11	0.20	0.36	0.09	0.00	0.31	0.23	0.41	0.91	0.20
MMCA	No	0.00	0.29	0.17	0.47	0.80	0.39	0.00	0.38	0.29	0.59	1.18	0.54
	Norm	0.00	0.33	0.13	0.21	0.47	0.26	0.00	0.46	0.35	0.48	0.82	0.25
	RwoT	0.00	0.28	0.20	0.18	0.57	0.24	0.00	0.46	0.38	0.33	1.01	0.38
	RwT	0.00	0.23	0.26	0.12	0.34	0.16	0.00	0.36	0.24	0.28	0.73	0.13
	Pro	0.00	0.29	0.19	0.20	0.36	0.16	0.00	0.30	0.33	0.28	0.74	0.21
EXJS	No	0.00	0.33	0.22	0.46	1.00	0.35	0.00	0.42	0.41	0.61	1.34	0.45
	Norm	0.00	0.23	0.22	0.33	0.65	0.17	0.00	0.29	0.26	0.33	0.79	0.24
	RwoT	0.00	0.25	0.16	0.35	0.52	0.16	0.00	0.25	0.25	0.26	0.77	0.15
	RwT	0.00	0.19	0.16	0.15	0.39	0.13	0.00	0.27	0.25	0.24	0.58	0.16
	Pro	0.00	0.18	0.19	0.16	0.55	0.07	0.00	0.29	0.29	0.30	0.72	0.16

Table B.24: Average HI for mulithop (10 nodes and 10 BL timeslots)

		7 channels						14 channels					
		ZERO	LOW	LONG	HIGH	INTER	MIXPR	ZERO	LOW	LONG	HIGH	INTER	MIXPR
EMCA	No	0.00	0.96	0.80	1.48	2.95	1.09	0.00	1.36	1.21	1.96	4.04	1.29
	Norm	0.00	0.82	0.53	0.85	1.72	0.55	0.00	1.10	0.91	1.79	2.74	0.95
	RwoT	0.00	0.62	0.59	1.12	1.56	0.54	0.00	1.25	0.83	1.23	2.97	0.93
	RwT	0.00	0.66	0.63	0.64	1.73	0.50	0.00	1.11	0.76	1.18	3.06	0.79
	Pro	0.00	0.82	0.76	0.99	1.96	0.59	0.00	1.32	0.96	1.48	2.81	0.53
RAND	No	0.00	0.87	1.09	1.44	2.66	1.02	0.00	1.52	1.17	2.29	3.97	1.60
	Norm	0.00	0.59	0.53	1.06	1.37	0.44	0.00	1.04	0.89	1.92	2.58	0.99
	RwoT	0.00	0.93	0.65	0.97	2.01	0.57	0.00	1.37	1.00	1.21	3.31	0.70
	RwT	0.00	0.69	0.69	0.75	2.06	0.45	0.00	1.32	0.88	1.52	3.09	0.84
	Pro	0.00	0.68	0.84	0.91	2.02	0.52	0.00	1.23	1.22	1.56	3.27	0.75
JS	No	0.00	0.82	1.12	1.86	4.05	1.11	0.00	1.78	1.59	2.49	5.20	2.13
	Norm	0.00	0.96	0.97	1.13	2.50	0.71	0.00	1.33	1.09	2.28	3.36	1.12
	RwoT	0.00	0.77	0.82	0.87	1.23	0.61	0.00	1.28	1.16	1.80	3.23	1.17
	RwT	0.00	0.93	0.57	1.06	1.83	0.47	0.00	1.22	0.88	1.39	3.04	0.78
	Pro	0.00	1.07	0.75	0.99	2.13	2.10	0.00	1.24	1.20	1.47	3.42	0.70
MMCA	No	0.00	0.99	0.76	1.08	2.45	0.99	0.00	1.77	1.70	2.79	5.64	2.09
	Norm	0.00	1.02	0.78	1.16	2.35	0.71	0.00	1.39	1.12	1.97	4.04	1.41
	RwoT	0.00	0.77	0.73	1.21	2.38	0.98	0.00	1.93	1.36	1.91	3.89	1.29
	RwT	0.00	0.95	0.75	0.81	2.04	0.72	0.00	1.63	1.10	1.38	3.47	0.97
	Pro	0.00	0.85	0.63	1.28	2.24	0.61	0.00	1.59	1.00	1.58	3.27	0.73
EXJS	No	0.00	1.13	1.27	2.01	4.62	1.58	0.00	1.97	1.78	3.13	6.35	2.14
	Norm	0.00	0.91	0.98	1.11	2.36	0.88	0.00	1.43	1.03	1.89	3.02	1.27
	RwoT	0.00	0.92	0.86	1.16	2.01	0.72	0.00	1.27	1.19	1.53	2.92	1.07
	RwT	0.00	0.68	0.80	1.07	1.87	0.45	0.00	1.51	0.91	1.40	2.99	0.81
	Pro	0.00	1.15	0.73	1.08	2.08	0.49	0.00	1.64	1.37	1.60	3.49	0.82

References

- [1] The International Disaster Database, EM-DAT, USAID Program, Report on Disasters in 2017. [Available at] <http://www.emdat.be/>
- [2] Communications Status Report for Areas Impacted by Tropical Storm Harvey, Federal Communications Commission, August 2017. [Available at] https://apps.fcc.gov/edocs_public/attachmatch/DOC-346369A1.pdf
- [3] Gianmarco Baldini, Stan Karanasios, David Allen and Fabrizio Vergari. Survey of Wireless Communication Technologies for Public Safety. *IEEE Communications Surveys and Tutorials*. volume 16, number 2, pages 619-641, 2013, .
- [4] Joseph Mitola III and Gerald Q. Maguire. Cognitive Radio: Making Software Radio More Personal. *IEEE Personal Communications*, volume 6, number 4, 1999.
- [5] Saim Ghafoor, Paul D. Sutton, Cormac J. Sreenan and Kenneth N. Brown. Cognitive radio for disaster response networks: survey, potential, and challenges. *IEEE Wireless Communications*, volume 21, number 5, pages 70-80, 2014.
- [6] IEEE 802.22.2: Installation and Deployment of Cognitive Radio Systems, 2012. [Available at] <http://standards.ieee.org/getieee802/download/802.22.2-2012.pdf>
- [7] SAFECOM, US communications program of the Department of Homeland Security. Public Safety Statements of Requirements for Communications and Interoperability v I and II. [Available at] http://www.npstc.org/documents/SRSorR_V11_030606.pdf
- [8] Chris Lewis and Steve Pickavance. Implementing Quality of Service. In *Selecting MPLS VPN Services*, ed. 1st, Pearson Education, pages 139-185, 2008.

- [9] Kelly T. Morrison. Rapidly Recovering from the Catastrophic Loss of a Major Telecommunications Office. *IEEE Communication Magazine*. volume 49, number 1, pages 28-35, 2011.
- [10] Ian F. Akyildiz, Won-yeol Lee, Mehmet C. Vuran and Shantidev Mohanty. A Survey on Spectrum Management in Cognitive Radio Networks. *IEEE Communication Magazine*, volume 46, number 4, pages 40-48, 2008.
- [11] William Webb. Weightless: The Technology to Finally Realise the M2M Vision. In *International Journal of Interdisciplinary Telecommunications and Networking (IJITN)*, volume 4, no. 2, pages 30-37, 2012.
- [12] 3GPP; Technical Specification Group Services and System Aspects; Proximity-based services (ProSe); Stage 2, 3GPP TS 23.303, Release 13 (2016-03).
- [13] Przemyslaw Pawelczak, Keith Nolan, Linda Doyle, Ser W. Oh and Danijela Cabric. Cognitive Radio: Ten Years of Experimentation and Development. *IEEE Communication Magazine*, volume 49, number 3, pages 90-100, 2011.
- [14] Peter Steenkiste, Douglas Sicker, Gary Minden and Dipankar Raychaudhuri. Future Directions in Cognitive Radio Network Research. In *NSF Workshop Report*, 2009.
- [15] Mubashir H. Rehmani, Aline C. Viana, Hicham Khalife and Serge Fedida. A Cognitive Radio based Internet Access Framework for Disaster Response Network Deployment. In *Proceedings of 4th International Workshop on Cognitive Radio and Advanced Spectrum Management (CogART)*, pages 1-5, 2011.
- [16] Evren Onem, Salim Eryigit, Tuna Tugcu and Ali Akurgal. QoS-enabled Spectrum-aware Routing for Disaster Relief and Tactical Operations over Cognitive Radio Ad-hoc Networks. In *IEEE Military Communications Conference (MILCOM)*. pages 1109-1115, 2013.
- [17] Chin L. Wang, Han. W. Chen and Yuan. X. Cheng. Sensing-Delay Trade-off for Cognitive Radio Networks with QoS Considerations. *IEEE 78th Vehicular Technology Conference (VTC)*, pages 1-5, 2013.
- [18] Paul D. Sutton, Keith E. Nolan, and Linda E. Doyle. Cyclostationary Signatures in Practical Cognitive Radio Applications. *IEEE Journal on Selected Areas in Communications (JSAC)*, volume 26, number 1, pages 13-24, 2008.

- [19] Arash Azarfar, Jean F. Frogon and Brunilde Sanso. Improving the Reliability of Wireless Networks using Cognitive Radios. *IEEE Communications Surveys and Tutorials*, volume 14, number 2, pages 338-354, 2012.
- [20] H. Birkan Yilmaz, Tuna Tugcu, Fatih Alagoz and Suzan Bayhan. Radio Environment Map as Enabler for Practical Cognitive Radio Networks. *IEEE Communications Magazine*, volume 51, number 12, pages 162-169, 2013.
- [21] Ian F. Akyildiz, Won Y. Lee and Kaushik R. Chowdhury. CRAHN: Cognitive Radio Ad-hoc Networks. *Journal of Ad-Hoc Networks*, volume 7, number 5, pages 810-836, 2009.
- [22] Shamik Sengupta and K. P. Subbalakshmi. Open Research Issues in Multihop CRNs. *IEEE Communication Magazine*, volume 51, number 4, pages 168-176, 2013.
- [23] Kaushik R. Chowdhry and Ian F. Akyildiz. Cognitive Wireless Mesh Networks with Dynamic Spectrum Access. *IEEE Journal on Selected Areas in Communications (JSAC)*, volume 26, number 1, pages 168-181, 2008.
- [24] Keith E. Nolan, Paul D. Sutton, Linda E. Doyle, T. W. Rondeau, B. Le and C. W. Bostian. Demonstration and Analyses of Collaboration, Coexistence, and Interoperability of Cognitive Radio Platforms. In *4th IEEE International Conference on Consumer Communications and Networking Conference (CCNC)*, pages 1149-1153, January 2007.
- [25] Tore Ulversoy. Software Defined Radio: Challenges and Opportunities. *IEEE Communication Surveys and Tutorials*, volume 12, number 4, pages 531-550, 2010.
- [26] Steve Alpern, The Rendezvous Search Problem. *2nd Ed. SIAM Journal on Control and Optimization*, volume 33, number 3, pages 673-683, 1995.
- [27] Steve Alpern, Rendezvous Search: A Personal Perspective. *Operations Research*, volume 50, number 5, pages 772-795, 2002.
- [28] Athar. A. Khan, Mubashir H. Rehmani, Yasir Saleem, Neighbour discovery in traditional wireless networks and cognitive radio networks: Basics, taxonomy, challenges and future research directions. *Journal of Network and Computer Applications*, volume 52, pages 173-190, 2015.
- [29] Hai Liu, Zhiyong Lin, Xiaowen Chu and Yiu W. Leung, Taxonomy and challenges of rendezvous algorithms in cognitive radio networks. In *International*

- Conference on Computing, Networking and Communications (ICNC)*, Maui, HI, pages 645-649, 2012.
- [30] Aohan Li, Guangjie Han, Joel J. P. C. Rodrigues and Sammy Chan, Channel Hopping Protocols for Dynamic Spectrum Management in 5G Technology. *IEEE Wireless Communications*, volume 24, number 5, pages 102-109, 2017.
- [31] Brandon. F. Lo, A survey of common control channel design in cognitive radio networks. *Physical Communication*, volume 4, number 1, Pages 26-39, 2011.
- [32] Zaw Htike, Choong S. Hong and Sungwon Lee. The Life Cycle of the Rendezvous Problem of Cognitive Radio Ad Hoc Networks. *Journal of Computing Science and Engineering*, volume 7, number 2, pages 81-88, 2013.
- [33] Vladimir Brik, Eric Rozner, Suman Banerjee and Paramvir Bahl. DSAP: a protocol for coordinated spectrum access. In *Proceedings of IEEE International Symposium on Dynamic Spectrum Access Networks (DySPAN)*, pages 611-614, 2005.
- [34] Milind M. Buddhikot, Paul Kolodzy, Scott Miller, Kevin Ryan and Jason Evans. DIMSUMnet: new directions in wireless networking using coordinated dynamic spectrum. In *Proceedings of IEEE International Symposium on a World of Wireless, Mobile and Multimedia Networks (WoWMoM)*, pages 78-85, 2005.
- [35] Yogesh R. Kondareddy, Prathima Agrawal and Krishna Sivalingam. Cognitive Radio Network setup without a Common Control Channel. In *IEEE Military Communications Conference (MILCOM)*, San Diego, CA, pages 1-6, 2008.
- [36] Juncheng Jia, Qian Zhang and Xuemin S. Shen. HC-MAC: a hardware-constrained cognitive MAC for efficient spectrum management. *IEEE journal on selected areas in communications*, volume 26, number 1, pages 106-117, 2008.
- [37] Liangping Ma, Xiaofeng Han and Chien C. Shen. Dynamic open spectrum sharing for wireless ad hoc networks. In *Proceedings of IEEE International Symposium on Dynamic Spectrum Access Networks (DySPAN)*, pages 203-213, Nov. 2005.
- [38] Jun Zhao, Haitao Zheng and Guang H. Yang. Distributed Coordination in Dynamic Spectrum Allocation Networks. In *Proceedings of IEEE International Symposium on Dynamic Spectrum Access Networks (DySPAN)*, pages 259-268, 2005.

- [39] Loukas Lazos, Sisi Liu and Marwan Krunz. Spectrum Opportunity-based Control Channel Assignment in Cognitive Radio Networks. In *IEEE International Conference on Sensing, Communication and Networking (SECON)*, pages 1-9, 2009.
- [40] Nick. C. Theis, Ryan W. Thomas, and Luiz A. DaSilva. Rendezvous for Cognitive Radios. *IEEE Transactions on Mobile Computing*, volume 10, number 2, pages 216-227, 2011.
- [41] Lu Yu, Hai Liu, Yiu W. Leung, Xiaowen Chu and Zhiyong Lin. Channel-hopping based on available channel set for rendezvous of cognitive radios. In *IEEE International Conference on Communications (ICC)*, Sydney, NSW, pages 1573-1579, 2014.
- [42] Parsan K. Sahoo, and Debasish Sahoo. Sequence-Based Channel Hopping Algorithms for Dynamic Spectrum Sharing in Cognitive Radio Networks. *IEEE Journal of Selected Areas in Communications*, volume 34, number 11, pages 2814–28, 2016.
- [43] Chih M. Chao, Chien Y. Hsu, and Yun T. Ling. Efficient Asynchronous Channel Hopping Design for Cognitive Radio Networks. *IEEE Transactions on Vehicular Technology*, volume 65, number 9, pages 6888–6900, 2016,.
- [44] Guey Y. Chang, Wen H. Teng, Hao Y and Jang P. Sheu. Chen. Novel Channel-Hopping Schemes for Cognitive Radio Networks. *IEEE Transactions on Mobile Computing*, volume 13, number 2, pages 407–421, 2014.
- [45] Xingyiya Liu and Jiang Xie. SUBSET, A joint design of channel selection and channel hopping for fast blind rendezvous in cognitive radio ad hoc networks. In *12th Annual IEEE International Conference on Sensing, Communication, and Networking (SECON)*, Seattle, WA, pages 426-434, 2015.
- [46] Cheng S. Chang, Cheng Y. Chen, Duan S. Lee and Wanjiun Liao. Efficient Encoding of User IDs for Nearly Optimal Expected Time-To-Rendezvous in Heterogeneous Cognitive Radio Networks. *IEEE/ACM Transactions on Networking*, volume 25, number 6, pages 3323-3337, 2017.
- [47] Quan Liu, Xudong Wang, Biao Han, Xiaodong Wang and Xingming Zhou. Access Delay of Cognitive Radio Networks Based on Asynchronous Channel-Hopping Rendezvous and CSMA/CA MAC. In *IEEE Transactions on Vehicular Technology*, volume 64, number 3, pages 1105-1119, 2015.

- [48] Hai Liu, Zhiyong Lin, Xiaowen Chu and Yiu W. Leung, Jump-Stay Rendezvous Algorithm for Cognitive Radio Networks. *IEEE Transactions on Parallel and Distributed Systems*, volume 23, number 10, pages 1867-1881, 2012.
- [49] Zhiyong Lin, Hai Liu, Xiaowen Chu and Yiu W. Leung, Enhanced Jump-Stay Rendezvous Algorithm for Cognitive Radio Networks. *IEEE Communications Letters*, volume 17, number 9, pages 1742-1745, 2013.
- [50] Rajib. Paul and Young J. Choi, Adaptive Rendezvous for Heterogeneous Channel Environments in Cognitive Radio Networks. *IEEE Transactions on Wireless Communications*, volume 15, number 11, pages 7753-7765, 2016.
- [51] Jiaxun Li, Haitao Zhao, Jibo Wei, Dongtang Ma and Li Zhou, Sender-Jump Receiver-Wait: A Simple Blind Rendezvous Algorithm for Distributed Cognitive Radio Networks. *IEEE Transactions on Mobile Computing*, volume 17, number 1, pages 183-196, 2018.
- [52] I. H. Chuang, Hsiao Y. Wu and Yau H. Kuo, A Fast Blind Rendezvous Method by Alternate Hop-and-Wait Channel Hopping in Cognitive Radio Networks. *IEEE Transactions on Mobile Computing*, volume 13, number 10, pages 2171-2184, 2014.
- [53] Zifan Li and David J. Thunte, Extensions and improvements of jump-stay rendezvous algorithms for Cognitive Radios. In *International Conference on Selected Topics in Mobile and Wireless Networking (MoWNeT)*, Avignon, pages 1-8, 2017.
- [54] Young H. Oh and David J. Thunte, Jamming and advanced modular-based blind rendezvous algorithms for Cognitive Radio Networks. In *IEEE 17th International Symposium on A World of Wireless, Mobile and Multimedia Networks (WoWMoM)*, Coimbra, pages 1-10, 2016.
- [55] Saber Salehkaleybar and Mohammad R. Pakravan, A periodic jump-based rendezvous algorithm in cognitive radio networks. *Computer Communications*, volume 79, pages 66-77, 2016.
- [56] Chih M. Chao and Hsiang Y. Fu, Supporting Fast Rendezvous Guarantee by Randomized Quorum and Latin Square for Cognitive Radio Networks. *IEEE Transactions on Vehicular Technology*, volume 65, number 10, pages 8388-8399, 2016.

- [57] Jang P. Sheu, Chih W. Su and Guey Y. Chang, Asynchronous Quorum-Based Blind Rendezvous Schemes for Cognitive Radio Networks. *IEEE Transactions on Communications*, volume 64, number 3, pages 918-930, 2016.
- [58] Chih M. Chao, Hsiang Y. Fu and Li R. Zhang, A Fast Rendezvous-Guarantee Channel Hopping Protocol for Cognitive Radio Networks. *IEEE Transactions on Vehicular Technology*, volume 64, number 12, pages 5804-5816, 2015.
- [59] Yifan Zhang, Gexin Yu, Qun Li, Haodong Wang, Xiaojun Zhu and Baosheng Wang, Channel-Hopping-Based Communication Rendezvous in Cognitive Radio Networks. *IEEE/ACM Transactions on Networking*, volume 22, number 3, pages 889-902, 2014.
- [60] Luiz A. DaSilva and Igor Guerreiro. Sequence-Based Rendezvous for Dynamic Spectrum Access. In *IEEE Symposium on New Frontiers in Dynamic Spectrum Access Networks (DySPAN)*, Chicago, IL, pages 1-7, 2008.
- [61] Mohammad A. Hossain, Nurul I. Sarkar, A distributed multichannel MAC protocol for rendezvous establishment in cognitive radio ad hoc networks. *Ad Hoc Networks*, volume 70, pages 44-60, 2018.
- [62] Cheng S. Chang, Wanjiun Liao and Tsung Y. Wu, Tight Lower Bounds for Channel Hopping Schemes in Cognitive Radio Networks. *IEEE/ACM Transactions on Networking*, volume 24, number 4, pages 2343-2356, 2016.
- [63] Wei C. Chen, Guu C. Yang, Min K. Chang and Wing C. Kwong, Construction and Analysis of Shift-Invariant, Asynchronous-Symmetric Channel-Hopping Sequences for Cognitive Radio Networks. *IEEE Transactions on Communications*, volume 65, number 4, pages 1494-1506, 2017.
- [64] Jen F. Huang, Guey Y. Chang and Jian X. Huang, Anti-Jamming Rendezvous Scheme for Cognitive Radio Networks. *IEEE Transactions on Mobile Computing*, volume 16, number 3, pages 648-661, 2017.
- [65] Guey Y. Chang, Szu Y. Wang and Yuen X. Liu, A Jamming-Resistant Channel Hopping Scheme for Cognitive Radio Networks. *IEEE Transactions on Wireless Communications*, volume 16, number 10, pages 6712-6725, 2017.
- [66] Guey Y. Chang, Jen F. Huang and Yao S. Wang, Matrix-Based Channel Hopping Algorithms for Cognitive Radio Networks. *IEEE Transactions on Wireless Communications*, volume 14, number 5, pages 2755-2768, 2015.

- [67] Bo Yang, Wei Liang, Meng Zheng and Ying C. Liang, Fully Distributed Channel-Hopping Algorithms for Rendezvous Setup in Cognitive Multiradio Networks. *IEEE Transactions on Vehicular Technology*, volume 65, number 10, pages 8629-8643, 2016.
- [68] Juncheng Jia and Qian Zhang, Rendezvous Protocols Based on Message Passing in Cognitive Radio Networks. *IEEE Transactions on Wireless Communications*, volume 12, number 11, pages 5594-5606, 2013.
- [69] Claudia Cormio and Kaushik R. Chowdhury, Common control channel design for cognitive radio wireless ad hoc networks using adaptive frequency hopping. *Ad Hoc Networks*, volume 8, pages 430-438, 2010.
- [70] Yanyan Zeng, K. Alex Mills, Shreyas Gokhale, Neeraj Mittal, S. Venkatesan and R. Chandrasekaran, Robust Neighbour discovery in multi-hop multi-channel heterogeneous wireless networks. *Journal of Parallel and Distributed Computing*, volume 92, pages 15-34, 2016.
- [71] Xingya Liu and Jiang Xie, A practical self-adaptive rendezvous protocol in cognitive radio ad hoc networks. In *IEEE International Conference on Computer Communications (INFOCOM)*, Toronto, ON, pages 2085-2093, 2014.
- [72] Apurva N. Mody, Matthew. J. Sherman, Ralph Martinez, Ranga Reddy and Thomas Kiernan, Survey of IEEE standards supporting cognitive radio and dynamic spectrum access. *IEEE Military Communications Conference (MILCOM)*, San Diego, CA, pages 1-7, 2008.
- [73] Timothy X. Brown, Policy-based radios for spectrum sharing. In *IST-Africa Conference and Exhibition*, Nairobi, pages 1-9, 2013.
- [74] Xiaoshuang Xing, Tao Jing, Wei Cheng, Yan Huo and Xiuzhen Cheng, Spectrum prediction in cognitive radio networks. *IEEE Wireless Communications*, volume 20, number 2, pages 90-96, 2013.
- [75] Fayaz Akhtar, Mubashir H. Rehmani, Martin Reisslein, White space: Definitional perspectives and their role in exploiting spectrum opportunities. *Telecommunications Policy*, volume 40, number 4, pages 319-331, 2016.
- [76] Yunfei Chen and Hee S. Oh, A Survey of Measurement-Based Spectrum Occupancy Modeling for Cognitive Radios. *IEEE Communications Surveys and Tutorials*, volume 18, number 1, pages 848-859, 2016.

- [77] M. Hoyhtya et al., Spectrum Occupancy Measurements: A Survey and Use of Interference Maps. *IEEE Communications Surveys and Tutorials*, volume 18, number 4, pages 2386-2414, 2016.
- [78] Miguel L. Benitez, Fernando Casadevall, Spectrum usage models for the analysis, design and simulation of cognitive radio networks. In *Cognitive Radio and its Applications for Next Generation Cellular and Wireless Networks, Lecture Notes in Electrical Engineering*, Springer, 2012.
- [79] Yasir Saleem, Mubashir H. Rehmani, Primary radio user activity models for cognitive radio networks- A survey. *Journal of Network and Computer Applications*, volume 43, pages 1-16, 2014.
- [80] Mubashir H. Rehmani, Aline C. Viana, Hicham Khalife, Serge Fdida, SURF A distributed channel selection strategy for data dissemination in multi-hop cognitive radio networks. *Elsevier Computer Communications*, volume 36, number 10-11, pages 1172-1185, 2013.
- [81] Suzan Bayhan, Fatih Alagoz, A Markovian approach for best-fit channel selection in cognitive radio networks. *Ad Hoc Networks*, volume 12, pages 165-177, 2014.
- [82] Yang Li, Yu N. Dong, Hui Zhang, Hai T. Zhao, Hai X. Shi and Xin. X. Zhao, Spectrum Usage Prediction Based on High-order Markov Model for Cognitive Radio Networks. In *10th IEEE International Conference on Computer and Information Technology (CIT)*, Bradford, pages 2784-2788, 2010.
- [83] Alexander W. Min, Kang G. Shin, Exploiting multi-channel diversity in spectrum-agile network. In *IEEE International Conference on Computer Communications (INFOCOM)*, 2008.
- [84] Hyoil Kim, Kang G. Shin, Efficient discovery of spectrum opportunities with mac-layer sensing in cognitive radio networks. *IEEE Transactions on Mobile Computing*, volume 7, number 5, pages 533-545, 2008.
- [85] Hyoil Kim, Kang G. Shin, Fast discovery of spectrum opportunities in cognitive radio networks. In *IEEE International Symposium on Dynamic Spectrum Access Networks (DySPAN)*, 2008.
- [86] Mubashir H. Rehmani, Aline C. Viana, Hicham Khalife, Serge Fdida, Activity pattern impact of primary radio nodes on channel selection strategies. In *Proceedings of the 4th international conference on cognitive radio and advanced spectrum management*, ACM, page 36, 2011.

- [87] Yasir Al-Mathehaji, Said Boussakta, Martin Johnston and Harith Fakhrey, CRBP: A broadcast protocol for Cognitive Radio ad hoc networks. In *IEEE International Conference on Communications (ICC)*, London, pages 7540-7545, 2015.
- [88] Yasir Saleem, Kok-Lim A. Yau, Hafizal Mohamad, Nordin Ramli, Mubashir H. Rehmani, SMART: A spectrum aware cluster-based routing scheme for distributed cognitive radio networks. *Elsevier Computer Networks*, volume 91, pages 196-224, 2015.
- [89] Zheng Wang, Yong H. Chew and Chau Yuen, On discretizing the exponential on-off primary radio activities in simulations. In *IEEE 22nd International Symposium on Personal, Indoor and Mobile Radio Communications*, Toronto, ON, pages 556-560, 2011.
- [90] Shanshan Wang, Junshan Zhang and Lang Tong, A Characterization of Delay Performance of Cognitive Medium Access. *IEEE Transactions on Wireless Communications*, volume 11, no. 2, pages 800-809, 2012.
- [91] Lei Jiao, Enbin Song, Vicent Pla and Frank Y. Li, Capacity Upper Bound of Channel Assembling in Cognitive Radio Networks With Quasistationary Primary User Activities. In *IEEE Transactions on Vehicular Technology*, volume 62, number 4, pages 1849-1855, 2013.
- [92] Lei Yang, Lili Cao, Haitao Zheng, Proactive channel access in dynamic spectrum networks. *Elsevier Physical Communications Journal*, volume 1, pages 103-111, 2008.
- [93] Bozidar Vujicic, Nikola Cackov, Svetlana Vujicic, Ljiljana Trajkovic, Modeling and characterization of traffic in public safety wireless networks. In *Proceedings of SPECTS*, 2005.
- [94] Abdelnaser Adas, Traffic models in broadband networks. *IEEE Communications Magazine*, volume 35, number 7, pages 82-89, 1997.
- [95] Stefan Geirhofer, Lang Tong, Brian M. Sadler, Dynamic spectrum access in wlan channels, empirical model and its stochastic analysis. In *ACM TAPAS*, 2006.
- [96] Cognitive Radio Cognitive Network Simulator. [Available at] http://faculty.uml.edu/Tricia_Chigan/Research/CRCN_Simulator.htm

- [97] Emergency Telecommunication Cluster (ETC), ICT Humanitarian Emergency Platform, World Food Program (WFP), 2015. [Available at] <http://ictemergency.wfp.org/>
- [98] Network Disaster Recovery, AT&T, 2015. [Available at] <http://www.corp.att.com/ndr/>
- [99] Fionan Mc Grath, Disaster Response Report. Business As Usual: How AT&T deals with Natural Disasters, 2014. [Available at] <http://www.gsma.com/mobilefordevelopment/new-disaster-response-report-business-as-usual-how-att-deals-with-natural-disasters>
- [100] Orawan Tipmongkolsilp, Said Zaghoul and Admela Jukan, The evolution of Cellular Backhaul Technologies: Current Issues and Future Trends. *IEEE communication Surveys and Tutotials*, volume 13, number 1, pages 97-113, 2011.
- [101] Mona Jaber, Muhammad A. Imran, Rahim Tafazolli and Anvar Tukmanov, 5G Backhaul Challenges and Emerging Research Directions: A Survey. *IEEE Access*, volume 4, pages 1743-1766, 2016.
- [102] Kurtis Heimral and Eric Brewer. The Village Base Station. In *4th ACM Workshop on Networked Systems for Developing Regions (NSDR)*, 2010.
- [103] Veljko Pejovic, David L. Jhonson, Mariya Zheleva, Elizabeth M. Belding and Albert Lysko. VillageLink: Wide-area Wireless Coverage. In *International Conference on Communication Systems and Networks (COMSNETS)*, pages 6-10, 2014.
- [104] Jacqueline Mpala and Gertjan V. Stam. Open BTS, a GSM experiment in rural Zambia. In *International conference on e-Infrastructure and e-Services for Developing Countries*. Springer, volume 119, pages 65-73, 2013.
- [105] Kurtis Heimerl, Shaddi Hasan, Kashif Ali, Eric Brewer and Tapan Parikh. Local, Sustainable, Small-Scale Cellular Networks. In *International Conference on Information and Communication Technologies and Development (ICTD)*, pages 2-12, 2013.
- [106] Mariya Zheleva, Arghyadip Paul, David L. Johnson, and Elizabeth M. Belding. Kwiizya-Local cellular network services in remote areas. In *International Conference on Mobile system, applications, and services (ACM MobiSys)*, pages 417-430, 2013.

- [107] Abhinav Anand, Veljko Pejovic, Elizabeth M. Belding, David L. Johnson. Village Cell: Cost Effective Cellular Connectivity in Rural Areas. In *International Conference on Information and Comm Tech. and Development (ACM ICTD)*, pages 180-189, 2012.
- [108] Gráinne Hanley, Seán Murphy and Liam Murphy. Performance of VoIP over IEEE 802.11G DSSS-OFDM Mode with IEEE 802.11E QOS Support. In *In E-business and Telecommunication Networks*, volume 3, pages 201-214, 2007.
- [109] Dragos S. Niculescu, Samrat Ganguly, Kyungtae Kim and Rauf Izmailov. Performance of VoIP in a 802.11 Wireless Mesh Network. In *Proceedings of INFOCOM*, pages 1-11, 2006.
- [110] Nor K. Ibrahim, Mohammad Razif A. Razak, Abdul H. Ali, Wan M. S. M. Yatim. The Performance of VoIP over IEEE 802.11. In *European Modelling Symposium (EMS)*, pages 607-610, 2013.
- [111] Michael Iedema. Getting started with OpenBTS. *O'Reilly*, 2014.
- [112] Universal Software Radio Peripheral, N210. [Available at] <https://www.ettus.com/product>
- [113] OpenBTS Application Suite, User Manual, Release 4.0. [Available at] <http://openbts.org/site/wp-content/uploads/2014/07/OpenBTS-4.0-Manual.pdf>
- [114] Tokunbo Ogunfunmi and Madihally Narasimha, Principles of Speech Coding. In (*1st ed.*). *CRC Press, Inc.*, Boca Raton, FL, USA, 2010.
- [115] J. Rosenberg, H. Schulzrinne, G. Camarillo, A. Johnston, J. Peterson, R. Sparks, M. Handley and E. Schooler. RFC3261 - SIP: Session initiation protocol. *Technical report*, IETF, 2002. [Available at] <https://tools.ietf.org/pdf/rfc3261.pdf>
- [116] H. Schulzrinne, S. Casner, R. Frederick and V. Jacobson. RFC 3550: RTP: A Transport Protocol for Real-Time Applications. *Technical report*, IETF, 2003. [Available at] <https://tools.ietf.org/html/rfc3550>
- [117] ITU-T G.107. The E-Model, a computational model for use in transmission planning, 2011.
- [118] ITU-T SG12-D106-E. Estimates of I_e and B_{pl} parameters for a range of CODEC types, 2003.

- [119] Tim Szigeti and Christina Hattingh. QoS Design Overview. End-to-End QoS Network Design: Quality of Service in LANs, WANs, and VPNs. In *Cisco Press*, pages 33-38, 2004.
- [120] Miao Ma and Danny H. K. Tsang, Impact of Channel Heterogeneity on Spectrum Sharing in Cognitive Radio Networks. In *IEEE International Conference on Communications*, Beijing, pages 2377-2382, 2008.
- [121] Sylwia Romaszko, A Rendezvous Protocol with the Heterogeneous Spectrum Availability Analysis for Cognitive Radio Ad Hoc Networks. *Journal of Electrical and Computer Engineering*, 18 pages, article 715816, 2013.
- [122] Qihui Wu, Guoru Ding, Jinlong Wang and Yu D. Yao, Spatial-Temporal Opportunity Detection for Spectrum-Heterogeneous Cognitive Radio Networks: Two-Dimensional Sensing. *IEEE Transactions on Wireless Communications*, volume 12, number 2, pages 516-526, 2013.
- [123] Carl R. Stevenson, Gerald Chouinard, Zhongding Lei, Wendong Hu, Stephen J. Shellhammer and Winston Caldwell. IEEE 802.22: The first cognitive radio wireless regional area network standard. *IEEE Communications Magazine*, volume 47, number 1, pages 130-138, 2009.
- [124] Andrew Robertson, Lan Tran, Joseph Molnar and Er-Hsein F. Fu, Experimental comparison of blind rendezvous algorithms for tactical networks. In *IEEE International Symposium on a World of Wireless, Mobile and Multimedia Networks (WoWMoM)*, San Francisco, CA, pages 1-6, 2012.
- [125] ITU-R [M.1652-1]: Dynamic frequency selection in wireless access systems including radio local area networks for the purpose of protecting the radio determination service in the 5 GHz band, 2011. [Available at] https://www.itu.int/dms_pubrec/itu-r/rec/m/R-REC-M.1652-1-201105-I!!PDF-E.pdf