

**UCC Library and UCC researchers have made this item openly available.
Please [let us know](#) how this has helped you. Thanks!**

Title	Piezo-force and vibration analysis of ZnO nanowire arrays for sensor application
Author(s)	Christian, B.; Volk, J.; Lukàcs, I. E.; Sautieff, E.; Sturm, C.; Graillot, A.; Dauksevicus, Rolanas; O'Reilly, Eoin P.; Ambacher, O.; Lebedev, V.
Publication date	2017-01-04
Original citation	Christian, B., Volk, J., Lukàcs, I. E., Sautieff, E., Sturm, C., Graillot, A., Dauksevicus, R., O'Reilly, E., Ambacher, O. and Lebedev, V. (2016) 'Piezo-force and Vibration Analysis of ZnO Nanowire Arrays for Sensor Application', Procedia Engineering, 168, pp. 1192-1195. doi:10.1016/j.proeng.2016.11.406
Type of publication	Conference item
Link to publisher's version	http://dx.doi.org/10.1016/j.proeng.2016.11.406 Access to the full text of the published version may require a subscription.
Rights	© 2016, the Authors. Published by Elsevier Ltd. This is an open access article under the CC BY-NC-ND license (http://creativecommons.org/licenses/by-nc-nd/4.0/) http://creativecommons.org/licenses/by-nc-nd/4.0/
Item downloaded from	http://hdl.handle.net/10468/3617

Downloaded on 2021-01-27T11:18:40Z

30th Eurosensors Conference, EUROSENSORS 2016

Piezo-force and vibration analysis of ZnO nanowire arrays for sensor application

B. Christian^{a*}, J. Volk^b, I. E. Lukàcs^b, E. Sautieff^c, C. Sturm^d, A. Graillet^e, R. Dauksevičius^f, E. O'Reilly^g, O. Ambacher^{a,h}, V. Lebedev^a

^aFraunhofer IAF, Freiburg, Germany; ^bMTA EK MFA, Budapest, Hungary; ^cCEA Leti, Grenoble, France; ^dUniversität Leipzig, Leipzig, Germany; ^eSpecific Polymers, Montpellier, France; ^fKaunas University of Technology, Kaunas, Lithuania; ^gTyndall National Institute, Cork, Ireland; ^hUniversity of Freiburg, Freiburg, Germany

Abstract

To estimate the potential of ZnO nanostructures for force sensing applications, arrays of single nanowires and arrays of nanowire bundles have been fabricated by wet chemical growth method. The piezoelectrical and electrical properties of the single nanowires have been investigated by atomic force microscopy based techniques. The piezoelectric constant $d_{33} = 15$ pm/V has been determined from vibration analyses. The electrical response in the range up to 400 fA upon applying force between 40 nN and 1 μ N has been recorded. The nanowire bundles were studied by electro-mechanical macro probing technique within the force range 1 - 10 mN, where a reproducible response in pA range has been measured.

© 2016 Published by Elsevier Ltd. This is an open access article under the CC BY-NC-ND license (<http://creativecommons.org/licenses/by-nc-nd/4.0/>).

Peer-review under responsibility of the organizing committee of the 30th Eurosensors Conference

Keywords: ZnO; Nanowire Arrays; Piezoelectric sensors; Fingerprint; AFM

1. Introduction

Due to the rising safety concerns in mobile devices, comprehensive biometric technologies such as fingerprint sensing attract much interest from the hardware and software producers. Generally, fingerprints have three levels of details, which can be used for user identification: i) simple uncomplete overview for level one, ii) exact ridge-valley sequence for level two and iii) exact position of every pore for level three [1]. Due to the lack of compact sensors,

* Corresponding author. Tel.: +49-761-5159-263; fax: +49-761-5159-71263.
E-mail address: bjoern.christian@iaf.fraunhofer.de

the today's fingerprint resolution standard is limited to the level one detail monitoring (500 DPI). To image the level two features, at least 1000 DPI resolution is required, while 5000 DPI is essential for the level three topographies. To exceed the limitations of state of the art sensors in the project PiezoMAT ZnO nanowires (NW) are used as sensor structure. Combining the possibility to be grown on pre-patterned silicon substrates using wet chemical growth method (WCG) [2] with their piezoelectric properties when grown in wurtzite crystal structure, addressable high density ZnO NW arrays are a technology with the potential to be the base for next generation fingerprint applications. In the present work, electrical and piezo-electrical properties of single ZnO NWs as well as arrays of addressable NW bundles encapsulated in a stiff polymer matrix are reported and discussed. It is demonstrated that an increase in nanostructure size and load force leads to higher electrical force-response signals.

2. Fabrication and experimental conditions

2.1. Sample fabrication

For atomic force microscopy (AFM) based vibration analyses and force-response measurements with load forces up to 1 μN , ordered arrays of single standing ZnO NWs have been grown by WCG (Fig. 1a) [2]. First, an Al-doped ZnO (AZO) seed layer has been deposited on sapphire substrate by pulsed laser deposition (PLD). Second, a polymethylmethacrylat (PMMA) mask layer was deposited and patterned to define growth windows for the selective NW growth.

For force-response measurements in an electrical macro setup with forces in the range of 1 – 10 mN, first, pre-patterned silicon-based chips have been micro-fabricated to realize the addressable matrices of ZnO NW pixels. The chips were equipped with a ring bottom electrode defining NW growth spot (pixel), metal tracks and a protective Si_xN_y layer. On those chips a PLD-AZO seed layer has been deposited and structured for the NW growth on top of the electrodes. The overview SEM image of direct addressable 10×10 array of ZnO NW pixels is shown in Fig. 1b. As opposite to stand-alone NWs on sapphire, every pixel, in this case, consists of many vertically aligned NWs (a bundle pixel structure). To stabilize the NW structures, an active chip area is encapsulated with a $\sim 1 \mu\text{m}$ thick polymer formulation containing 65wt% of hexanediol-diacrylate and 35wt% of PPG-diacrylate [3]. The polymer was then partly etched in oxygen plasma in order to liberate the NW tips for a top electrical contact. The top electrode is realized by coating the chip active area by conductive silver/polymer hybrid layer.

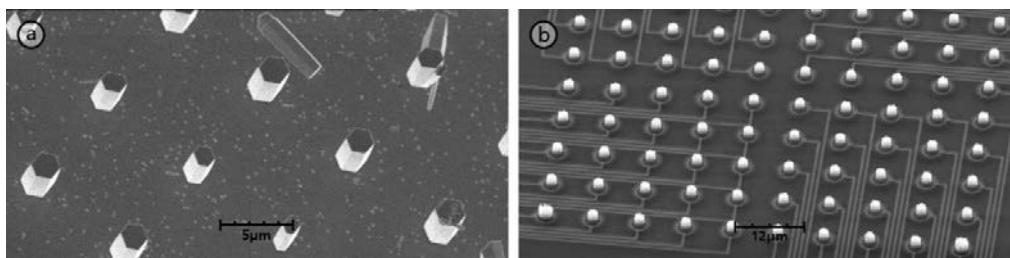

Fig. 1: a - array of single crystalline ZnO nanorods grown by hydrothermal method;
b - array of singly bottom contacted ZnO nanorod bunches before polymer encapsulation

2.2. Experimental details

In Fig. 2, the schematic views for all three measurement configurations are displayed, designed for AFM based force-response (a) and d_{33} vibration (b) analyses along with macro-probing setup for force-response measurements of multi-NW pixels (c). The AFM based measurements were carried out using JPK NanoWizard III equipment. For force-modulation probing a conductive AFM tip has been connected to a SP-300 potentiostat. After localizing the nanostructures by tapping mode AFM, the tip was moved towards the NW surface along the z-axis until a certain set-point at the four-quadrant photo diode (QPD) is reached. The value of the set point is proportional to the applied force with sensitivity and force constant of the cantilever as proportionality factors:

$$F = V_{QPD} \cdot S_{CL} \cdot k_{CL}, \quad (1)$$

where F is the applied force, V_{OPD} the voltage at the photo diode, S_{CL} the sensitivity of the cantilever and k_{CL} the force constant of the cantilever.

The NW vibrational analyses were carried out to determine the piezoelectric charge coefficient (d_{33}) of ZnO nanostructures. Single NW was piezo-electrically excited in the 33 direction by providing electrical signal from AC generator $V_{AC} = 5 V_{PP}$ at 10 kHz to its top and bottom contacts connected via AFM tip and conducting seed layer, respectively. A Signal Recovery lock-in amplifier was employed to record a modulated signal from the QPD using the generator signal as a reference. The d_{33} value has been calculated using the following equation:

$$d_{33} = \frac{V_{OPD} \cdot S}{V_{AC}} \cdot C, \tag{2}$$

where S_{CL} is determined from the cantilever calibration routine [4], and the calibration factor $C = 9.37$ is a value accounting for the probing geometry being derived from the measurement of reference sample: 2H-AlN micro-pillars with known $d_{33} = 5.5 \text{ pC/N}$ value as determined by laser Doppler vibrometry.

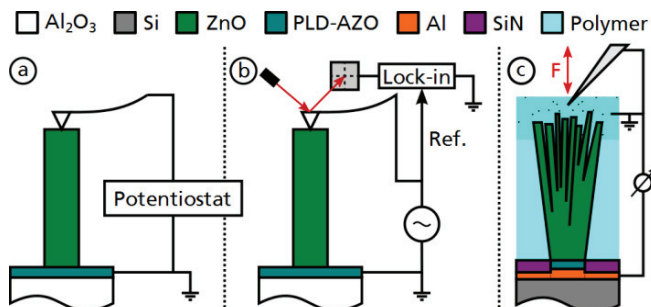

Fig. 2: a - AFM setup for force-response measurements; b - AFM setup for vibration analysis; c - makro setup for force-response measurements under high load

In the macro-probing setup every single pixel is electrically addressed via an individual ring-bottom-electrode. The top conductive polymer is used as ground electrode for all pixels. The tungsten probe with rounded tip is used to apply force to the active area of the sensor. A rough xyz-positioning of the mechanical probe is realized by stepper motors, while a nano-positioning unit enables highly reproducible sub-nm-scale needle movement in z-axis. The needle tip location on z-axis defines the applied force, which has been estimated separately using a force sensor.

3. Experimental results and discussion

3.1. Vibration analysis

For the cantilever used in the experiments, $S_{CL} = 34.2 \text{ nm/V}$ was derived by calibration. The typical AC bias amplitude at 10 kHz detected by the lock-in amplifier upon applying an excitation voltage of $V_{AC} = 5 V_{PP}$ onto and well-oriented ZnO NWs was in the range of $V_{LI} = 220 \pm 30 \mu\text{V}$. Using Eq. 2, the effective piezoelectric charge coefficient of ZnO NWs was determined to be $d_{33} = 15 \pm 2 \text{ pC/N}$. For comparison, the V_{LI} values measured on not vertically aligned NWs were below $185 \mu\text{V}$ resulting in $d_{33} < 12 \text{ pC/N}$.

3.2. Force-response measurements

The time-domain force-response measurements carried out using the AFM set-up demonstrates reproducibly an electrical signal of $\sim 400 \text{ fA}$ (Fig. 3a) for a relative AFM tip movement of $\sim 150 \text{ nm}$. This corresponds to the maximal compressive force magnitude of $\sim 1 \mu\text{N}$. Here, the signal recorded upon pressing the NW remains constant in time, while the response received after breaking the mechanical contact with NW varies. Scan over different force set-points does not cause a variation in the signal magnitude indicating that the signal is not force dependent, and therefore not truly piezo-induced. Direct calculation of the net generated charge by integrating the current curve peaks delivers a value of $Q_{pz}^s \sim 0.5 \text{ pC}$, which exceeds an expected piezo-response by order of magnitudes. One

possible explanation of the excess charge generation is a dominating contribution of spontaneous polarization phenomena, which is characteristic for hexagonal crystals such as ZnO, AlN, etc. More details on the observed phenomena can be found in Ref. [5].

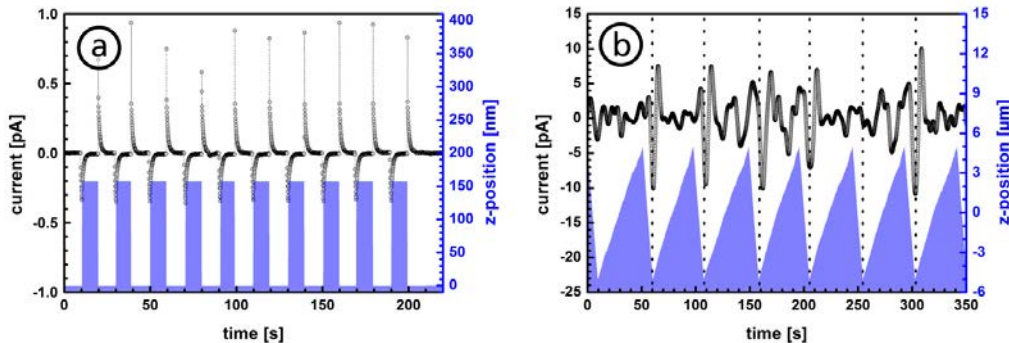

Fig. 3: a - force response measurement results of single nanorods obtained by AFM; b - force response measurement results of nanorod bundles obtained by electrical macro measurement setup; here, z-position (force) is given in arbitrary units.

The NW bundle pixels measured by means of macro-probe techniques also demonstrate a peak electrical response of ~ 10 pA, which is highly reproducible in time (Fig. 3b). In these experiments, the magnitude of the applied force did not exceed 10 mN. It is important to note that all tested pixels deliver comparable electrical signals, which can be explained by a multi NW structure of the bundle. In this case, the recorded signal is a collective response of many NWs and cannot differ significantly from pixel to pixel. From integration of the current peaks, an averaged generated charge of $Q_{pz} \sim 27$ pC is obtained. Comparing this value to the results obtained on single NWs ($Q_{pz}^s \sim 0.5$ pC), one can conclude that two factors determined the improved response for the bundle pixels: i) significantly increased force magnitude, and ii) a fact that multiple NWs contribute to the charge generation simultaneously.

4. Conclusion

In this work, ordered arrays consisting of single and bundled ZnO NW pixels have been fabricated by wet chemical growth method. The piezoelectric constant $d_{33} = 15$ pm/V for ZnO NW has been determined from vibration analyses. The electrical response of NWs upon applying a periodical mechanical load in time domain has been recorded and analyzed with the aim to estimate the potential of ZnO NW for high resolution finger print sensors. Comparing the results obtained on single and multi-NW pixels, one can conclude that two factors determined the improved response for the latter configuration: i) higher applied force magnitude, and ii) a collective response of multiple NWs contributing to the charge generation simultaneously.

5. Acknowledgements

This work was funded by the European Commission as part of the Project PiezoMAT in the FP7 framework program. The authors would like to thank all project partners for the cooperation.

References

- [1] D. Braggins, Fingerprint sensing and analysis, *Sens. Rev.*, vol. 21, no. 4, pp. 272–277, 1901.
- [2] J. Volk and R. Erdélyi, Morphology and crystallinity control of wet chemically grown ZnO nanorods, *Turkish J. Phys.*, vol. 38, no. 3, pp. 391–398, 2014.
- [3] A. Bouvet-Marchand et al., UV-crosslinked polymeric materials for encapsulation of ZnO nanowires in piezoelectric fingerprint sensors, EuroSensors 2016, unpublished.
- [4] J. L. Hutter and J. Bechhoefer, Calibration of atomic-force microscope tips, *Rev. Sci. Instrum.*, vol. 64, no. 7, pp. 1868–1873, 1993.
- [5] M. Seifkar, E. P. O'Reilly, B. P. Christian, V. Lebedev, J. Volk, R. Erdélyi, I. E. Lukacs, R. Dauksevicius, and R. Gaidys, Enhanced pressure response in ZnO nanorods due to spontaneous polarization charge, *IEEE-NANO 2015 - 15th Int. Conf. Nanotechnol.*, no. 611019, pp. 1465–1468, 2016.