

**UCC Library and UCC researchers have made this item openly available.  
Please [let us know](#) how this has helped you. Thanks!**

<b>Title</b>	Carrier-induced refractive index in quantum dot structures due to transitions from discrete quantum dot levels to continuum states
<b>Author(s)</b>	Uskov, Alexander V.; O'Reilly, Eoin P.; McPeake, Dermot; Ledentsov, Nikolai N.; Bimberg, D.; Huyet, Guillaume
<b>Publication date</b>	2004
<b>Original citation</b>	Uskov, A. V., O'Reilly, E. P., McPeake, D., Ledentsov, N. N., Bimberg, D. and Huyet, G. (2004) 'Carrier-induced refractive index in quantum dot structures due to transitions from discrete quantum dot levels to continuum states', Applied Physics Letters, 84(2), pp. 272-274. doi: 10.1063/1.1639933
<b>Type of publication</b>	Article (peer-reviewed)
<b>Link to publisher's version</b>	<a href="http://aip.scitation.org/doi/abs/10.1063/1.1639933">http://aip.scitation.org/doi/abs/10.1063/1.1639933</a> <a href="http://dx.doi.org/10.1063/1.1639933">http://dx.doi.org/10.1063/1.1639933</a> Access to the full text of the published version may require a subscription.
<b>Rights</b>	© 2004 American Institute of Physics. This article may be downloaded for personal use only. Any other use requires prior permission of the author and AIP Publishing. The following article appeared in Uskov, A. V., O'Reilly, E. P., McPeake, D., Ledentsov, N. N., Bimberg, D. and Huyet, G. (2004) 'Carrier-induced refractive index in quantum dot structures due to transitions from discrete quantum dot levels to continuum states', Applied Physics Letters, 84(2), pp. 272-274 and may be found at <a href="http://aip.scitation.org/doi/abs/10.1063/1.1639933">http://aip.scitation.org/doi/abs/10.1063/1.1639933</a>
<b>Item downloaded from</b>	<a href="http://hdl.handle.net/10468/4401">http://hdl.handle.net/10468/4401</a>

Downloaded on 2022-05-16T16:10:52Z

## Carrier-induced refractive index in quantum dot structures due to transitions from discrete quantum dot levels to continuum states

A. V. Uskov, E. P. O'Reilly, and D. McPeakeN. N. Ledentsov and D. BimbergG. Huyet

Citation: *Appl. Phys. Lett.* **84**, 272 (2004); doi: 10.1063/1.1639933

View online: <http://dx.doi.org/10.1063/1.1639933>

View Table of Contents: <http://aip.scitation.org/toc/apl/84/2>

Published by the [American Institute of Physics](#)

---

---



COMPUTING

ENGINEERING

SCIENCE

*CiSE* magazine is  
an innovative blend.

**computing**  
- SCIENCE - ENGINEERING  
EXPLORING OUR  
SOLAR SYSTEM

# Carrier-induced refractive index in quantum dot structures due to transitions from discrete quantum dot levels to continuum states

A. V. Uskov,<sup>a)</sup> E. P. O'Reilly, and D. McPeake  
 NMRC, University College, Lee Maltings, Prospect Row, Cork, Ireland

N. N. Ledentsov<sup>b)</sup> and D. Bimberg  
 Institut für Festkörperphysik TU Berlin, Harderbergstr. 36, D-10623, Germany

G. Huyet  
 Physics Department, National University of Ireland, University College, Cork, Ireland

(Received 1 October 2003; accepted 17 November 2003)

The carrier-induced refractive index in quantum dot (QD) structures due to optical transitions from QD levels to continuum states is considered. It is shown that, for large photon energies, the refractive index change is given asymptotically by the Drude formula. Calculations of the linewidth enhancement factor,  $\alpha$ , show that  $\alpha \sim 1$  due to this contribution to the total refractive index. Furthermore, for highly localized QD states, the absorption coefficient at the photon energies  $\sim 0.8\text{--}1.0$  eV due to these transitions can be on the order of  $10^3$  m<sup>-1</sup>. © 2004 American Institute of Physics. [DOI: 10.1063/1.1639933]

Carrier-induced refractive index changes can strongly influence characteristics of semiconductor laser and amplifiers, such as spectral linewidth, wavelength chirping, mode competition, and beam filamentation.<sup>1–5</sup> In bulk and quantum well (QW) devices, the index change  $\eta$  includes an anomalous dispersion component  $\eta_{\text{res}}$  due to *interband* resonant transitions and a “free carrier” component  $\eta_{\text{free}}$ , originating from *intra*band transitions [see Fig. 1(a)]:

$$\eta = \eta(\omega, n) = \eta_{\text{res}}(\omega, n) + \eta_{\text{free}}(\omega, n) \approx C(\omega) \cdot n, \quad (1)$$

where  $\omega$  is the probe frequency and  $n$  the carrier density. The dependence of the refractive index on the carrier density is often characterized by the linewidth enhancement ( $\alpha$ -) factor

$$\alpha = -2 \frac{\omega}{c} \frac{\partial \eta / \partial n}{\partial g / \partial n} = -2 \frac{\omega}{c} \frac{C}{g_n}, \quad (2)$$

where  $g_n = \partial g / \partial n$  is the differential gain, and  $C = \partial \eta / \partial n$  is the differential refractive index. In bulk and QW semiconductors, this free carrier component has been studied experimentally,<sup>6</sup> and is well described by Drude's model for the refractive index of a free carrier plasma.<sup>6</sup>

The carrier-induced refractive index in quantum dot (QD) structures and corresponding  $\alpha$  factor are presently under intensive experimental study.<sup>7–10</sup> Measured values are usually associated only with the resonant refractive index calculated by considering “interband” transitions between the electron and hole QD levels [dashed line in Fig. 1(b)].<sup>11–13</sup> As shown in Ref. 11, these interband transitions in QDs can lead to the  $\alpha$  factor being zero or even negative, in contrast to the positive  $\alpha$  values in bulk and QW devices. However, a wide range of experiments has reported positive  $\alpha$  factors  $\sim 1\text{--}2$ <sup>8,12</sup> in QD devices. In Ref. 12, these results

have been attributed to the effect of inhomogeneous broadening on the refractive index. In this letter, we consider a different mechanism, which can also lead to positive  $\alpha$  factor  $\sim 1$ .

We present model calculations of the refractive index  $\eta_{\text{dc}}$  due the transitions between a discrete QD level and a continuum of states above the QD [Fig. 1(b)]. This index can be considered as an analog of the free carrier component  $\eta_{\text{free}}$  in bulk or QW devices. We give a general formula for  $\eta_{\text{dc}}$ , and evaluate it using model carrier wave functions. At large photon energies, this formula tends asymptotically to Drude's formula. At low photon energies, we find significant deviations from the Drude model, even resulting in positive index changes. From the Kramers–Kronig dispersion relations we can relate  $\eta_{\text{dc}}$  to the absorption coefficient of photons due to these “ionizing” transitions.

We consider the interaction of QD carriers with an electromagnetic wave propagating in the waveguide of a QD laser or amplifier. The vector potential of the field is  $\mathbf{A}(t) = (-i\mathbf{E}_0/\omega) \cdot \exp(-i\omega t) + \text{c.c.}$ , and the electric field,  $\mathbf{E}_0$ , is polarized along the  $z$  axis. The carrier-photon interaction Hamiltonian is  $\hat{V} = -e\mathbf{A}(t)\hat{\mathbf{p}}/m$ , where  $\hat{\mathbf{p}} = -i\hbar\nabla$ , with  $e$  as the charge and  $m$  as the mass of the carrier. Using the density

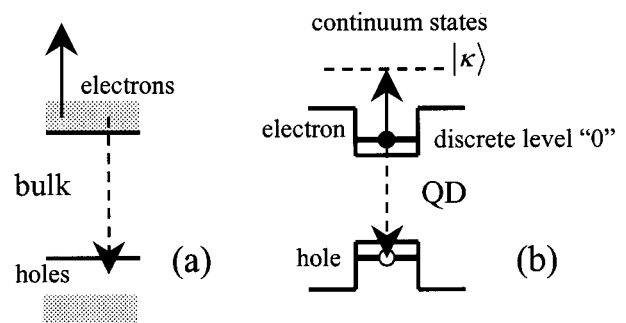

FIG. 1. Band structure of bulk (a) and QD (b) semiconductor with interband (dash) and intraband transitions (solid). Intraband transitions are shown only for electrons.

<sup>a)</sup>Also at: P. N. Lebedev Physical Institute, Leninsky pr. 53, 117924 Moscow, Russia; electronic mail: alexusk@sci.lebedev.ru

<sup>b)</sup>Also at: A. F. Ioffe Physical-Technical Institute, Politeknicheskaya 26, 194021 St. Petersburg, Russia.

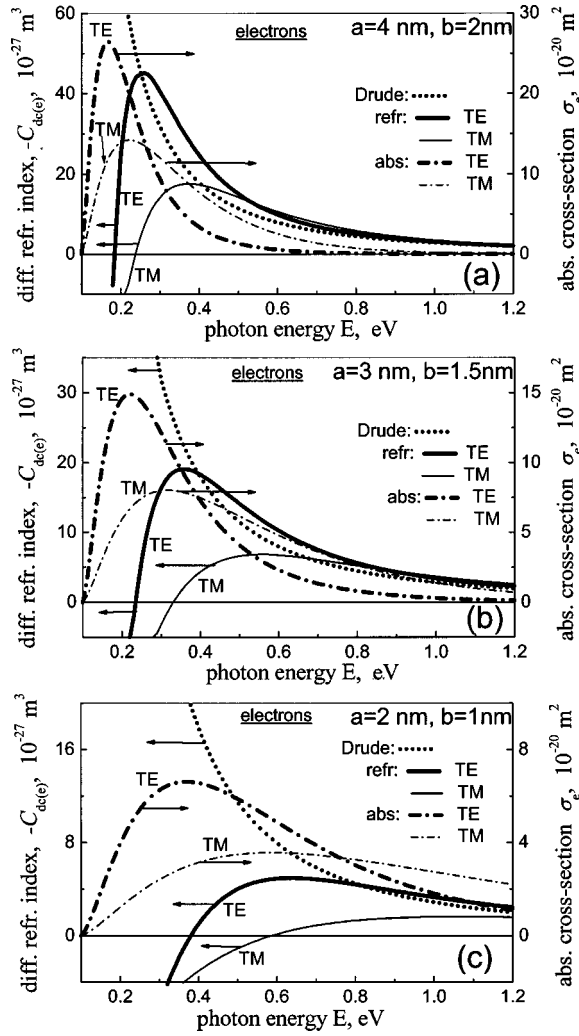

FIG. 2. Spectra of the differential refractive index  $C_{dc(e)}$  (solid curves) and the absorption cross-section  $\sigma_e$  (dot-dash curves) due electron transitions from QD level to continuum for TE polarization (thick curves) and TM polarization (thin curves). The refractive index from Drude's model is shown by the dotted curve.

matrix approach, the induced polarization due to transitions between a bound state  $|0\rangle$  in a QD and a state  $|\kappa\rangle$  in the continuum [see Fig. 2(b)] is given by

$$\mathbf{p}_{0\kappa} = e^2 \rho_0 / (m \omega^2) \cdot \mathbf{r}_{0\kappa} (\mathbf{E}_0 \cdot \nabla_{\kappa 0}) \cdot 2D_{\kappa 0}(\omega) \cdot e^{-i\omega t}, \quad (3)$$

where

$$D_{\kappa 0}(\omega) = \omega/2 [(\omega - \omega_{\kappa 0} + i\gamma_2)^{-1} + (\omega + \omega_{\kappa 0} + i\gamma_2)^{-1}]; \quad (4)$$

$\omega_{\kappa 0} = (E_{\kappa} - E_0)/\hbar$  is the transition frequency;  $E_{\kappa}$  and  $E_0$  are the energies of the states  $|\kappa\rangle$  and  $|0\rangle$ , respectively;  $\gamma_2 = 1/T_2$ , where  $T_2$  is the dephasing time for the transition; and  $\rho_0$  is the population of the QD level  $|0\rangle$ . In the derivation of Eq. (3) we neglect the population of the state  $|\kappa\rangle$  in comparison with  $\rho_0$  [we assume the energy difference  $(E_{\kappa} - E_0)$  is much larger than the thermal energy  $k_B T$  in the structure]. In Eq. (3),  $\mathbf{r}_{0\kappa} = \langle 0|\mathbf{r}|\kappa\rangle$  and  $\nabla_{\kappa 0} = \langle \kappa|\nabla|0\rangle$ . The induced polarization per unit volume is given by

$$\mathbf{P} = \mathbf{P}_0 e^{-i\omega t} = 2N_D^{(3D)} \cdot \sum_{\kappa} \mathbf{p}_{0\kappa}, \quad (5)$$

where  $N_D^{(3D)}$  is the average three-dimensional (3D) QD density in the waveguide. If the QD laser has  $l$  QD layers with sheet density  $N_D$ , we have  $N_D^{(3D)} = lN_D/t_w$  where  $t_w$  is the effective optical thickness of the waveguide. The factor of 2 in Eq. (5) is due to the spin degeneracy of the ground QD level  $|0\rangle$ . Using the relation  $P_0 = \epsilon_0 \chi E_0$  between the polarization  $P_0$  along the  $z$  axis and the electric field amplitude  $E_0$ , we have for the susceptibility  $\chi_{dc}$  along the  $z$  axis due to the discrete-continuum transitions

$$\chi_{dc} = -e^2 n / (\epsilon_0 m \omega^2) \cdot S, \quad (6)$$

where  $n = \rho_0 \cdot 2N_D^{(3D)}$  is the carrier density in state  $|0\rangle$  in the QDs. The factor  $S$  is given by

$$S = S(\omega) = 2 \sum_{\kappa} z_{\kappa 0} (\partial/\partial z)_{0\kappa} D_{\kappa 0}(\omega). \quad (7)$$

The corresponding refractive index  $\eta_{dc}$  is expressed through the real part of the susceptibility

$$\eta_{dc} = \frac{\text{Re}[\chi_{dc}]}{2\eta_{bg}} = \eta_{\text{Drude}} S_{\text{Re}} = C_{\text{Drude}} n S_{\text{Re}} = C_{dc} \cdot n, \quad (8)$$

where  $\eta_{bg}$  is the background refractive index,  $S_{\text{Re}}$  is the real part of the factor  $S$ , and  $\eta_{\text{Drude}} = -e^2 n / (2\eta_{bg} \epsilon_0 m \omega^2) = C_{\text{Drude}} n$  is the refractive index given by Drude model of a free carrier plasma.<sup>6</sup> Later we use Eqs. (6)–(8) to calculate the differential refractive index  $C_{dc} = C_{\text{Drude}} \cdot S_{\text{Re}}$ , and compare it with the differential refractive index  $C_{\text{Drude}} = -e^2 / (2\eta_{bg} \epsilon_0 m \omega^2)$  predicted by Drude's formula.

From Eqs. (6)–(7), the absorption coefficient is  $\beta = \beta(\omega) = \text{Im}[\chi_{dc}] \omega / (c \eta_{bg}) = \sigma_{dc} \cdot n$  with the absorption cross section

$$\sigma_{dc} = \frac{e^2}{c \eta_{bg} \epsilon_0 m} \cdot \sum_{\kappa} z_{\kappa 0} (\partial/\partial z)_{0\kappa} \frac{\gamma_2}{(\omega - \omega_{\kappa 0})^2 + \gamma_2^2}. \quad (9)$$

Later we calculate the cross section in the limit  $\gamma_2 \rightarrow 0$ .

In the numerical calculations, we make the following approximations. We take into account *only* the states  $|\kappa\rangle$  in a 3D continuum in the sum in Eq. (7), i.e., we neglect the two-dimensional wetting layer states. The 3D states  $|\kappa\rangle$  are approximated by plane waves:  $|\kappa\rangle \rightarrow |\mathbf{k}\rangle = \Omega^{-1/2} \exp(i\mathbf{k}\mathbf{r})$ , where  $\mathbf{k}$  is the 3D wave vector,  $\Omega$  is the normalization volume; and  $E_{\kappa} = \hbar^2 k^2 / 2m$ . Finally, the wave function of the ground QD state is approximated as  $|0\rangle = \pi^{-3/2} a^{-2} b^{-1} \cdot \exp[-(x'^2 + y'^2)/2a^2 - z'^2/2b^2]$ ;<sup>14</sup> the axis  $z'$  is along the growth direction, and the  $x'$  and  $y'$  axes lie in the plane of the QD layers. Later, we assume  $a = 2b$ . We consider two different polarizations of the electric field  $\mathbf{E}$ : TM polarization, when the  $z$  axis of the electric field polarization coincides with the growth direction  $z'$ , and TE polarization, when the  $z$  axis is in the plane of QD layers.

Using the one-band model described here, we have calculated the differential index  $C_{dc(e)}$  due to *electron* transitions (the electron mass is  $m_e = 0.067 \cdot m_0$ ,  $m_0$  is the free electron mass) and the differential index  $C_{dc(h)}$  due to hole transitions (the hole mass is  $m_h = 0.34 \cdot m_0$ ). This one-band model should be a good approximation for the electrons, but is likely to underestimate the hole contribution,  $C_{dc(h)}$ , because it ignores intervalence band absorption, which is generally a significant absorption pathway below 0.8 eV in interband lasers.<sup>15</sup>

The solid curves in Fig. 2 represent the differential refractive index  $C_{dc(e)}$  as a function of the photon energy  $E = \hbar\omega$ . The thick and thin solid lines correspond to the TE and TM polarizations, respectively, and the dotted curve is the Drude differential index,  $C_{\text{Drude}(e)} = -e^2/(2\eta_{\text{bg}}\epsilon_0 m_e \omega^2)$ . As photon energy  $E$  increases, and the probe frequency  $\omega$  becomes much larger than the characteristic oscillation frequency  $\omega_0 \sim \pi^2 \hbar / 2mR_{\text{eff}}^2$  of the QD carriers [ $R_{\text{eff}} = (a^2 b)^{1/3}$  is the effective “radius” of the wave function], the calculated refractive index approaches the value given by Drude’s formula. For QDs with  $b = 1.5, 2$  nm,  $C_{dc(e)}$  is already well approximated by Drude’s formula already at photon energies  $\sim 0.8\text{--}1.0$  eV. At low photon energies ( $\omega \sim \omega_0$ ), the coefficient  $C_{dc(e)}$  deviates from Drude’s formula, and can be even positive, resulting in a negative  $\alpha$  factor [see Eq. (2)]. For QDs with tightly confined carriers ( $b = 1$  nm), deviation from Drude’s formula is clearly observed for  $E \sim 0.8\text{--}1.0$  eV. This asymptotic behavior at large photon energies  $E$  corresponds to neglecting  $\omega_{\kappa 0}$  and  $\gamma_2$  in comparison with  $\omega$  in Eq. (4), so that  $D_{\alpha 0}(\omega) \approx 1$  and  $S_{\text{Re}} = 2\sum_{\alpha} z_{\alpha 0}(\partial/\partial z)_{0\alpha}$ . Since the plane waves  $|\mathbf{k}\rangle$  form a complete set, we have the identity  $S_{\text{Re}} = 2\sum_{k} z_{k0}(\partial/\partial z)_{0k} = 1$ , the oscillator strength sum rule of Thomas–Reich–Kuhn.

The differential refractive index  $C_{dc(h)}$  due hole transitions has a similar behavior to  $C_{dc(e)}$  in the one-band model we are using, albeit with values of  $C_{dc(h)}$  are smaller than  $C_{dc(e)}$ , and approach Drude’s formula at lower frequencies, since the hole mass is larger than the electron mass. The electron and hole contributions are added to each other in the refractive index  $\eta_{dc}$ , so that if populations of electron and hole QD levels are identical, the refractive index  $\eta_{dc} = [C_{dc(e)} + C_{dc(h)}] \cdot n = C_{dc} \cdot n$ . Our one-band calculations give for the total differential index  $C_{dc} \sim -(5-7) \times 10^{-27} \text{ m}^3$  for photon energies  $\sim 0.8\text{--}1$  eV. For comparison, the total differential index (interband transitions plus “plasma effect”) in bulk structures is  $-2 \times 10^{-26} \text{ m}^3$ .<sup>5</sup> We expect that a more accurate multiband model, including intervalence band absorption, may significantly increase  $C_{dc(h)}$  (and  $C_{dc}$ ) both in the QDs studied here, and also in QW and bulk structures. Further calculations are now in progress to test this hypothesis. Using the value of  $C_{dc}$ , calculated earlier, and assuming that the differential gain  $g_n \sim 1 \times 10^{-19} \text{ m}^2$ ,<sup>16</sup> we can estimate from Eq. (2) the contribution  $\alpha_{dc}$  from the discrete-continuum transitions into the  $\alpha$  parameter as  $\alpha_{dc} \sim 1\text{--}2$ . Thus, in experimentally observed values of  $\alpha \sim 2$ , the contribution  $\alpha_{dc}$  can be a substantial part.

Dash-dot curves in Fig. 2 show the cross-section  $\sigma_{dc(e)}$  due to electron transitions. For TE polarization (thick curves), the cross-section  $\sigma_{dc(e)}$  is larger than for TM (thin ones), because for TE polarization the characteristic dipole

moment of carriers in the dot is given by the size  $2a$ , which is assumed to be larger than the size  $2b$ , the dipole moment for TM polarization. The maximum of  $\sigma_{dc(e)}$  takes place at  $\omega \sim \omega_0$ , and shifts to low photon energies for larger QDs. In Figs. 2(b) and 2(c), the cross section is  $\sim 10^{-20} \text{ m}^2$  at  $E \sim 0.8\text{--}1.0$  eV. Assuming the carrier density  $n \sim 10^{23} \text{ m}^{-2}$ , we obtain an estimate for the absorption coefficient of  $\beta \sim 10^3 \text{ m}^{-1}$  which can be substantial for QD lasers. For larger QD ( $a > 5 \text{ nm}, b > 2.5 \text{ nm}$ ), the absorption at  $E \sim 0.8\text{--}1$  eV becomes negligible ( $< 100 \text{ m}^{-1}$ ).

In conclusion, we have shown that optical transitions from QD levels to continuum states leads to carrier-induced refractive index changes, and can result in  $\alpha$  factors  $\sim 1$ . At high photon energies, the refractive index is given approximately by Drude’s formula, while for tightly confined carriers, the corresponding absorption coefficient due to the ionization processes can be  $\sim 10^3 \text{ m}^{-1}$ .

The work was supported by Science Foundation Ireland, RFBR (No. 01-02-17330), INTAS (No. 2001-0571), the Russian Federal Program “Integration” (No. A0155), the EU IST project “DOTCOM,” and the Irish HEA under the PRTL program.

- <sup>1</sup>G. P. Agrawal and N. K. Dutta, *Long-Wavelength Semiconductor Lasers* (Van Nostrand Reinhold, New York, 1986).
- <sup>2</sup>A. P. Bogatov, P. G. Eliseev, and B. N. Sverdlov, *IEEE J. Quantum Electron.* **11**, 510 (1975).
- <sup>3</sup>Ch. Ribbat, R. L. Sellin, I. Kaiander, F. Hopfer, N. N. Ledentsov, D. Bimberg, A. R. Kovsh, V. M. Ustinov, A. E. Zhukov, and M. V. Maximov, *Appl. Phys. Lett.* **82**, 952 (2003).
- <sup>4</sup>P. M. Smowton, E. J. Pearce, H. C. Schneider, W. W. Chow, and M. Hopkinson, *Appl. Phys. Lett.* **81**, 3251 (2002).
- <sup>5</sup>R. J. Manning, A. D. Ellis, A. J. Poustie, and K. L. Blow, *J. Opt. Soc. Am. B* **14**, 3204 (1997).
- <sup>6</sup>C. H. Henry, R. A. Logan, and K. A. Bertness, *J. Appl. Phys.* **52**, 4457 (1981); S. Murata, A. Tomita, and A. Suzuki, *IEEE Photonics Technol. Lett.* **5**, 16 (1993).
- <sup>7</sup>T. C. Newell, D. J. Bossert, A. Stintz, B. Fuchs, K. J. Malloy, and L. F. Lester, *IEEE Photonics Technol. Lett.* **11**, 1527 (1999).
- <sup>8</sup>H. Saito, K. Nishi, A. Kamei, and S. Sigou, *IEEE Photonics Technol. Lett.* **12**, 1298 (2000).
- <sup>9</sup>A. A. Ukhanov, A. Stintz, P. G. Eliseev, and K. J. Malloy, *CLEO’2003*, Baltimore, June 2003, paper CThI2.
- <sup>10</sup>S. Schneider, P. Borri, W. Langbein, U. Woggon, R. L. Sellin, D. Ouyang, and D. Bimberg, *CLEO’2003*, Baltimore, June 2003, paper CThI4.
- <sup>11</sup>M. Willatzen, T. Tanaka, and Y. Arakawa, *IEEE J. Quantum Electron.* **30**, 640 (1994).
- <sup>12</sup>H. C. Schneider, W. W. Chow, and S. W. Koch, *Phys. Rev. B* **66**, 041310 (2002).
- <sup>13</sup>J. Oksanen and J. Tulkki, *J. Appl. Phys.* **94**, 1981 (2003).
- <sup>14</sup>R. Ferreira and G. Bastard, *Appl. Phys. Lett.* **74**, 2818 (1999).
- <sup>15</sup>A. D. Andreev, E. P. O’Reilly, A. R. Adams, and T. Ashley, *Appl. Phys. Lett.* **78**, 2640 (2001).
- <sup>16</sup>N. Hatori, M. Sugawara, K. Mukai, Y. Nakata, and H. Ishikawa, *Appl. Phys. Lett.* **77**, 773 (2000).