

**UCC Library and UCC researchers have made this item openly available.
Please [let us know](#) how this has helped you. Thanks!**

Title	Advanced data acquisition for emerging nano-electrochemical sensors
Author(s)	Murphy, Aidan; Hanley, Kathy; Creedon, Niamh; O'Riordan, Alan; O'Connell, Ivan
Publication date	2018-05
Original citation	Murphy, A., Hanley, K., Creedon, N., Riordan, A. O. and Connell, I. O. (2018) 'Advanced data acquisition for emerging nano-electrochemical sensors', 2018 IEEE International Instrumentation and Measurement Technology Conference (I2MTC), 14-17 May, Houston, Texas, pp. 1-6. doi: 10.1109/I2MTC.2018.8409766
Type of publication	Article (peer-reviewed) Conference item
Link to publisher's version	http://ieeexplore.ieee.org/document/8409766 http://dx.doi.org/10.1109/I2MTC.2018.8409766 Access to the full text of the published version may require a subscription.
Rights	© 2018 IEEE. Personal use of this material is permitted. Permission from IEEE must be obtained for all other uses, in any current or future media, including reprinting/republishing this material for advertising or promotional purposes, creating new collective works, for resale or redistribution to servers or lists, or reuse of any copyrighted component of this work in other works.
Item downloaded from	http://hdl.handle.net/10468/6640

Downloaded on 2019-09-21T13:47:46Z

Advanced Data Acquisition for Emerging Nano-Electrochemical Sensors

Aidan Murphy¹, Kathy Hanley¹, Niamh Creedon², Alan O’Riordan² and Ivan O’Connell¹

¹Microelectronics Circuits Center Ireland (MCCI), ²Nano-Technology Group (NTG),
Tyndall National Institute, Dyke Parade, Cork, Ireland
aidan.murphy@mcci.ie, ivan.oconnell@mcci.ie

Abstract—This paper describes a low cost portable point of test data acquisition system, made of commercial components, that was developed to interface to electrochemical sensors. The proposed system has demonstrated that it can support cyclic voltammetry, square wave voltammetry and collector generator voltammetry, with dual electrode control. The system has demonstrated its capability to detect a range of ferrocene monocarboxylic acid concentrations using nanowire electrochemical sensors, while benchmarking the results against dedicated laboratory based equipment. This work has identified and highlighted the unique challenges of interfacing to electrochemical sensors.

Keywords—Electrochemical Sensors, MATLAB, C++, Data Acquisition System, Sensors

I. INTRODUCTION

Some of the first electrochemical sensors were used for the detection of oxygen in blood in the 1950’s [1]. Since then, with advances in technology, and the continuously growing demand to measure and monitor a raft of factors that impact our day to day lives, their applications have spread to environmental [2], security [3], medical sensing [4].

At present, the majority of electrochemical sensing is performed in a laboratory environment. This method of diagnostics is both time consuming and expensive. Typically, a sample must be taken at the point of interest and then shipped to the chosen diagnostics laboratory. This jeopardies the integrity of the sample unless it is preserved in a known, stable and contained environment. Then, during the full diagnosis process, the sample is handled by a multitude of people, many of whom must be highly skilled. To reduce costs, some of these

tests are pooled, meaning further delays to identify which individual samples are positive. Once a result is obtained by the laboratory, it must be communicated efficiently, securely and appropriately back to the client. This is particularly important where the specific test being undertaken is a clinical test impacting an individual’s health. These processes typically take at least three working days. However, in addition to the sample capture, secure transport and actual test, there is a significant management overhead in relation to the tracking and management of individual samples to ensure that they are tested within an appropriate timeframe. If there is any unforeseen delay, it can result in unnecessary stress and the original issue developing such that the test results are no longer relevant.

A suitable method of addressing this problem is the proposed point of test diagnostic system as shown in Fig. 1. This system would act as an initial diagnostic tool for a range of electrochemical sensors, while providing rapid, relevant quantitative and qualitative data to enable appropriate action to be promptly taken. It would be an easily integratable field to cloud solution for field personnel, who are no longer required to be laboratory trained to obtain an initial result. The system may be of particular use in developing countries that do not have immediate access to appropriately laboratory equipment. Today other systems have been developed for a variety of individual specific applications. Examples of these include the advanced pregnancy tests, as shown in Fig. 2, and digital glucometers. Both are exemplary application specific examples but are not robust enough to work across a range of applications. Current laboratory equipment, such as the Autolab PGSTAT302N potentiostat [6] in Fig. 3, can work across a large range of applications but are expensive, difficult

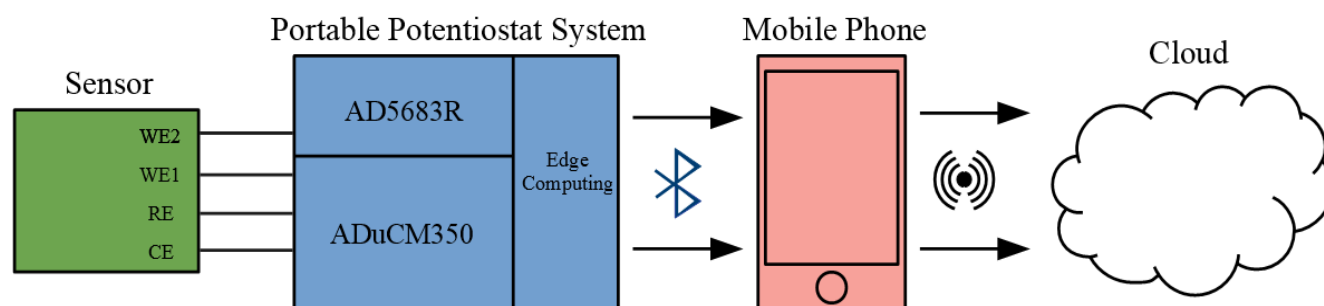

Fig. 1. Block diagram of envisaged final point of test, data acquisition system.



Fig. 2. Clearblue advanced pregnancy test [5].

to use, require skilled operators and don't readily support in-field testing.

One of the main challenges in this system resides at the interface between the sensor and the electronic measurement device. This work describes how a data acquisition system was developed to interface to the electrochemical sensors, which is robust enough to enable the sensors under test to be interrogated using a variety of different techniques, to realize a Portable Potentiostat System as illustrated in Fig 1. This enables the proposed system to support a variety of different sensors and end applications.

II. ELECTROCHEMICAL SENSORS

Electrochemistry is the science that investigates the charge transfer at the electrode solution interface [7]. A typical electrochemical sensor, as illustrated in Fig. 4, generates electron transfer when the target analyte is present in the solution and a voltage potential is inferred at the working electrode (WE), via the counter electrode (CE). This electron flow results from the induced redox action, whereby the molecule of interest in the solution either loses an electron (oxidises) or gains an electron (reduces) under the applied potential. The counter electrode which induces a potential, which is seen at the working electrode, also acts as a source/sink of electrons to enable the reaction. The current measured at the working electrode is a direct measure of the chemical reaction and is representative of the concentration of the target analyte present in the solution. In electrochemical reactions, it is important to maintain an accurate voltage at the working electrode. For electrolytes with large solution resistances or reactions with large currents a potential drop can



Fig. 3. Laboratory based tabletop potentiostat, the Autolab PGSTAT302N.

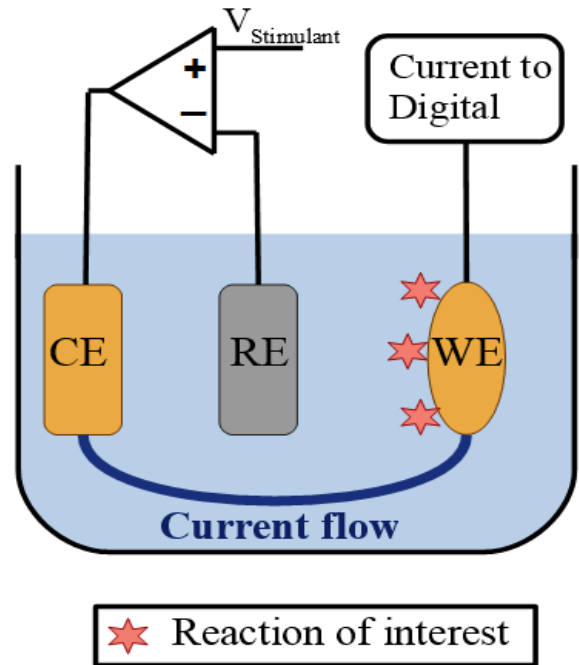
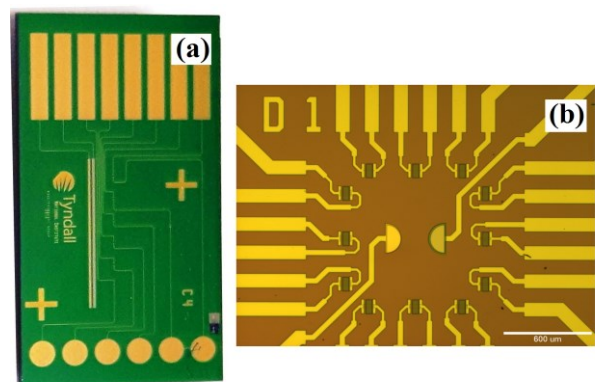

Fig. 4. Simple Three Electrode Electrochemical sensor.

occur between the counter and working electrodes. To counteract this, a third non-polarisable electrode is often used, the reference electrode (RE). It enables an accurate potential to be maintained at the working electrode, as depicted in Fig. 4.

For a variety of applications, electrochemical sensors have already established themselves as the sensor of choice, initially in the area of indoor air quality, but more recently in the area of home diagnostics kits, such as pregnancy kits and glucose monitoring. Electrochemical sensors typically have the required specificity to enable low detection levels, without comprising the fast response which is required for health and safety monitoring in hazardous environments. This combined with their low cost, makes them particularly suited to single use, portable, point of test applications.



(a) Nanowire sensor on chip (b) Interdigitated sensor, used for collector generator voltammetry

Fig. 5. Electrochemical sensors developed in Tyndall that will be used as the target application for the system.

TABLE I. REQUIREMENTS FOR POINT OF TEST DATA ACQUISITION SYSTEM

Parameter	Requirement
Portability	Handheld device
Cost	100-500\$
Speed	<1min
Required tests	Cyclic Voltammetry, Square Wave Voltammetry, Collector Generator
Sensitivity	Minimum 50pA resolution

The Nanowire electrochemical sensors, shown in Fig. 5, have been developed in the Tyndall National Institute, Cork, Ireland [8-11]. These sensors offer many advantages over existing sensors, specifically in terms of their response time resulting from their feature size [12]. This makes these sensors, particularly suited for field deployment for point of test applications for an optimum sensitivity response time solution.

III. SYSTEM REQUIREMENTS

To enable in-field deployment of electrochemical sensors, a portable data acquisition system platform needs to be developed that has comparable accuracy to dedicated laboratory based instrumentation. It must also have the required robustness to support different interrogation methods and at the same time, withstand the physical challenges of deployment to the field, for use by unskilled operators.

Using the Tyndall developed nanowire sensors as a lead example, a requirements table was derived for this data acquisition system. As presented in Table I, an inexpensive portable system was required that could quickly perform, with similar accuracy to a laboratory potentiostat, a variety of voltammetric analysis techniques, which will be described in the remainder of this section.

Voltammetry is a popular class of test used to interrogate electrochemical sensors. Voltammograms involve maintaining

a DC potential between the Working Electrode and Reference Electrode in the sensor, while also measuring the resultant current output at the WE. A potentiostat is the instrument used to perform voltammograms. A derivative of the potentiostat is the bipotentiostat, this instrument accommodates for the control of an extra working electrode, which is necessary to complete Collector Generator voltammograms as illustrated in Fig. 6 (b) and discussed in more detail later in this section.

Cyclic Voltammetry [13], is a voltammetric technique where a reverse voltage sweep is inferred at the working electrode with respect to the reference electrode as shown in Fig. 6 (a). It is one of the most popular electroanalytic techniques in use today. Its peak current can reflect the concentration of the target substance. It is also used to investigate the reversibility of the chemical reaction, the electron kinetics of the electrode solution interface and the presence of intermediates in reactions [14].

Collector generator voltammetry [15] is a technique that requires two working electrodes and is typically used to enable enhanced sensitivity of the sensor under test. The first working electrode (WE1), the generator, is used to perform a voltammetric test. The second working electrode (WE2), the collector, is held at a potential with respect to WE1, as illustrated in Fig. 6 (b), this converts the species generated at WE1 back to what it was initially. This technique often enhances the sensitivity of the generator electrode due to the improved replenishment of the species of interest to its surface.

Square Wave Voltammetry [16], involves applying a ramped square wave to the sensor and measuring the difference in current at the end of the trough and peak of each period, as shown in Fig. 6 (c). Square wave voltammetry is a sensitive electroanalytic technique and is more likely to be used for lower concentration detection as its peaks can be an indicator of the concentration of the species of interest as well. The voltage levels for each of these tests are displayed in Fig. 7.

IV. PORTABLE ELECTROCHEMICAL DATA ACQUISITION SYSTEM

The proposed data acquisition system is presented in Fig. 8. This is realized using the ADuCM350, a configurable on chip potentiostat with an integrated ARM microprocessor

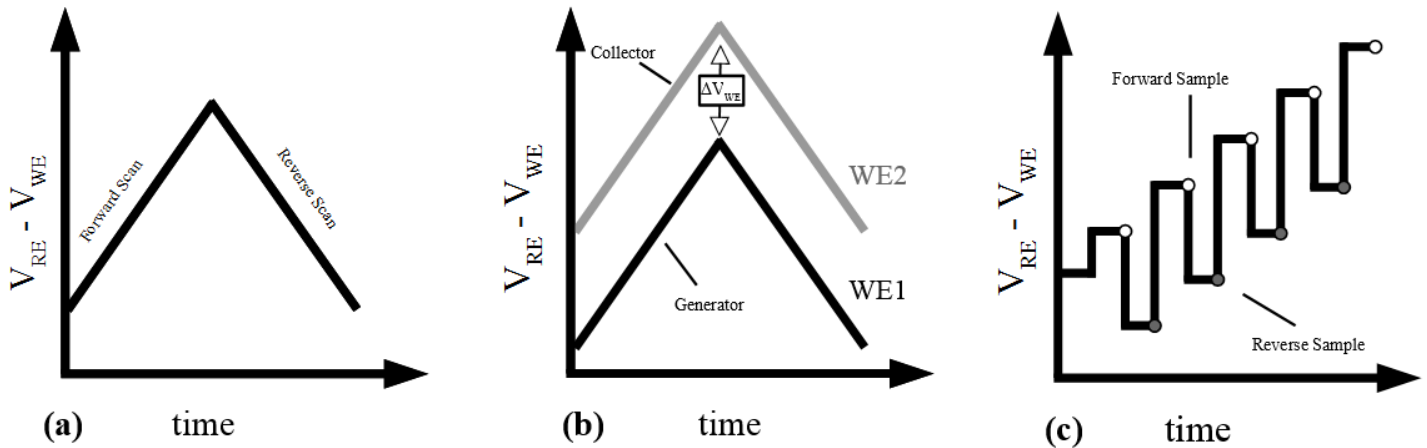

(a) Cyclic Voltammogram, (b) Collector Generator Cyclic Voltammetry where the potential difference held between the two electrodes is seen by ΔV_{WE} , (c) Square Wave Voltammogram depicting forward and reverse sample points

Fig. 6. Voltages applied by potentiostat, between the WE and RE, varying with different voltammetric techniques.

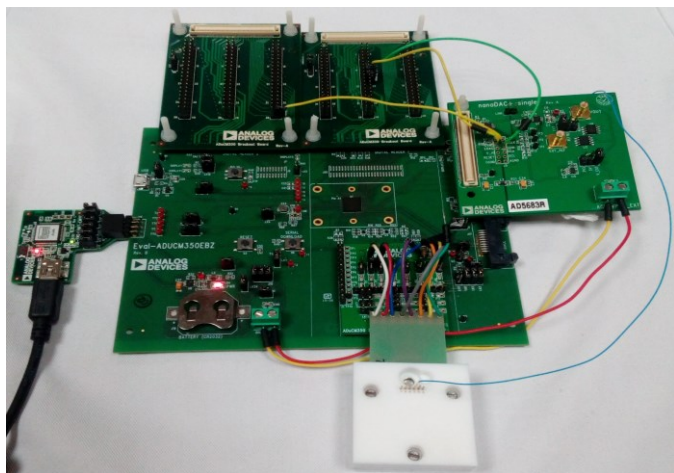

Fig. 7. System interfacing with electrochemical sensor.

from Analog Devices [17], a breakout board and a 16 bit Digital to Analog Converter (DAC), the AD5683R [18].

Embedded C++ programmes were developed and configured using the IAR Embedded Workbench [19]. These scripts enable the electrochemical sensor under test to be appropriately configured and biased for the different modes of operation, specifically: (a) Cyclic Voltammetry, (b) Square Wave Voltammetry and (c) Collector Generator. The rate at which the voltammetric test would sweep through the designated voltage range, the scan rate, and the frequency of square wave voltammograms can be configured on the scripts. For each voltammogram, the WE was maintained at a virtual ground of 1.1 V. The data acquisition system was programmed to apply an appropriate potential to the counter electrode relative to the reference electrode, so the desired potential at the working electrode was inferred. Prior to each voltammogram, a potential of 0 V was applied at the WE. This was done to accommodate for settling of the system and to active the electrode surface prior to test. A current reading was also taken while the 0 V was being applied, this was used as the corresponding 0 A reference value for the subsequent test.

A limitation of the ADUCM350 is that it is only capable of stimulating one working electrode at a time. Hence a separate DAC, the AD5683R, is required to bias the second working electrode. The specific configuration for the Collector Generator is illustrated in the block diagram Fig 8, where the ADUCM350 is configured to measure the resultant current, while appropriately biasing CE through its own internal DAC. The AD5683R acts as a floating voltage source, keeping a constant voltage between the CE and WE2. Serial Peripheral Interface is the protocol used to enable master slave communication between the two chips and ensure a constant potential is maintained between the two electrodes. This method of achieving dual potential control was inspired by Bard [20].

The C++ code is run using the IAR embedded workbench, Analog to Digital Converter (ADC) codes are transmitted through Universal Asynchronous Receiver-Transmitter via

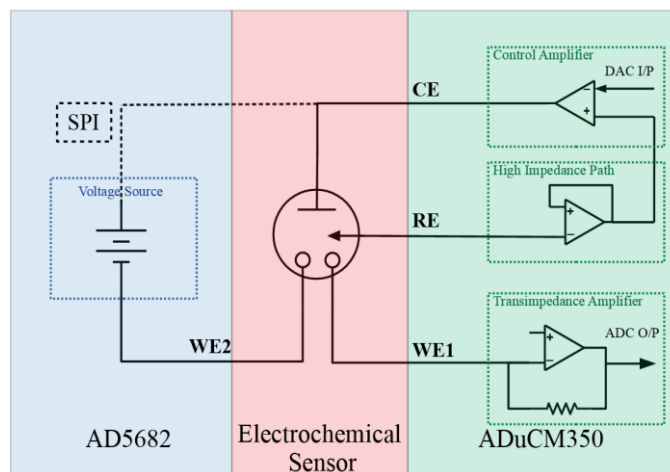

Fig. 8. Circuit diagram representing system operating Collector Generator test.

com ports and displayed using putty. This data is processed using MATLAB code, which is subsequently plotted on excel.

V. RESULTS

To calibrate the system, a cyclic voltammogram was performed using a 100 M Ω resistance as shown in Fig. 9 (a). This is a useful way to ascertain whether the proposed data acquisition system is fit for purpose while also removing electrochemical noise. For comparison, a cyclic voltammetry scan was also performed on the 100 M Ω resistance using a laboratory grade tabletop potentiostat, the Autolab PGSTAT302N, with an additional module [21] to enable collector generator measurements. For Autolab based measurements device under test was placed inside a faraday cage, to negate the potential effects of any electromagnetic noise. Little discrimination was seen between the two scans, as seen from Fig. 9 (a). According to the laboratory potentiostat, the resistance measured out to be 99.88 M Ω , whereas the ADuCM350 measured 99.47 M Ω , resulting in an average error of 410 k Ω or better than or better than 0.5 % accuracy. The performance of the chip was deemed acceptable for measuring currents in the 0 - 100 nA range.

To further validate the proposed electrochemical data acquisition system, a number of voltammetry scans were performed on different electrochemical sensors using ferrocene monocarboxylic acid (FcCOOH). FcCOOH is a suitable compound as it's routinely used to characterize electrochemical sensors [10]. These results were repeated using the Autolab equipment, to benchmark the proposed data acquisition system. Voltammetry scans were performed, whereby the applied potential was swept from -0.2 V to 0.6 V, as typical for interrogating nanowire electrochemical sensors detecting FcCOOH.

Cyclic voltammetry scans were performed for 5 different FcCOOH concentrations on both the laboratory potentiostat and proposed data acquisition system. To allow for consistency, each test was performed on the Autolab first and subsequently on the proposed system. When examining cyclic voltammetry curves two of the main points of interest were the

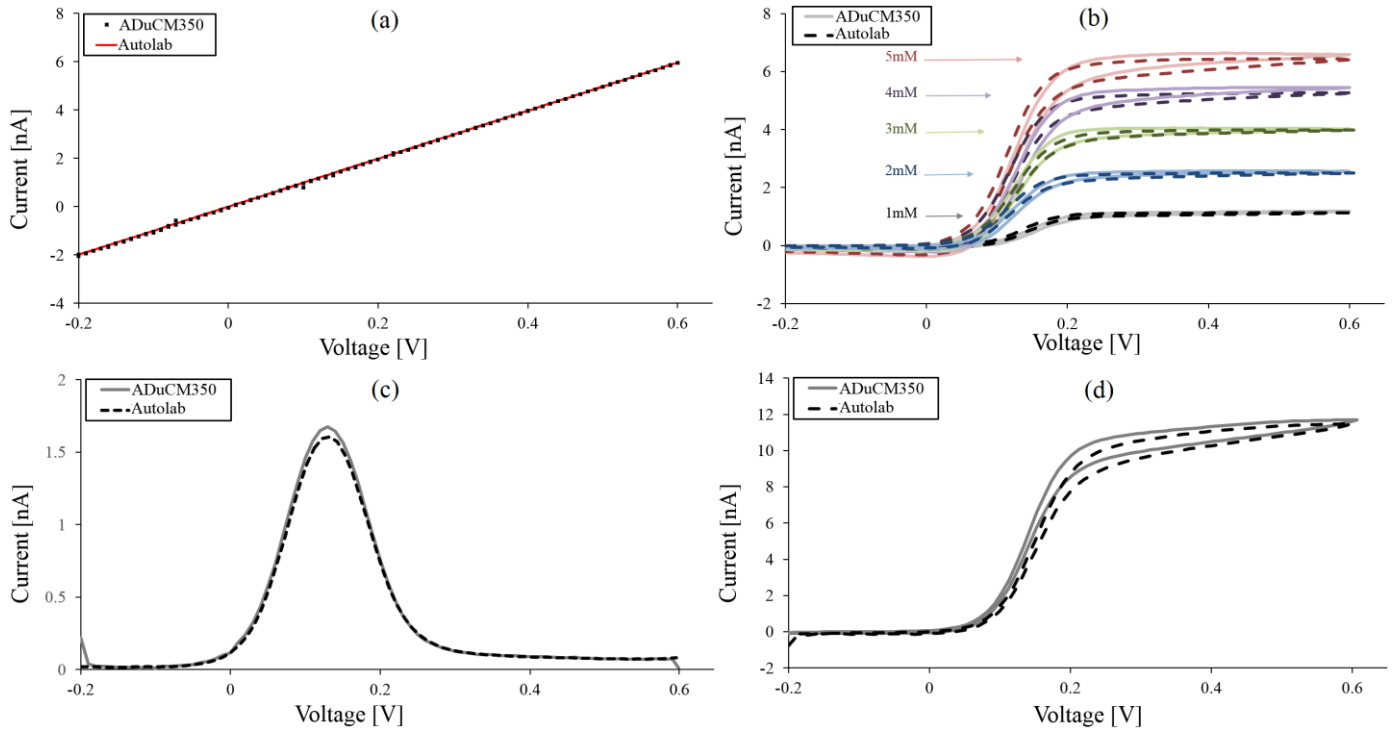

(a) Cyclic voltammety scan testing system using $100\text{M}\Omega$ resistor, swept at 100mV/s , (b) Cyclic voltammety scan measuring varying concentrations of FcCOOH using nanowire sensor, swept at 100mV/s , (c) Square wave voltammogram at 10Hz , swept at 100mV/s of 1mM FcCOOH using microband sensor, (d) Collector Generator of 1mM FcCOOH using an interdigitated microband sensor, swept at 100mV/s

Fig. 9. Calibration of system against tabletop potentiostat.

peak current and the redox potential. For FcCOOH, the peak current is an indicator of its concentration of in the solution while, the redox potentials, which are the points where the curve enters and leaves steady state, should be between 0 and 0.2 V for the on chip reference electrode. The peak currents varied by up to 4 % between the two potentiostats, while the redox potentials varied by up to 5 mV, which is deemed acceptable. This demonstrated the ability of the proposed low cost electrochemical data acquisition system to produce results comparable to dedicated laboratory instrumentation across a large range of detection levels, as shown in Fig. 8 (b). A square wave voltammogram was performed electrode to demonstrate that different voltammetric tests could be executed using the proposed system, as illustrated in Fig. 9 (c). A difference in peak current magnitude of 68 pA was measured when compared to the Autolab potentiostat, this is considered to be within an acceptable margin of error. The system could also control two electrodes of an electrochemical sensor with similar accuracy to a benchtop potentiostat, as outlined in Fig. 9 (d). Here, the reduction potential varied by 10 mV and the peak current amplitude varied by 221 pA.

All the measured results agreed well with the laboratory potentiostat given that variations will occur with scans performed on the same electrode due to the repeatability of electrochemical sensors. Factors that may have contributed to the difference were polarization of the pseudo reference electrode and the deposition of FcCOOH on the electrode surface. The performance of the proposed systems is summarized in Table II.

VI. CONCLUSION

A low cost, portable point of care data acquisition platform has been developed and demonstrated which is suitable to interface with a range of electrochemical sensors. Results have shown accuracies comparable to a table top, laboratory based potentiostat for three different types voltammetric analysis techniques. The cyclic voltammety calibration showed the system's ability to differentiate between different concentrations of FcCOOH clearly.

Future work includes the development of a PCB to future minuterise the electrochemical acquisition system, reducing the form factor.

TABLE II. SPECIFICATIONS OF SYSTEM

Potentiostat	Yes
Floating (Isolated from Earth Ground)	Yes
Cell Connections	2,3,4 (+ Bipotentiostat)
Maximum Current	100nA
Current Ranges	1
Current Resolution	35pA
Max Applied Potential	$\pm 1.1\text{V}$
Max Scan Rate	200mV/s
Weight	<1kg
Dimensions	20(W)x20(L)x5(H) cm

ACKNOWLEDGEMENT

The authors would like to thank Analog Devices Limerick for providing evaluation boards and their technical support.

This publication has emanated from research conducted with the financial support of Science Foundation Ireland (SFI) and is co-funded under the European Regional Development Fund under Grant Number 13/RC/2077.

VII. REFERENCES

- [1] J. L.C.Clark, "Monitor and Control of Blood and Tissue Oxygen Tensions," *American Society for Artificial Internal Organs*, vol. 2, no. 1, pp. 41-48, Apr. 1956.
- [2] Pankaj Ramnani et al., "Carbon nanomaterial-based electrochemical biosensors for label-free sensing of environmental pollutants," *Chemosphere*, vol. 143, pp. 85-98, Jan. 2016.
- [3] J. Wang, "Electrochemical Sensing of Explosives," *Electroanalysis*, vol. 19, no. 4, pp. 415-423, Jan. 2017.
- [4] A. C. a. S. Chatterjee, "Nanomaterials based electrochemical sensors for biomedical applications," *Chemical Society Reviews*, vol. 42, no. 12, pp. 5425-5438, Dec. 2012.
- [5] Clearblue, "Clearblue Digital Pregnancy Test with Weeks Indicator." [Online]. Available: http://uk.clearblue.com/sites/default/files/hcp_cb9_professional_brochure.pdf. [Accessed: 08-Dec-2017]
- [6] Metrohm Autolab, "Autolab PGSTAT302N - High Performance," [Online]. Available: <http://www.metrohm-autolab.com/Products/Echem/NSeriesFolder/PGSTAT302N>. [Accessed 6 12 2017].
- [7] C. G. Zoski, *Handbook of Electrochemistry*, Amsterdam: Elsevier, Dec. 2007.
- [8] Karen Dawson et al., "Fully integrated on-chip nano-electrochemical devices for electroanalytical applications," *Electrochimica Acta*, vol. 115, pp. 239-246, Jan. 2014.
- [9] Karen Dawson et al., "Single on-chip gold nanowires for electrochemical biosensing of glucose," *Analyst*, vol. 136, no. 21, pp. 4507-4513, Aug. 2011.
- [10] Karen Dawson et al., "Electroanalysis at Single Gold Nanowire Electrodes," *The Journal of Physical Chemistry*, vol. 116, no. 27, p. 14665-14673, Jun. 2012.
- [11] James Rohan et al. "Interdigitated Nanoelectrode Arrays for Enhanced Sensitivity. Electrochemical Society Meeting". In Proc. Electrochemistry Society Meeting, Orlando, Florida, May 2014.
- [12] D. W. M. Arrigan, "Nanoelectrodes, nanoelectrode arrays and their applications," *Analyst*, vol. 129, pp. 1157-1165, Nov. 2004.
- [13] Noemie Elgrishi et al., "A Practical Beginner's Guide to Cyclic Voltammetry," *Journal of Chemical Education*, vol. ASAP, Nov. 2017.
- [14] R. S. Nicholson, "Theory and Application of Cyclic Voltammetry for Measurement of Electrode Reaction Kinetics," *Analytical Chemistry*, vol. 37, no. 11, pp. 706-723, Oct. 1965.
- [15] Edward O. Barnes et al., "Generator-collector double electrode systems: A review," *The Royal Society of Chemistry*, vol. 137, no. 5, pp. 1068-1081, Jan. 2012.
- [16] L. Ramaleu, "Theory of square wave voltammetry," *Analytical Chemistry*, vol. 41, no. 11, pp. 1362-1365, Jun. 1969.
- [17] Analog Devices, "16-Bit Precision, Low Power Meter On A Chip with Cortex-M3 and Connectivity", ADuCM350 datasheet, May 2014 [Revised May 2017].
- [18] Analog Devices, "Tiny 16-/14-/12-Bit SPI nanoDAC+, with ± 2 (16-Bit) LSB INL and 2 ppm/ $^{\circ}$ C Reference" AD5683R datasheet, Dec. 2013 [Revised Dec. 2016].
- [19] IAR Systems, *IAR Embedded Workbench 7.5*, Sweden, Nov. 2015.
- [20] L. R. Allen J. Bard, "Electrochemical Methods Fundamentals and Applications 2nd ed.," in *Methods Involving Forced Convection - Hydrodynamic Methods*, Austin, John Wiley & Sons, Jan. 2001, pp. 350-351.
- [21] Metrohm Autolab, "BA - Dual mode bipotentiostat module," [Online]. Available: <http://www.metrohm-Autolab.com/Products/Echem/ModulesFolder/BA.html>. [Accessed 6 12 2017].