

|                                    |  |
|------------------------------------|--|
| <b>Title</b>                       | Real-time equilibrium reconstruction integration into the ASDEX Upgrade control system   |
| <b>Author(s)</b>                   | Giannone, L.; Sieglin, B.; Fischer, R.; Fuchs, J. C.; McCarthy, Patrick J.; Schuhbeck, K. H.; Treutterer, W.; ASDEX Upgrade Team   |
| <b>Publication date</b>            | 2018-07  |
| <b>Original citation</b>           | Giannone, L., Sieglin, B., Fischer, R., Fuchs, J. C., McCarthy, P. J., Schuhbeck, K. H., Treutterer, W. and the ASDEX Upgrade Team (2018) 'Real-time equilibrium reconstruction integration into the ASDEX Upgrade control system', 45th European Physical Society Conference on Plasma Physics Prague, Czech Republic, 2-6 July, P2.1041 (4pp). Available at: <a href="http://ocs.ciemat.es/EPS2018PAP/pdf/P2.1041.pdf">http://ocs.ciemat.es/EPS2018PAP/pdf/P2.1041.pdf</a> (Accessed: 11 January 2019) |
| <b>Type of publication</b>         | Conference item  |
| <b>Link to publisher's version</b> | <a href="http://ocs.ciemat.es/EPS2018PAP/pdf/P2.1041.pdf">http://ocs.ciemat.es/EPS2018PAP/pdf/P2.1041.pdf</a><br>Access to the full text of the published version may require a subscription.  |
| <b>Rights</b>                      | © 2018, the Authors. This paper is made available under the terms of the Creative Commons Attribution (CC BY) licence, which allows others to freely access, use, and share the work, with an acknowledgement of the work's authorship and its initial presentation at 45th European Physical Society Conference on Plasma Physics (2018).<br><a href="https://creativecommons.org/licenses/by/3.0/">https://creativecommons.org/licenses/by/3.0/</a>  |
| <b>Item downloaded from</b>        | <a href="http://hdl.handle.net/10468/7286">http://hdl.handle.net/10468/7286</a>  |

Downloaded on 2019-01-23T11:51:10Z



**UCC**

University College Cork, Ireland  
Coláiste na hOllscoile Corcaigh

## **Real-time equilibrium reconstruction integration into the ASDEX Upgrade control system**

L.Giannone, B.Sieglin, R.Fischer, J.C.Fuchs, P.J.McCarthy<sup>1</sup>,

K.H.Schuhbeck, W.Treutterer and the ASDEX Upgrade Team

*Max Planck Institute for Plasma Physics, EURATOM Association, 85748 Garching, Germany*

<sup>1</sup>*Department of Physics, University College Cork, Association EURATOM-DCU, Cork, Ireland*

### **Abstract**

The real-time equilibrium reconstruction code for the ASDEX Upgrade tokamak, JANET [1], is in the process of migration to a Linux based C11++ code. This is motivated by the need for closer integration into the ASDEX Upgrade control system and the long term goal of replacing the currently used function parameterisation based control when upper divertor coils for studying advanced magnetic configurations are installed [2].

### **Introduction**

Real-time control of a tokamak discharge using cyclic reduction to solve the Grad-Shafranov equation was originally demonstrated on Doublet III-D [3]. A Grad-Shafranov solver for a multicore CPU with improved performance has been reported [4]. This algorithm has been modified so that only a single discrete sine transform and inverse discrete sine transform is necessary [1]. A parallel Grad-Shafranov solver using a graphic processing unit (GPU) for the control system of EAST has also been developed. The P-EFIT code is built with the CUDA architecture to take advantage of the large number of parallel GPU cores [5].

### **Data acquisition and control system**

The position and orientation of the magnetic probes and flux loops, the position of the poloidal field coils and limiters and the surface locations of the 7 rows of ferromagnetic tiles installed in 2017 are input from an XML based machine description file. Recently developed analog integration electronics with 16 bit analog-to-digital converters, record data at a sample frequency of 20 kHz. The integrator output has a 10 kHz low pass filter. The integration time constant is measured before every discharge. A chassis with 16 channels is connected to one of four ports of a PXIe 7821 digital input/output module. On board memory of 512 megabytes allows the data acquired for 64 channels for a time interval up to 200 s to be stored locally while providing real-time data at a reduced sampling frequency to the control system. The recorded data is transmitted in real-time by an optical bus extender (MXI Express x4) to the computing node with an 8 core Intel Xeon E5-2667 v3 running at 3.2 GHz. Presently 96 magnetic

probes and flux loops are connected. This extends the measurement capability to five toroidally separated poloidal arrays and two toroidally separated diamagnetic flux loops.

The control system runs C++ code on a Linux multicore computer. The cycle time for feedback control is currently 1 ms. There exists also physical limits to discharge control as the power supplies for feedback control of vertical plasma position are limited to a 1 kHz bandwidth. Additionally, the vacuum vessel acts as a low pass filter. Consequently, above 100 Hz the higher frequency components are attenuated and vertical position control on a fast time scale is limited. A real-time equilibrium reconstruction code that completes the required calculations in a time less than 0.5 ms will be therefore adequate for discharge control on ASDEX Upgrade.

## Benchmarks

Shown in Fig. 1 are the benchmarks of the individual elements of the real-time Grad-Shafranov solver. The execution time in microseconds for every step of the algorithm is shown in brackets. The matrix-matrix and matrix-vector operations use single threaded Intel Math Kernel Library, MKL, functions.

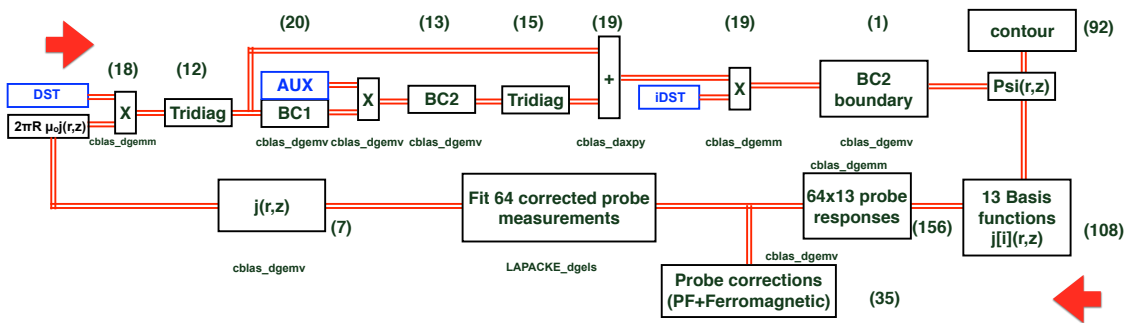

Figure 1: Benchmarks of the individual elements of the real-time Grad-Shafranov solver. Shown in brackets is the execution time in microseconds for every step of the algorithm. The matrix-matrix and matrix-vector operations use the single threaded MKL library.

On a  $65 \times 129$  grid, the Grad-Shafranov solver then calculates a flux matrix,  $\psi(R,Z)$ , that is a best fit to the magnetic probe measurements in  $117 \mu\text{s}$ . The setting up of the 13 basis current functions on the flux matrix from the previous time step requires  $108 \mu\text{s}$ . The calculation of the magnetic probe responses for these basis current functions requires  $156 \mu\text{s}$ . This slowest step calculates the 64 magnetic probe responses by using precalculated Green's functions for every current element on the grid. Therefore a  $64 \times 8001$  matrix and  $8001 \times 13$  matrix multiplication is needed. If necessary, this execution time can be reduced by using a parallel version of the matrix-matrix multiplication. The total time for completion of a single cycle is  $388 \mu\text{s}$ . In the original [3] and this real-time version of the equilibrium reconstruction algorithm, only a single iteration for a given time step of magnetic probe data is performed. An interpolation routine

on 16 grid points is used to find the magnetic axis and the X-points of the divertor magnetic configurations. The measured currents in each of the poloidal field coils is used rather than being fitted. It is necessary to subtract the poloidal field coil and ferromagnetic tile contributions to the magnetic probe measurements before they are used to determine the best fit coefficients of the current basis functions.

The benchmark for the GPU based system on EAST is 375  $\mu$ s on a  $129 \times 129$  grid [5]. In this real time version of the equilibrium reconstruction algorithm, a number of iterations for a given time step of magnetic probe data is performed.

### **Contouring**

The contouring algorithm finds the co-ordinates on the lines joining the grid points with the same value of the flux matrix solution of the Grad-Shafranov equation. Vector sums, vector multiplications and dot products are performed with MKL functions. Contour integrals at 10 normalised radii required for input to the RAPTOR code [6] and at the separatrix to calculate beta poloidal and plasma inductance from the Shafranov integrals are carried out in 92  $\mu$ s. If necessary, this execution time can be improved by starting parallel processes for each of the 10 contour integrals.

### **Internal diamagnetic flux**

The operation of the external diamagnetic loop in ASDEX Upgrade has a limited bandwidth of operation owing to the low pass filtering effect of the vacuum vessel [7]. The improvement in bandwidth when using internal measurement and compensation loops is the motivation for bringing the internal diamagnetic flux measurement into operation. The internal measurement loop is a single winding in the poloidal direction around the inside of the vacuum vessel. The compensation loop is one of two magnetic probes with orientation in the toroidal field direction. There are two sets of measurement and compensation loops separated by 180 degrees in the toroidal direction. In Fig. 2, the measured diamagnetic flux is compared to that predicted by the TRANSP simulation. The diamagnetic flux measurements are mostly in good agreement with the values calculated from the real-time and offline magnetic equilibrium reconstruction codes. This measurement will be used as a constraint for real-time equilibrium reconstruction.

### **Conclusion**

The first steps towards migrating the equilibrium reconstruction software to Linux C11++ code indicate that satisfactory performance with a single CPU core can be achieved.

This work has been carried out within the framework of the EUROfusion Consortium and has received funding from the Euratom research and training programme 2014-2018 under grant agreement No 633053. The views and opinions expressed herein do not necessarily reflect those of the European Commission.

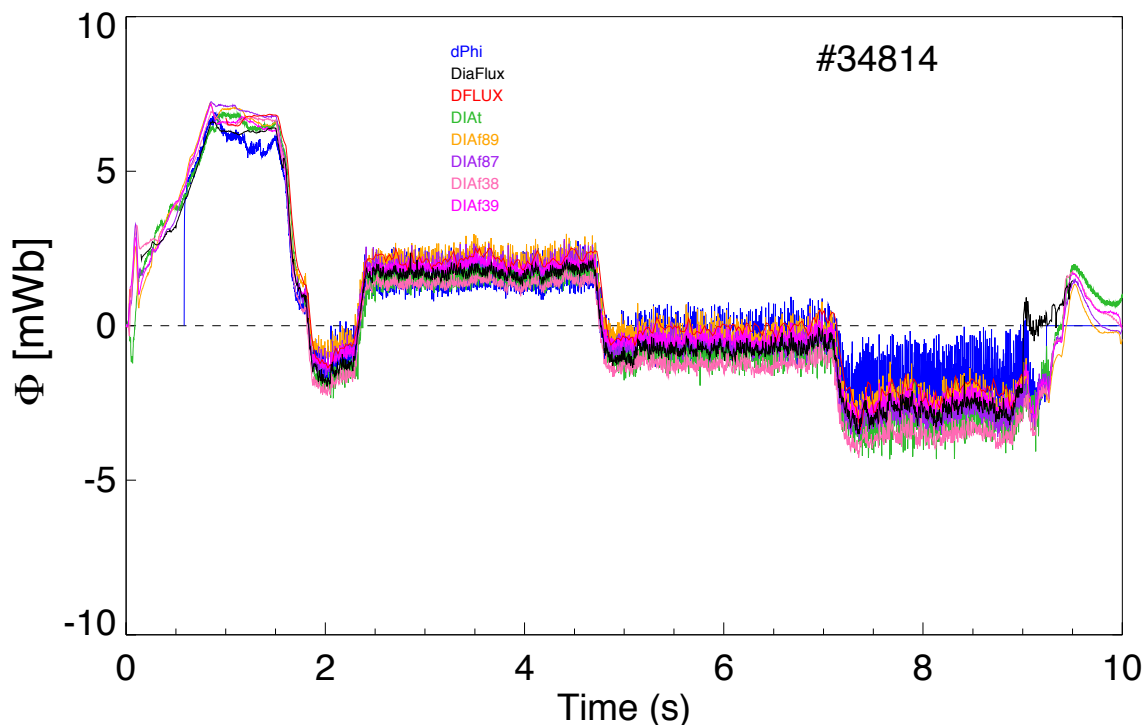

Figure 2: Comparison of diamagnetic flux calculations and measurements. The predicted value from TRANSP (DFLUX), the calculated values from the real-time equilibrium reconstruction (dPhi) and offline equilibrium reconstruction (DiaFlux) and the external (DIAI) and 4 internal (DIAf89, DIAf87, DIAf38, DIAf39) diamagnetic flux measurements are in good agreement.

## References

- [1] L. Giannone, M. Reich, M. Maraschek, et al., A data acquisition system for real-time magnetic equilibrium reconstruction on ASDEX Upgrade and its application to NTM stabilization experiments, *Fusion Eng. Des.* 88 (2013) 3299.
- [2] T. Lunt, H. Zohm, A. Herrmann, et al., Proposal of an alternative upper divertor in ASDEX Upgrade supported by EMC3-EIRENE simulations, *Nucl. Mat. and Energy* 12 (2017) 1037.
- [3] J. Ferron, M. Walker, L. Lao, H. E. St. John, D. Humphreys, J. Leuer, Real time equilibrium reconstruction for tokamak discharge control, *Nucl. Fusion* 38 (1998) 1055.
- [4] M. Rampp, R. Preuss, R. Fischer, ASDEX Upgrade Team, GPEC, a real-time capable tokamak equilibrium code., *Fusion Sci. Technol.* 70 (2016) 1.
- [5] Y. Huang, B.-J. Xiao, Z.-P. Luo, Q. Yuan, Improvement of GPU parallel real-time equilibrium reconstruction for plasma control, *Fusion Eng. Des.* 128 (2018) 82.
- [6] F. Felici, O. Sauter, S. Coda, et al., Real-time physics-model-based simulation of the current density profile in tokamak plasmas, *Nucl. Fusion* 51 (2010) 083052.
- [7] L. Giannone, B. Geiger, R. Bilato, et al., Real-time diamagnetic flux measurements on ASDEX Upgrade, *Rev. Sci. Instrum.* 87 (2016) 0503509.