

UCC Library and UCC researchers have made this item openly available. Please [let us know](#) how this has helped you. Thanks!

Title	Comparative analysis of circuit and finite element models for a linear wire dipole antenna
Author(s)	Kumar, Sanjeev; Buckley, John; Di Serio, Adolfo; O'Flynn, Brendan
Publication date	2018-12-24
Original citation	Kumar, S., Buckley, J. L., Di Serio, A. and O'Flynn, B. (2018) 'Comparative analysis of circuit and finite element models for a linear wire dipole antenna', 29th Irish Signals and Systems Conference (ISSC), Belfast, UK, 21-22 June. doi:10.1109/ISSC.2018.8585353
Type of publication	Conference item
Link to publisher's version	https://ieeexplore.ieee.org/document/8585353 http://dx.doi.org/10.1109/ISSC.2018.8585353 Access to the full text of the published version may require a subscription.
Rights	© 2018, IEEE. Personal use of this material is permitted. Permission from IEEE must be obtained for all other uses, in any current or future media, including reprinting/republishing this material for advertising or promotional purposes, creating new collective works, for resale or redistribution to servers or lists, or reuse of any copyrighted component of this work in other works.
Item downloaded from	http://hdl.handle.net/10468/7532

Downloaded on 2021-09-17T09:34:52Z

Comparative Analysis of Circuit and Finite Element Models for a Linear Wire Dipole Antenna

Sanjeev Kumar, John L. Buckley, Adolfo Di Serio, Brendan O'Flynn
Wireless Sensor Networks Group, Tyndall National Institute,
University College Cork, Cork, Ireland
Email: sanjeev.kumar@tyndall.ie

Abstract—Antennas are a critical component of an internet of things device and are typically modelled using full-wave electromagnetic (EM) solvers for their optimal design. In this paper, we investigate and compare the impact, accuracy and limitations of three, four and five element equivalent circuit models from the literature to estimate the impedance characteristics of a centered linear wire dipole antenna at 2.45 GHz. All the circuit model results are compared against the finite element model. It was found that the three element model is inaccurate in estimating the input impedance of a dipole antenna at the resonant frequency. In comparison to the finite element model, the four element model estimates the input impedance with an error of $3.75 - j2.54$ Ohms at 2.45 GHz. For the five element model the error in the input impedance was $-6.21 + j1.68$ Ohms. The input impedance for the both, the four and five element models are in good agreement with the EM model. This approach is shown to enable efficient analysis of antenna impedance for wireless communication systems.

Keywords—Input impedance, dipole antenna, equivalent circuit, FEM and circuit models.

I. INTRODUCTION

Recently, the development of low energy devices including wireless sensors and distributed antenna systems has attracted increasing attention [1]. For a low energy wireless ecosystem, it is required to minimize the energy needed to acquire information and transmit it to other devices [2]. Wireless technologies incorporating an antenna radiate efficiently when the reflected power from the antenna is minimum. The input impedance of the antenna ($Z_{in} = R_{in} + jX_{in}$) is a fundamental design parameter which determines the reflection coefficient, bandwidth and the quality factor of the antenna [3]. The impedance characteristics of an antenna are generally analysed using full-wave electromagnetic (EM) solvers based on the different computation methods such as the finite element method (FEM) and the method of moments (MoM). However, it is convenient to represent the impedance characteristics of an antenna using equivalent circuit models. The EM model takes more computational time than the circuit model, as the EM solvers such as FEM based HFSS divides the antenna structure into a large mesh and solve the Maxwell's equations for each of them [18]. The input impedance and the resonant frequency (f_0) of a dipole antenna fundamentally depends on its length [3, 7]. A dipole antenna can be represented in terms of lumped circuit elements, where the value of these elements are related to the physical dimension of the antenna

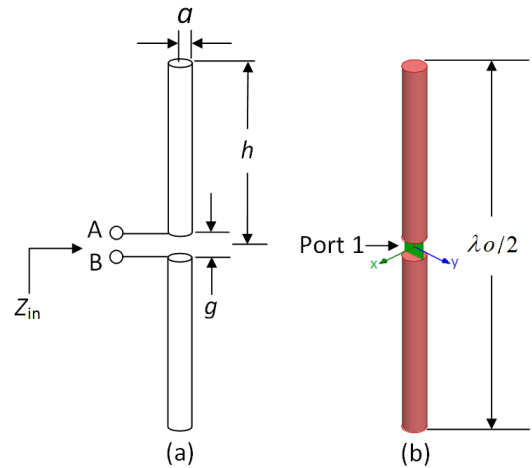

Fig. 1: (a) A center-fed linear wire dipole antenna, (b) FEM model for comparison.

[5–9]. As the dipole antenna is a fundamental structure, and a large number of IoT, RFID and wireless sensor devices use dipole topology [10–14], in this study the equivalent circuit models of a dipole antenna are analysed. Fig. 1 (a) shows a center-fed linear wire dipole antenna where, a is the radius of the wire, h is the half-length [6, 8], g is the feed gap-size and A & B are the two input terminals of the dipole. Fig. 1 (b) represents the FEM model of a lossless dipole antenna where port 1 is the feed point and $\lambda_0/2$ is the overall length of the dipole. The purpose of this paper is to investigate the impact, accuracy and limitations of the various equivalent circuit models in the literature for a practical linear wire dipole antenna at 2.45 GHz. The empirical formulas are included for all the equivalent circuit elements. The values of the circuit elements were calculated at the specified resonant frequency, $f_0 = 2.45$ GHz for a half-wavelength ($2h = \lambda_0/2$) linear wire dipole antenna where, $\lambda_0 = c/f_0 = 122.45$ mm and c is the speed of light in free space (m/s). Therefore, the dipole half-length, $h = \lambda_0/4 = 30.61$ mm. In this work, the performance characterization of the three, four and five element equivalent circuit models for a dipole antenna of fixed radius, $a = 0.5$ mm have been analysed through AWR Microwave Office circuit simulation [17] and Ansys HFSS full-wave EM simulation [18].

II. METHODOLOGY

A considerable amount of literature has been reported on the equivalent circuit modelling of a linear wire dipole antenna for the estimation of Z_{in} . These include the three element model by Chu, three and four element model by Tang, the four element model by Streable and the five element model by Hamid [4–7]. In this paper, accuracy refers to the closeness in the impedance characteristics of a dipole antenna obtained from the FEM and the circuit model. Investigation of the accuracy of the different circuit models against FEM solvers is useful in predicting the input impedance and the resonant frequency of a dipole antenna for practical applications. The feed-gap size, $g = 1$ mm has been selected for the FEM model simulation. As in practice most of the dipole antennas are designed to operate at or near their first resonant frequency, the higher order modes are ignored [6, 8, 9].

III. RESULTS AND DISCUSSION

In this section, the three, four and five element equivalent circuit models are first introduced from the literature. The circuit models are then simulated and the results are compared with those of the Finite Element Model shown in Fig. 1. The key focus is on comparing the impedance characteristics for both cases as well as the simulation times.

A. Three Element Equivalent Circuit Model:

In 1948, L. J. Chu presented a paper on the physical limitations of omni-directional antenna, where a simple three element circuit was introduced to represent an infinitesimally small dipole [4]. Later in 1993, T. G. Tang [6] investigated the three element circuit configuration of Chu, but suitable for a half-wavelength dipole antenna and employed a set of empirical equations to calculate the values of the circuit elements. The three element equivalent circuit model is shown in Fig. 2.

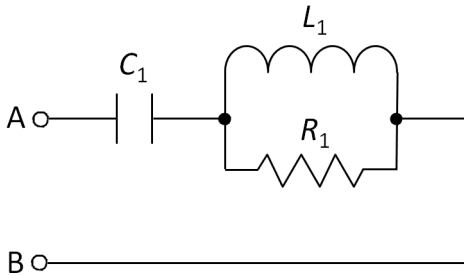

Fig. 2: Three element equivalent circuit model of a dipole [6].

The value of C_1 in Fig. 2 is calculated as a function of h and a using following equation [15]:

$$C_1 = \frac{\pi\epsilon_0 h}{\ln(h/a) - 1}, \quad (1)$$

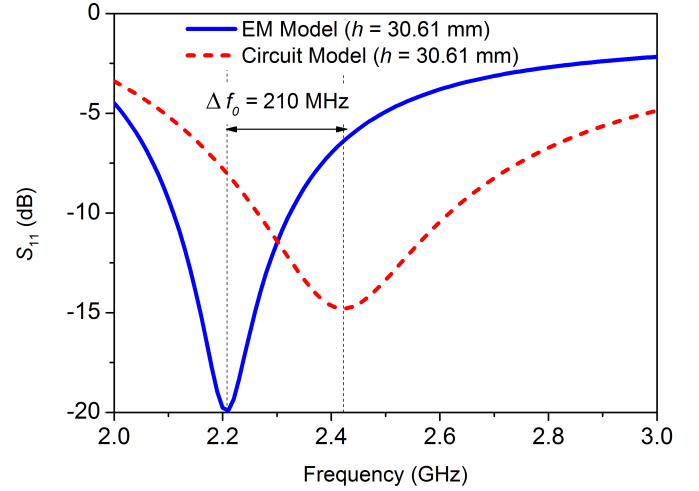

Fig. 3: Simulated return loss for FEM model and three element circuit model.

where ϵ_0 is the permittivity of free space (8.85×10^{-12} F/m). The value of L_1 depends on C_1 , the angular frequency ($\omega_0 = 2\pi f_0$) and the theoretical radiation resistance ($R_0 = 73 \Omega$) of a dipole antenna. R_1 depends on C_1 , L_1 and R_0 . L_1 and R_1 are calculated using the following equations [6]:

$$L_1 = \frac{1}{\omega_0^2 C_1} + C_1 R_0^2, \quad (2)$$

$$R_1 = \frac{L_1}{C_1 R_0}. \quad (3)$$

Using equations (1-3), for $h = 30.61$ mm and $a = 0.5$ mm, the calculated values of C_1 , L_1 and R_1 are 0.273 pF, 16.89 nH and 846.3 Ω respectively. The three element circuit configuration was simulated and the results were compared against the results of the full-wave simulation of the FEM model considering $h = 30.61$ mm, $a = 0.5$ mm and $g = 1$ mm. Fig. 3 shows the simulated return loss for the FEM model and the three element circuit model. It can be seen that the FEM model is resonant at 2.21 GHz and the circuit model is resonant at 2.42 GHz. The difference in the resonant frequency for the two models is 210 MHz. The dipole resonates at a frequency less than the specified frequency, $f_0 = 2.45$ GHz because the ends of the dipole contribute a finite capacitance which slightly reduces the resonant frequency. This phenomenon is called end-effect in dipoles [16].

Fig. 4 shows the simulated complex input impedance on the Smith chart from 2 to 3 GHz. Point A and B respectively, represents the input impedance for the FEM model and the three element circuit model at 2.45 GHz. The input impedance, Z_{in} at A = 101.20 + j69.27 Ω and at B = 72.97 - j0.44 Ω .

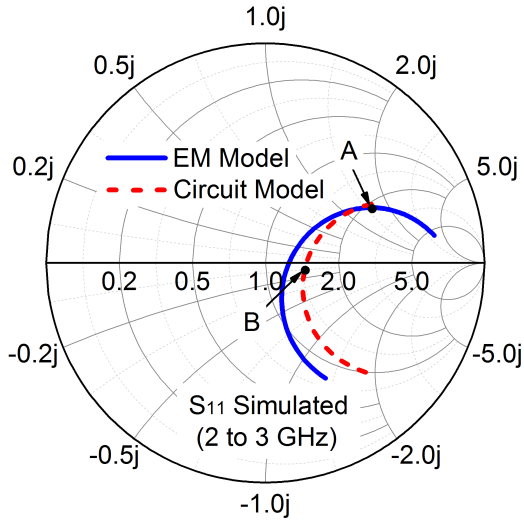

Fig. 4: Simulated Smith chart for FEM model and three element circuit model.

The difference in the input impedance from the FEM model and the circuit model is defined as the error. Thus, for the three element model, an error in the input impedance at 2.45 GHz is $28.23 + j69.7 \Omega$. Here, a large disagreement in Z_{in} for the EM and the circuit model can be seen. The specified resonant frequency, f_0 should be achieved by slightly reducing the size of the dipole [3]. However, in case of the three element model the specified frequency was not achievable even for a very large reduction in the dipole size. Also, for a very large change in h a negligible variation in Z_{in} was seen. Thus, a change in h does not cause the practically expected variation [3] in the resonant frequency and the input impedance. Therefore, it was concluded that the three element model is inaccurate for estimating the impedance characteristics of a practical linear wire dipole antenna at the specified resonant frequency. Thus, there is a need to introduce a new equivalent circuit model to improve accuracy in the input impedance and resonant frequency calculation of a dipole antenna.

B. Four Element Equivalent Circuit Model:

In 1981, G. W. Streable and L. W. Pearson proposed a four element model for a center-fed broadband dipole antenna [5]. Later in 1993, after performing an extensive empirical analysis, Tang proposed a new more accurate four element equivalent circuit model for a linear wire dipole antenna valid for $h \leq 0.3\lambda_0$ as shown in Fig. 5 [6]. Tang's four element model has a similar configuration to that of the three element model except for the added shunt capacitor C_3 . The capacitor C_3 provides more degree of freedom to attain the Z_{in} and f_0 , closer to those obtained from the FEM model.

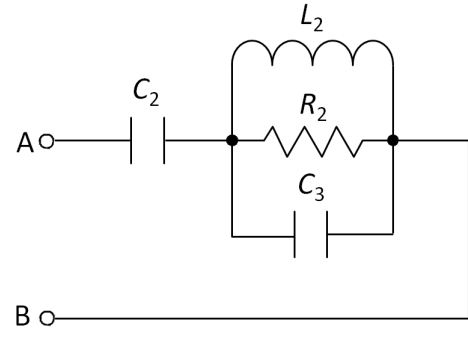

Fig. 5: Four element equivalent circuit model of a dipole [6].

The circuit elements C_2 , C_3 , L_2 and R_2 are given by [6]:

$$C_2 = \frac{12.0674 h}{\log(2h/a) - 0.7245} \text{ pF}. \quad (4)$$

$$C_3 = 2h \left\{ \frac{0.89075}{[\log(2h/a)]^{0.8006} - 0.861} - 0.02541 \right\} \text{ pF}. \quad (5)$$

$$L_2 = 0.2h \{ [1.4831 \log(2h/a)]^{1.012} - 0.6188 \} \mu\text{H}. \quad (6)$$

$$R_2 = 0.41288[\log(2h/a)]^2 + 7.40754(2h/a)^{-0.02389} - 7.27408 \text{ K}\Omega. \quad (7)$$

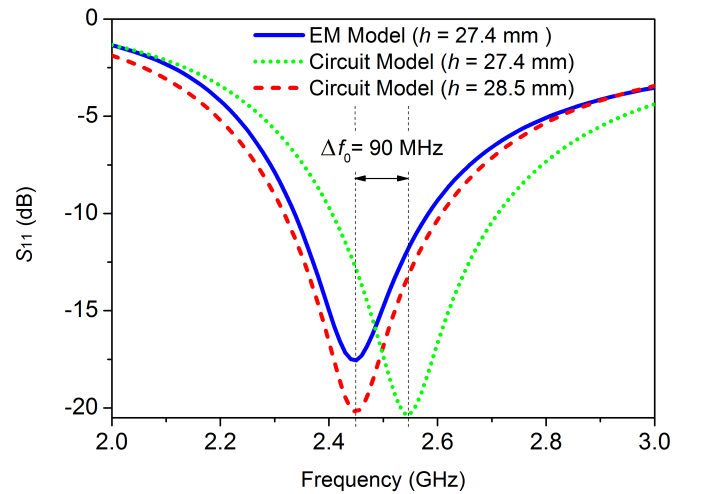

Fig. 6: Simulated return loss for FEM model and four element circuit model.

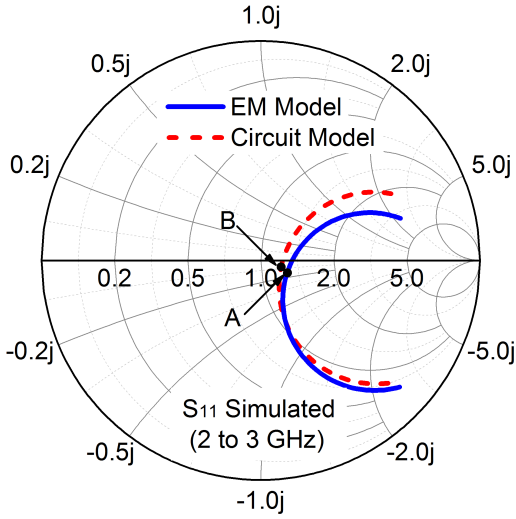

Fig. 7: Simulated Smith chart for FEM model and four element circuit model.

Fig. 6 shows the simulated return loss for the FEM model and the four element circuit model. For the FEM model the return loss is 17.5 dB and for the circuit model it is 20.23 dB. The four element model overestimates the return loss by 2.73 dB. Because of the end effect [16], the FEM model is resonant at 2.45 GHz for a slightly reduced length, $h = 27.4$ mm. However, for $h = 27.4$ mm the four element model is resonant at 2.54 GHz, which is 90 MHz higher than $f_0 = 2.45$ GHz. To achieve resonance at f_0 , the value of h was optimized to 28.5 mm for the circuit model. Employing equations (4-7), the value of circuit elements are calculated for $h = 28.5$ mm and $a = 0.5$ mm as $C_2 = 0.258$ pF, $L_2 = 14.07$ nH, $R_2 = 1.088$ K Ω and $C_3 = 0.0537$ pF. In Fig. 7 the Smith chart plot for 2 to 3 GHz is reported. Point A represents the input impedance for the FEM model and point B shows the input impedance for the four element model at 2.45 GHz. At A, $Z_{in} = 64.18 - j5.16 \Omega$ and at B, $Z_{in} = 60.43 - j2.62 \Omega$. Thus, with a difference of $3.75 - j2.54 \Omega$ in Z_{in} at 2.45 GHz, the four element model provides a useful estimate of the input impedance at the resonant frequency. To investigate if the accuracy in Z_{in} can further be improved, the five element equivalent circuit model is introduced.

C. Five Element Equivalent Circuit Model:

In 1997, Hamid [7] presented a five element equivalent circuit model for a linear wire dipole antenna using a graphical fitting method and is shown in Fig. 8. Further in 2012, Yi Liao [8, 9] presented a set of empirical equations to evaluate the values of the circuit elements. The five element model has a similar configuration to that of the Tang's four element model except for an added series inductor L_3 .

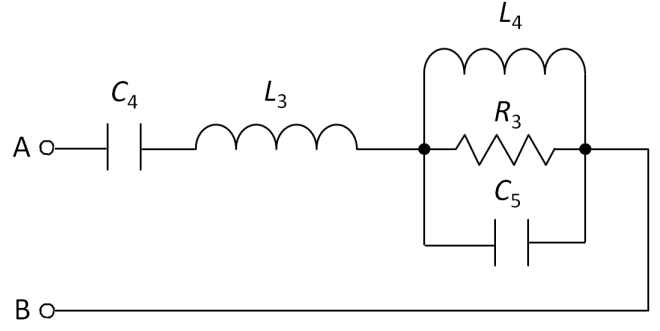

Fig. 8: Five element equivalent circuit model of a dipole [7].

In the empirical equations, variables ω_{01} and ω_{02} denote the first and second resonant angular frequencies, respectively at which reactance of the antenna ceases to exist and the resistance is R_0 . For a center-fed linear wire dipole antenna $R_0 = 73 \Omega$. The values of ω_{01} and ω_{02} are determined using equations (13) and (14), provided $20 \leq h/a \leq 2000$. L_3 is chosen to resonate with C_4 at ω_{02} and L_4 is selected to resonate with C_5 at ω_{02} also. The value of C_4 can be determined using equation (1). The value of the circuit elements L_3 , C_5 , L_4 and R_3 are calculated using following equations [8]:

$$L_3 = \frac{1}{\omega_{02}^2 C_4}, \quad (8)$$

$$C_5 = \frac{A}{R_0^2 + A^2} \left(\frac{\omega_{01}}{\omega_{01}^2 - \omega_{02}^2} \right), \quad (9)$$

$$L_4 = \frac{R_0^2 + A^2}{A} \left(\frac{\omega_{01}}{\omega_{02}^2} - \frac{1}{\omega_{01}} \right), \quad (10)$$

$$R_3 = \frac{R_0^2 + A^2}{R_0}. \quad (11)$$

where,

$$A = \omega_{01} L_4 - \frac{1}{\omega_{01} C_4}, \quad (12)$$

$$\omega_{01} = \frac{2\pi c}{4h} \left[806.1 - 0.03043(h/a) + 1.061 \times 10^{-5}(h/a)^2 - 2.09 \times 10^{-9}(h/a)^3 + 51.59 \ln(h/a) - 8.186(\ln(h/a))^2 + 0.5502(\ln(h/a))^3 \right] \times 10^{-3}, \quad (13)$$

$$\omega_{02} = \frac{2\pi c}{2h} \left[1108 + 0.1039(h/a) - 1.808 \times 10^{-5}(h/a)^2 \right. \\ \left. + 2.203 \times 10^{-9}(h/a)^3 - 215.5 \ln(h/a) \right. \\ \left. + 51.59(\ln(h/a))^2 - 3.85(\ln(h/a))^3 \right] \times 10^{-3}. \quad (14)$$

In Fig. 9 the return loss for the FEM model and the five element circuit model is reported. For the FEM model the return loss is 17.5 dB and for the circuit model it is 14.97 dB. The five element model underestimates the return loss by 2.53 dB. The FEM model is resonant at 2.45 GHz for $h = 27.4$ mm. However, for $h = 27.4$ mm the five element model resonates at 2.47 GHz, which is 20 MHz higher than the specified frequency, f_0 . The circuit model is resonant at $f_0 = 2.45$ GHz for $h = 27.7$ mm. Using equations (1) and (8-14), the values of all the circuit elements are calculated for $h = 27.7$ mm and $a = 0.5$ mm and the resulting values are $C_4 = 0.255$ pF, $L_3 = 4.897$ nH, $L_4 = 9.198$ nH, $R_3 = 493.24$ Ω and $C_5 = 0.136$ pF.

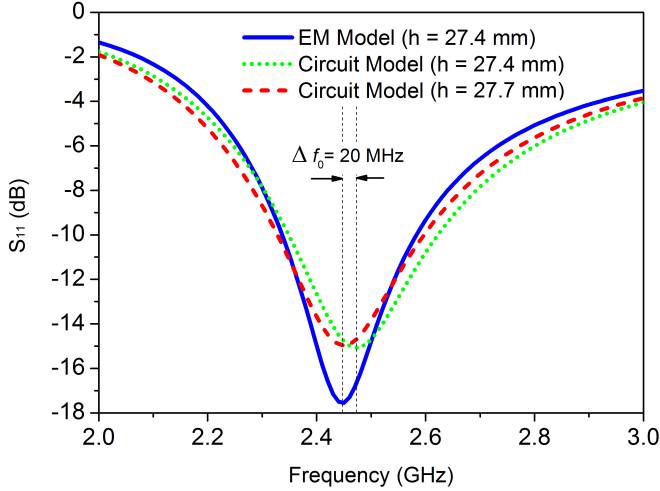

Fig. 9: Simulated return loss for FEM model and five element circuit model.

Fig. 10 shows the simulated input impedance from 2 to 3 GHz. Point A depicts the input impedance for the FEM model and point B represents the input impedance for the five element model at 2.45 GHz. The input impedance at 2.45 GHz for the FEM model is $64.18 - j5.16$ Ω and for the circuit model it is $70.39 - j6.84$ Ω . Thus, with a difference of $-6.21 + j1.68$ Ω , in Z_{in} at 2.45 GHz, the five element circuit model demonstrates a good agreement with the FEM model. Also, it was found that on a computer with an 8 GB RAM, 2.66 GHz processor and 64-bit operating system, the

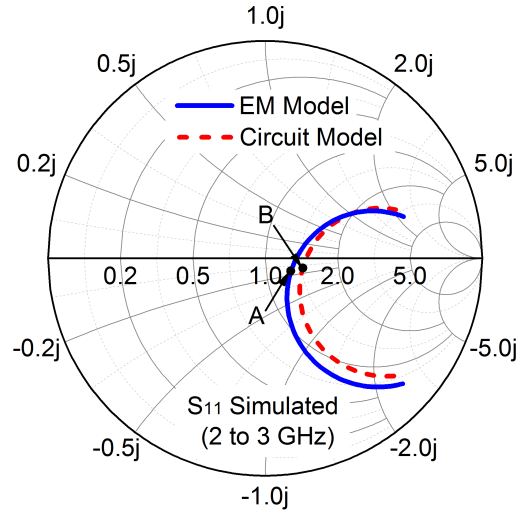

Fig. 10: Simulated Smith chart for FEM model and five element circuit model.

simulation time for the FEM model was 1.24 minutes and for the circuit model it was merely 0.01 seconds. Thus, the circuit model estimates the impedance characteristics of a linear wire dipole antenna at significantly faster speed than the FEM model.

IV. CONCLUSION

In this work, three types of dipole antenna equivalent circuit models from the literature have been investigated. All the equivalent circuit models have been compared against a full-wave FEM model of the antenna. It was found that the three element model is inaccurate because, for a large change in the dipole half-length h , a negligibly small variation in Z_{in} and resonant frequency was observed. Compared to the FEM model, the four element model estimates the input impedance at 2.45 GHz with an error of $3.75 - j2.54$ Ω . For the five element model an error of $-6.21 + j1.68$ Ω , in Z_{in} at 2.45 GHz was observed. The results show that at the specified resonant frequency, both four and five element equivalent circuit models render the value of the input impedance close to the FEM model. In addition, the simplicity of the circuit models enable a solution to be computed in a fraction of a second compared to over a minute for the FEM model or a factor of 7,440 times faster for the five element case.

ACKNOWLEDGMENT

This publication has emanated from research supported by a research grant from Science Foundation Ireland (SFI) and is co-funded under the European Regional Development Fund under Grant Number 13/RC/2077.

REFERENCES

- [1] D. Feng, C. Jiang, G. Lim, L. J. Cimini, G. Feng and G. Y. Li, "A Survey of Energy-Efficient Wireless Communications," *IEEE Communications Surveys & Tutorials*, vol. 15, no. 1, pp. 167-178, 2013.
- [2] H. Schantz, *The art and science of ultrawideband antennas*, Artech House, Norwood, MA, 2005.
- [3] C.A. Balanis, *Antenna theory: Analysis and design*, 2nd ed., Wiley, Hoboken, NJ, 2005.
- [4] L. J. Chu, "Physical limitations of omni-directional antennas," *J. Appl. Phys.*, vol. 19, pp. 1163-1175, Dec. 1948.
- [5] G. W. Stuble and L. W. Pearson, "A numerical study on realizable broad-band and equivalent admittances for dipole and loop antennas," *IEEE Trans. Antennas Propag.*, vol. AP-29, no. 5, pp. 707-717, Sep. 1981.
- [6] T. G. Tang, Q. M. Tieng and M. W. Gunn, "Equivalent circuit of a dipole antenna using frequency-independent lumped elements," *IEEE Trans. Antennas and Propag.*, vol. 41, no. 1, pp. 100-103, Jan. 1993.
- [7] M. Hamid and R. Hamid, "Equivalent circuit of dipole antenna of arbitrary length," *IEEE Trans. Antennas and Propag.*, vol. 45, no. 11, pp. 1695-1696, Nov. 1997.
- [8] Yi Liao, T.H. Hubing and D. Su, "Equivalent Circuit With Frequency-Independent Lumped Elements for Coated Wire Antennas," *IEEE Trans. Antennas and Propag.*, vol. 60, no. 11, pp. 5419-5423, Nov. 2012.
- [9] Yi Liao, T.H. Hubing and D. Su, "Equivalent Circuit for Dipole Antennas in a Lossy Medium," *IEEE Trans. Antennas and Propag.*, vol. 60, no. 8, pp. 3950-3953, Aug. 2012.
- [10] J. Wang, E. Schluntz, B. Otis and T. Deyle, "A New Vision for Smart Objects and the Internet of Things: Mobile Robots and Long-Range UHF RFID Sensor Tags," *CoRR*, 2015.
- [11] I. Hwang, D. Kwon, D. Lee, J. Yu and W. Lee, "EM/light Hybrid Energy Harvesting with Directional Dipole Antenna for IoT Sensor," *IEEE International Symposium on Antennas and Propagation & USNC/URSI National Radio Science Meeting*, pp. 1292-1293, July, 2015.
- [12] J. M. Rigelsford, H. Hussein, R. J. Alkudhairi, "Active antenna with switchable beams for wireless sensor networks and IoT," *International Conference on Antenna Theory and Techniques*, pp. 228-231, may, 2017.
- [13] W. Honglei, Y. Kunde and Z. Kun, "Performance of Dipole Antenna in Underwater Wireless Sensor Communication," *IEEE Sensors Journal*, vol. 15, no. 11, pp. 6354-6359, Nov. 2015.
- [14] K. K. A. John, J. Abraham and T. Mathew, "Dual band dipole antenna for RFID/WSN applications," *International Conference on Electronics and Communication Systems (ICECS)*, pp. 1-3, 2014.
- [15] S. A. Schelkunoff and H. T. Friis, *Antennas: Theory and Practice*, New York: Wiley, 1952, p.306. New York: Wiley, pp. 306, 1952.
- [16] M. I. Ahmad et. al, "Design and Analysis of Cross Cage Dipole Antenna," *IEEE International Conference on Advances in Space Technologies*, pp. 75-80, Sept. 2006.
- [17] NI AWR Design Environment. NI, July. 2017 [Online]. Available: <http://http://www.awrcorp.com/>
- [18] ANSYS HFSS. ANSYS, July. 2017 [Online]. Available: <http://www.ansys.com/products/electronics/ansys-hfss>