

Title	A survey of reliability assessment techniques for modern distribution networks
Authors	Escalera, Alberto;Hayes, Barry P.;Prodanovic, Milan
Publication date	2018-04-14
Original Citation	Escalera, A., Hayes, B. and Prodanović, M. (2018) 'A survey of reliability assessment techniques for modern distribution networks', Renewable and Sustainable Energy Reviews, 91, pp. 344-357. doi: 10.1016/j.rser.2018.02.031
Type of publication	Article (peer-reviewed)
Link to publisher's version	<a href="http://www.sciencedirect.com/science/article/pii/S1364032118300650">http://www.sciencedirect.com/science/article/pii/S1364032118300650</a> - 10.1016/j.rser.2018.02.031
Rights	© 2018 Elsevier Ltd. All rights reserved. This manuscript version is made available under the CC-BY-NC-ND 4.0 license - <a href="http://creativecommons.org/licenses/by-nc-nd/4.0/">http://creativecommons.org/licenses/by-nc-nd/4.0/</a>
Download date	2024-06-23 04:09:50
Item downloaded from	<a href="https://hdl.handle.net/10468/8117">https://hdl.handle.net/10468/8117</a>



# UCC

**University College Cork, Ireland**  
 Coláiste na hOllscoile Corcaigh

# A Survey of Reliability Assessment Techniques for Modern Distribution Networks

Alberto Escalera<sup>a,c</sup>, Barry Hayes<sup>b</sup>, Milan Prodanović<sup>a</sup>

<sup>a</sup>*Electrical Systems Unit, IMDEA Energy Institute, Avda. Ramón de la Sagra 23, Móstoles-28935, Madrid, Spain*

<sup>b</sup>*NUI Galway, University Road, Galway, Ireland*

<sup>c</sup>*Department of Electrical Engineering, Universidad Carlos III de Madrid, Avda. Universidad 30, 28911-Leganés, Madrid, Spain*

---

## Abstract

Reliability assessment tools are of crucial importance for planning and modernisation of distribution power systems. In recent years there has been an increased deployment of renewable energy, distributed generation, energy storage, electric vehicle, protection device automation and demand response schemes in the distribution networks. All these technologies contribute in their own way to the network reliability. The objective of this paper is to provide a critical survey of the reliability assessment techniques used for the evaluation of distribution networks, emphasising the importance of an increased penetration of distributed energy resources and a more widespread application of the control, protection and communication technologies. A detailed analysis and a comparison between different techniques and models used for the reliability assessment will be provided for each technology along with the guidelines for their application. A case study will be used to demonstrate the properties and the modelling procedure of the reliability assessment tools for modern distribution networks.

*Keywords:* Reliability Assessment; Distribution Networks; Distributed Generation; Renewable Energy; Energy Storage; Protection Devices Automation; Microgrids; Demand Response.

---

*Email addresses:* [alberto.escalera@imdea.org](mailto:alberto.escalera@imdea.org) (Alberto Escalera), [barry.hayes@nuigalway.ie](mailto:barry.hayes@nuigalway.ie) (Barry Hayes), [milan.prodanovic@imdea.org](mailto:milan.prodanovic@imdea.org) (Milan Prodanović)

## 1. Introduction

Reliability of power supplied to a customer can be measured by the impact interruptions cause to customers and distribution companies [1] under network fault conditions. Consequently, specific reliability levels are set by the regulators and penalties introduced for distribution network operators failing to comply with them. Also an adequate reliability level during the distribution network planning stage have to be considered.

Traditional solutions to providing an adequate level of reliability in distribution networks are the following: meshed grids (components in parallel, alternative feeders to restore the supply, etc.), improved maintenance of the assets, application of more reliable components and installation of additional protection devices. The evolution of distribution networks towards Smart Grids and more sustainable energy systems creates a new set of opportunities for further improvement of the reliability of supply [2, 3].

For example, during a fault in the distribution network an aggregation of both conventional and renewable DG can provide sufficient power to supply those interrupted areas that cannot be otherwise supplied by the primary substation.

Energy storage technologies can be used to mitigate the fluctuations of renewable generation and extend their contribution to the supply restoration. Automation of the protection devices can be used to reduce the time response necessary for the network reconfigurations in presence of fault conditions. Also, the application of Demand Response (DR) techniques can help decrease the peak demand selectively and preserve the security of supply under emergency conditions.

The impact of all these technologies on the reliability of supply has to be properly addressed in order to support planning decisions in distribution networks [4]. Therefore, the techniques commonly used to assess the impact of different network technologies on the reliability of supply are of a particular interest. The critical review of techniques will help identify the most suitable ones for any given network scenario and, in this way, help guarantee the reliability of future distribution networks.

Several publications have addressed the state of the art in reliability assessment techniques applied to distribution networks. The most relevant probabilistic methods applied to reliability evaluation of power systems from 1964 to 1999 were presented in [5, 6, 7, 8, 9, 10] and some of them addressed distribution networks. EPRI white paper in [11] presented definitions, con-

cepts, practices and regulatory issues with respect to reliability in distribution networks and a dedicated chapter addressed the principal techniques and the software used. In year 2000, a review of the reliability evaluation techniques applied to distribution networks was published in [12]. In this paper it was explained how the techniques can be used (or adapted) to suit the competitive nature of modern power systems along with the additional modelling requirements for generation resources in distribution networks. In [13], the reliability assessment techniques for distribution networks were classified by methodology, reliability indices used and inclusion of Distributed Generation (DG). The models and algorithms applied to reliability evaluation of power systems with wind generation were found in [14]. A review of the models used for the evaluation of the impact of renewable energy sources on the reliability of distribution networks was included in [15]. Although some of those reviews assessed the reliability impacts of conventional and renewable DG on distribution networks, a critical and complete comparison of the applied methodologies has not been found in the existing scientific literature. Moreover, techniques for reliability assessment of modern distribution networks with energy storage, microgrids, electric vehicle, DR and protection devices have not been adequately addressed.

This paper provides a literature review of the most relevant techniques used for reliability assessment of modern distribution networks. The principles and the methodologies proposed for the reliability evaluation of the above-mentioned technologies will be firstly introduced and then critically reviewed. The properties and shortcomings of the reliability assessment tools and the technology models applied will be discussed. A case study will be presented to illustrate how the discussion of the methodologies in the survey and the comparison of the results can be applied to model the most appropriate techniques for reliability assessment.

The objectives of the survey are: a) to provide a state-of-the-art in the topic to researchers and practitioners in the field, b) support in modelling the appropriate reliability assessment techniques for modern distribution networks with specific requirements and technologies c) identify opportunities for future research in the field.

The paper is organized as follows: Section 2 describes how the new technologies in Smart Grids can further improve the reliability of supply, Section 3 briefly introduces the methodology for the reliability assessment of conventional distribution networks, Section 4 provides a critical analysis of the techniques proposed for the reliability evaluation of DG, energy storage,

microgrids, electric vehicle, DR, protection devices automation and communication technologies. In Section 5 a case study is used to illustrate how the survey can be applied to model the appropriate tools for reliability assessment. Finally, concluding remarks including the main findings and future research are summarized in Section 6.

## **2. Reliability in Modern Distribution Networks**

The development of the Smart Grids implicitly creates new opportunities for improving reliability of modern distribution networks [3] and are described in this section.

### **2.1. Distributed Generation**

Installed Distributed Generation (DG) capacity can be used to improve reliability of distribution systems [16]. Under fault conditions in a distribution network, the power supply to some areas of the network can be interrupted. The DG installed in these areas can be used then to restore the interrupted supply and improve the reliability.

DGs can be found operating in two modes: islanded mode and grid-connected mode [17] (see Figure 1). Both modes can be used to improve the reliability of supply. The islanded mode refers to the areas isolated from the primary substation under fault conditions. In this case, the DGs located within isolated areas are used to provide energy that is not supplied by the primary substation. The grid-connected refers to the areas of the network equipped with Normally-Open Points (NOPs) that have a limited capacity to transfer power from adjacent feeders. In such a case, the DG can be used to increase that transfer capacity as shown Figure 1.

### **2.2. Energy Storage**

A significant part of the DG will be from variable renewable sources exposed to fluctuations and energy storage systems are installed in networks mainly to support their operation. Capability of variable DG to restore the interrupted supply is extended by using energy storage as Figure 2 shows. Consequently, energy storage can be used to improve the reliability of distribution networks.

DG and energy storage location, capacity, availability and operation are the principal factors that affect the network reliability. The impact of these factors is necessary to be evaluated during the planning stage.

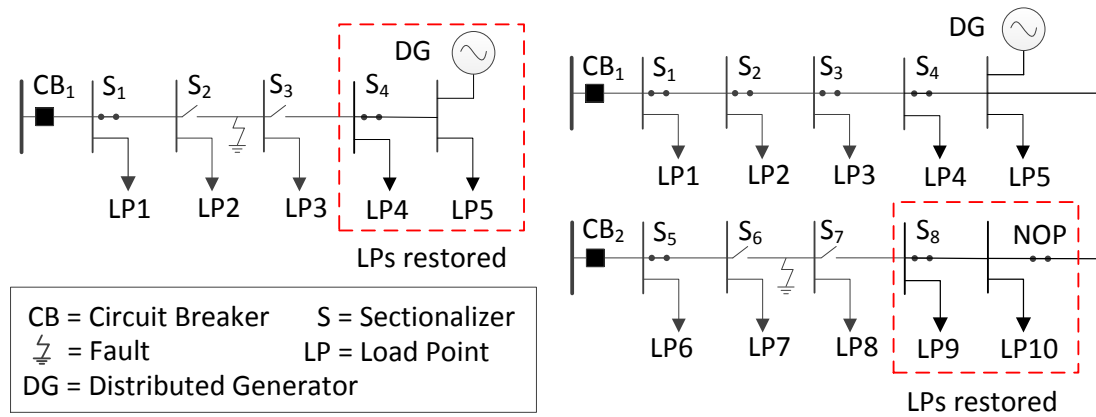

Figure 1: DG operating modes for improvement of reliability of supply: islanded mode (left) and grid-connected mode (right)

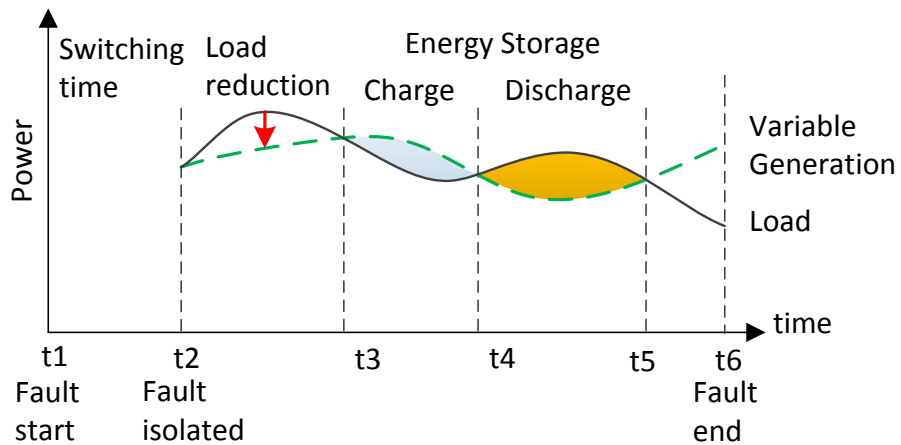

Figure 2: Contribution of energy storage and demand response to enhance the reliability of supply

### **2.3. Demand Response**

One of the roles of Demand Response (DR) is to reduce the load under fault conditions by disconnecting or shifting less critical loads. The load reduction allows DG to restore the supply in both operating modes of the distribution network, islanded and grid-connected (see Figure 2).

### **2.4. Electric Vehicles**

Electric Vehicles introduce several options for reliability improvement: a) Demand reduction under fault conditions (similar to demand response); b) Offer energy stored during fault conditions (similar to energy storage), both in vehicle-to-grid or vehicle-to-home modes.

### **2.5. Automation of protection devices**

The number and the duration of interruptions can be significantly reduced by applying advanced control of protection devices. Identifying fault locations, applying fault isolation and remotely controlling restoration process are only some examples of possible improvements affecting the reliability and continuity of supply. A dynamic and selective control of customers restored (or not restored) during faults is also an option.

### **2.6. Microgrids**

In the case of a fault condition intentional islanding of some parts of a distribution network represents an option to improve the continuity of supply. Once islanded the network operates as a microgrid and the Distributed Energy Resources (DG, energy storage, DR...) can be used to supply the local demand within the microgrid.

## **3. Reliability Evaluation in Conventional Distribution Networks**

The aim of reliability assessment techniques is to estimate the impact of interruptions on customers. Figure 3 shows an overview of the input data required and the output data calculated by the techniques used for reliability assessment of conventional distribution networks. Statistical data of failures in network components (failure rate and repair time) are used by the techniques in order to determine the reliability indices [18], i.e, the metrics used to quantify the impact of interruptions. The reliability indices for individual customers or an area of a network are then calculated along

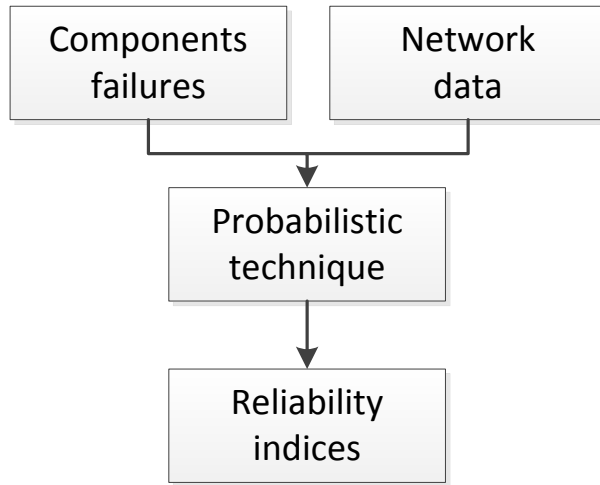

Figure 3: Inputs and outputs in a traditional technique for reliability assessment

with the indices that estimate the economic impact of the interruptions. These indices provide useful information for the planning of the network.

Reliability assessment techniques are classified in two approaches: analytical and Monte Carlo simulation [1]. Analytical techniques use mathematical expressions to calculate average values of the reliability indices. On the contrary, Monte Carlo simulation performs a sample of failures in components of the network to compute the probability distribution of the reliability indices. In addition to more accurate reliability indices, Monte Carlo approach has the advantage of performing a stochastic evaluation of the failures in the network. In contrast, computational times are longer than analytical approach. According to this, the approach to be used depends on the specific requirements of the analysis [10].

Evaluation of failures in the network components requires from probabilistic models. Traditionally two state (up and down) Markov models are used and average values of load are normally assumed.

A typical methodology to assess the reliability includes the following steps [19]: failure in the network is simulated, protection devices operated, affected load points identified, restoration of supply techniques applied and reliability indices computed. The performance of the protection devices (breakers, manual switches, fuses, reclosers, automatic sectionalizers) and the reconfiguration schemes are also included in the methodologies for reliability assessment.



With the development of Smart Grids, the impact of the new technologies on the reliability of distribution networks needs to be assessed by applying new methods.

## 4. Reliability Evaluation Techniques for Modern Distribution Networks

This section provides a survey and discusses the most relevant techniques used for the reliability evaluation of modern distribution networks. It is assumed such networks consist of conventional and renewable DG, energy storage, microgrids, electric vehicles, demand response actions, automation of protection devices and information and communications.

### 4.1. Distributed Generation

The techniques for reliability assessment need to be capable of quantifying the contribution of DG on network reliability by assessing the capacity of DG to restore the interrupted supply. The following DG properties affecting the restoration capacity need to be included in the reliability assessment:

- availability of the DG units exposed to failures
- operating mode of the DG (islanded or grid-connected)
- energy source (dispatchable or non-dispatchable)

#### 4.1.1. Availability of the DG units

The DG units are exposed to failures that limit their available capacity to restore the supply. DG reliability models need to be capable of evaluating the DG availability to restore the supply under fault conditions. Because of the stochastic nature of the failure of DG unit, probabilistic models are proposed. Markov models are typically used to model the failures of components in distribution networks. Several variants of Markov models can be used [1], although a simple solution is to use the two state Markov model as shown in Figure 4. It is defined by up and down states and the transitions between them. Another option is to include additional derated states in the model that represent different levels of DG unit generation power as depicted in Figure 4.

In the case of dispatchable generation, the generation power of each state in the Markov model is known and constant. However, the generation for

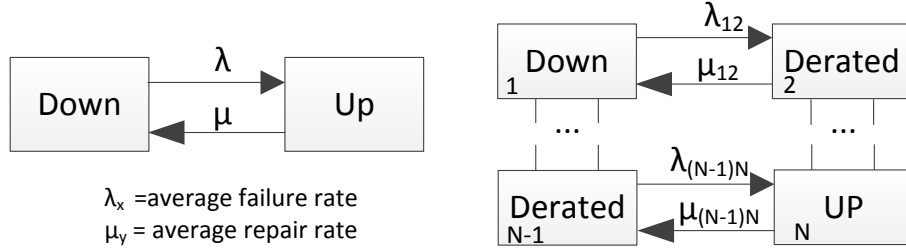

Figure 4: Two states Markov model (left) and example of N-states Markov model with derated states(right)

non-dispatchable DG like wind and solar is conditioned by the availability of the variable resources and needs to be determined. A review of the reliability models for renewable DG and the definition of the available resource is given in [15]. Nevertheless, the adequateness of this model is conditioned by the technique used and the operating mode of DG. A more detailed discussion of the models used to assess the variability of renewable generation is given in the following sections.

An additional consideration is that the integration of renewable generation depends on the application of power electronics technology. The reliability of power electronics devices has to be included in the reliability assessment. The reliability models for inverters used in PV generators are described in [20] and [21].

#### 4.1.2. Islanded operation

At present the regulation does not permit the intentional islanding operation in distribution networks in most countries. One of the limitations is the requirement for appropriate control, protection and communication technologies that guarantees the successful operation of DG in islanded mode. Developments in the field make the islanding operation promising when it comes to improvement of distribution network reliability. Consequently, numerous techniques have been proposed in recent years related to reliability assessment of distribution networks in islanded operation. These techniques model the principles of islanded operation affecting the reliability, like the actuation of protection devices, adequacy assessment of load and generation, modelling of generation and load and other features.

*Configuration time of the isolated area:*

Before an isolated area switches to the islanded mode some time is required for the fault to be isolated and alternative generation sources connected. This time is defined by the switching operation of the protection devices and the start of the DGs involved. As Figure 2 shows, it involves an interruption of supply to the customers and its impact on reliability has to be captured and quantified by the reliability assessment techniques. Therefore, the protection devices and the DGs involved in the islanding process are identified and the procedure for the island forming simulated.

In order to quantify the impact of the protection devices operation in islanded operation, a set of analytical expressions are presented in [22, 23]. The expressions assess a large number of operational cases of protection devices. Nevertheless, a more accurate evaluation is proposed in [24]. In this paper there is a differentiation between the opening and closing times of all sectionalizers involved in the restoration process.

The definition of the starting time of the DG units depends on the generator technology and its operating mode at the moment of the fault. The earliest techniques proposed to assess the reliability impact of dispatchable DG [25, 26] already included equations for quantifying the effect of the starting time in the interruption duration. In general, most reliability assessment techniques proposed consider the DG starting times, however, what is not commonly considered in the evaluation of the starting times of the DG units is their operation at the moment of the fault. This impact was evaluated in [27] by identifying the probability the generators will be in operation or in standby mode at the moment when the fault occurs.

*Adequacy assessment of the isolated area:*

Once the isolated area has been configured for the islanded operation, the adequacy of generation and load in the island is evaluated. It is defined as the capacity of the DG units to supply the interrupted demand during the emergency conditions. This is a fundamental requirement for all methodologies used in reliability assessment of networks that considers restoration by DG in islanded operation.

Based on the adequacy assessment and the capacities of the distribution network, several criteria are used to restore the supply in an island by using DG. One option is to determine what is the interrupted supply that needs to be restored over the adequacy assessment-time. Consequently, a generation shortage at any moment of the adequacy evaluation results in no load being restored. A second option is to restore the supply in those time inter-

vals of the adequacy-assessment time that guarantee the non-occurrence of repetitive interruptions in restored customers [28, 29]. An alternative option for increasing the load restoration is the application of load-shedding actions under conditions of limited generation in the island [22, 30, 24]. A fundamental premise in all these restoration strategies is that there is no additional number of interruptions to the customers. An extension to the restoration strategies can be done regarding the minimization of the interrupted load during the fault.

DG unit faults are represented in the adequacy assessment by their reliability models. The models used for generation and load represent another important factor in the adequacy assessment and will be described in the following section.

*Generation and load models:*

For dispatchable DG, a constant power of generation is assigned to the states in the reliability model [25, 31, 32, 27]. However, the existing environmental and market principles suggest that in future a significant part of DG units integrated will be from renewable intermittent sources such as solar and wind. These variable resources reduce the ability of generation to meet the demand of an island and, therefore, affect the reliability. In addition, the demand is also variable (uncertain) and the restoration of supply is influenced by the chronological dependence of variable generation and load. Hence, existing techniques for reliability evaluation need to be extended to address this variability effect. To overcome this challenge, Monte Carlo simulation approach is frequently used [33, 34, 35, 36, 37, 38] because it provides more flexibility and accuracy than analytical approaches for modelling the variability.

Although Monte Carlo simulation is the most commonly used approach to assess the reliability impact of non-dispatchable DG accurately and provides probability distribution of the reliability indices, its high computation times explain the interest in looking for alternative analytical techniques. Because analytical techniques do not consider the stochastic behaviour of the fault occurrence, they require more attention in modelling the variability and time-dependency of renewable generation and load [39]. Despite of the specific probabilistic models of generation and load required for the analytical approach, more attempts and novel solutions have been reported in recent years as shown in Table 1. This table summarizes and compares both analytical and Monte Carlo simulation techniques.

In [33, 34, 35] the average load of the isolated area during the fault duration is determined, while a 3 states Markov model (up,down and derated) that combines the availabilities of the generator and the renewable resource is used for wind DG. Using these models of load and generation, the restoration is applied if the minimum power of the renewable generation is higher than the demand. Nevertheless, the fluctuations of the load in the adequacy assessment are disregarded. An alternative that considers the load variability is based on probabilistic tables that describe a set of power levels and their respective probabilities (capacity probabilistic outage table), both for demand and variable generation [37, 40, 22, 41]. For each power level of generation and load in the probabilistic tables, the adequacy is evaluated in order to determine the restoration capacity of DG. Simulation techniques sample the level of load and generations stochastically and the analytical techniques calculate the probability of adequacy. The main inconvenience of the probabilistic tables is the use of a discrete number of power levels and the impossibility of considering the time dependent fluctuations of load and generation during the fault duration. It is demonstrated that neglecting the load and generation fluctuations leads to a strong overestimation of the DG capacity to meet the load of the island [29]. For a more accurate reliability evaluation, new developments are sought that take into consideration the time-dependent fluctuations of load and generation during the repair time.

Hourly profiles of load and generation can be considered in Monte Carlo simulation techniques [36, 38], although the adequacy assessment may demand more computational resources in the simulation process. In the case of analytical techniques, several options are available. A set of power levels of generation and load in a typical day of the year are used in [42].

The approaches that use hourly models of variable generation and load represent a more effective solution even though they increase the complexity of the analytical formulation. Instead of using a whole year of load and variable generation data, the hourly data of the year are divided into a set of representative periods, e.g., typical day of each season in a year. In [43] the hourly representative generation and load models in the island were established to compute analytically the reliability indices. In [28] the hourly probability of successful restoration by DG was calculated from the representative time segments of generation and load in the island. The accuracy of these hourly-based methods was verified by using the results from the Monte Carlo simulation, in spite of not modelling the full variability of load and generation as yearly profiles do.

Markov models are also a feasible alternative to evaluate the fluctuations of renewable generation and load during the islanded operation [29], although the complexity of the model can increase significantly with the number of power levels and the transitions between them. Another alternative to quantify the variations of load and generation consists of obtaining a set of scenarios from historical data for load and generation and use them as input data in the reliability assessment techniques [24]. An important factor to be assessed is the selection of scenarios that guarantees that reliability indices are accurate enough.

Table 1: Comparison of techniques for reliability assessment of DG in islanded operation

Ref.	DG type <sup>a</sup>	Technique	Generation Model	Load Model	Restoration strategy <sup>b</sup>
[25], [26], [27]	D	Analytical	-	-	(1)
[33], [34], [35]	D, ND	SMCS	3 states Markov model	Average	(1)
[37]	D, ND	SMCS, Non-SMCS	Probabilistic outage table		(1)
[36], [38]	D, ND	SMCS	Hourly profiles of a year		(2)/(1)
[42]	D, ND	Analytical	Levels of a typical day		(1)
[40], [22], [41]	D, ND	Analytical	Probabilistic outage table		(1)/(2)/(1)
[43], [28], [24], [29]	D, ND	Analytical	Representative segments of a year		(1)/(2)/(1)

<sup>a</sup> D=Dispatchable; ND=Non-dispatchable

<sup>b</sup> (1) All load in the island has to be restored; (2) Load shedding; (3) Non repetitive interruptions

*Other effects in islanded operation:*

It is not a common practice to evaluate network constraints in the adequacy assessment because it is typically assumed that the appropriate network design during the planning stage was applied. Yet a massive integration of renewable DG can contribute to violation of operational limits. A realistic adequacy assessment should include the evaluation of the network constraints and power-flow based techniques. Some of the existing techniques have power flow calculations integrated in their reliability assessment, both analytical [26] and simulation [36, 44]. Considering network constraints in simulation techniques implies a large number of power flows to be calculated that increases

the computation time significantly. Alternative simplified power flow formulations were recommended in order to decrease the computational time [45].

Based on the information provided by power flow calculations, corrective actions are applied in case of a network constraint violation. Load disconnection or generation curtailment are typical solutions to preserve the operational limits in reliability assessment techniques. An alternative to be investigated is the modelling of corrective actions based on Active Network Management schemes [46] in smart distribution systems.

Another aspect not considered in previous publication addressing the adequacy assessment process is the dynamic effect of frequency and voltage deviations. It affects the feasibility of the islanded operation and their inclusion in the reliability assessment guarantees more accurate results. A methodology to include the islanding dynamics effects in the reliability evaluation of active distribution networks is proposed in [47].

Moreover, the distribution networks with integrated DG can operate under a wide range of operating conditions. Consequently, the settings of the protection devices are exposed to numerous changes and an incorrect actions may occur. Consequently, the reliability can be affected and it is recommendable to consider these phenomena in the techniques for reliability assessment.

#### *4.1.3. Grid-connected operation*

In grid-connected operating mode, DG improves the reliability of distribution systems by reducing the equipment loading and by enabling load transfers from adjacent feeders experiencing outages [16]. In order to estimate the reliability impact it is necessary to quantify the transfer capacity between feeders in presence of DG.

There has been less research results round for the reliability evaluation of the grid-connected mode than for the islanded mode, probably because the restoration from alternative feeders in distribution networks is designed not to experience transfer restrictions even without DG presence. However, the power transfer restrictions can be applied in order to avoid violation of network constraints [48, 49], especially with the increase of the demand. Hence, some publications perform power flow calculations to calculate the transfer capacity of distribution networks with DG [50, 44] as Table 2 shows. It is assumed the load transfer is accomplished if the network constraints are not violated.

The techniques based on power flow calculations require more computational resources and their application in simulation techniques may be unac-

ceptable or excessively long. A simplified procedure to determine the transfer capacity without power flow calculations represents a computationally efficient alternative even though the accuracy can be compromised. In [51] an analytical procedure is used to calculate the transfer capacity according to a set of load levels in the network (low, medium and high). Then, the analytical procedure is integrated inside of Monte Carlo simulation to reduce the computational time. Other non power-flow based technique [52] for reliability assessment calculates the available supply capacity of DG in grid-connected mode from the joint probability of demand and generation during the outage. A set of levels of generation, load and transitions between them are used to quantify the joint probability. However, the time dependent fluctuations of load and generation during the outage are not included by the joint probability method. An alternative to overcome this limitation is to use a reduced set of representative scenarios for load and generation. The transfer capacity can be then deduced from these scenarios and the DG contribution on the reliability assessed.

Table 2: Comparison of techniques for reliability assessment of DG in grid-connected operation

Ref.	Technique	Network constraints considered	Power flow	Transfer capacity calculation
[50], [44]	Analytical	Loading and voltage	Yes	Transfer produced if DG alleviates the network constraints violated
[51]	MCS + Analytical	Loading	No	Transfer capacity determined from the load level (high, medium, low)
[52]	Analytical	Loading	No	Lines capacity and joint probability of DG and load

## 4.2. Energy Storage Systems

In addition to their primary roles like load shifting, congestion alleviation, frequency control, voltage control and electricity trading, energy storage can also contribute to improve the reliability of distribution networks. Under fault conditions, energy storage is typically used to mitigate the variability of renewable generation and contribute to restore the interrupted supply in the network. This is a more attractive solution in economic terms than the implementation of energy storage as a stand-alone network application uncoupled from renewable generation [53].



An increased research work has been reported in recent years that assess the reliability impact of energy storage in distribution networks (see Table 3). Modelling the time-dependent performance, the availability and the restoration strategy of energy storage are the main properties used to evaluate the techniques for their reliability assessment.

#### 4.2.1. Time-dependent performance of energy storage

One of the most relevant tasks for reliability assessment with energy storage is to simulate its charge and discharge performance during the fault period. The charge takes place at generation excess conditions and the discharge under generation shortage conditions. The chronological evolution of generation and load has to be considered as shown Figure 2. Sequential Monte Carlo simulation (SMCS) is typically used for the reliability assessment in this case because it permits the inclusion of the generation and load profiles. The evolution of the state of charge (SOC) with the charge and discharge processes needs to be calculated and is determined by (1). The capacity and the power limits of the energy storage system are also respected in the calculation in (2)-(3).

$$SOC(t+1) = SOC(t) + \frac{\Delta t}{Ce} \left( Pc(t)\eta_c - \frac{Pd(t)}{\eta_d} \right) \quad (1)$$

$$SOC_{min} \leq SOC(t) \leq SOC_{max} \quad (2)$$

$$(Pc_{min}, Pd_{min}) \leq (Pc(t), Pd(t)) \leq (Pc_{max}, Pd_{max}) \quad (3)$$

where  $\Delta t$  is the duration of time step  $t$ ,  $Ce$  is the capacity of the energy storage,  $Pc(t)$  and  $Pd(t)$  are the charge and discharge powers,  $\eta_c$  and  $\eta_d$  are the efficiency to charge and discharge,  $SOC_{min}$  and  $SOC_{max}$  are the minimum and the maximum of SOC, and  $Pc_{min}, Pd_{min}$  are the minimum power to charge and discharge, and  $Pc_{max}, Pd_{max}$  are the maximum power to charge and discharge the energy storage.

Known procedures to determine the SOC evolution in reliability assessment techniques based on SMCS are reported in [53, 54, 55, 56, 38, 57]. Hourly profiles of load and variable generation are used to assess the contribution of energy storage. In spite of the accuracy and the simplicity in modelling the stochastic nature of the problem by using SMCS, some analytical techniques have been reported for the reliability assessment of energy

storage combined with renewable DG [58, 59]. The principal objective is to take advantage of the computational efficiency of analytical techniques. However, accuracy limitations in the calculation of the SOC evolution in a probabilistic way compared to MCS are introduced. Hence, specific probabilistic models for chronological calculation of the SOC are required for the analytical techniques. In [58] a probabilistic battery state model consists of multiple states of charge and their associated probabilities are used. The probability of the battery holding a particular SOC is calculated for each time frame. However, the number of SOC states is limited by the complexity of the model. Alternative analytical techniques capable of assessing the time-dependency of load and generation [43, 28] present more options for including the chronological behaviour of load and generation in the SOC calculation.

The SOC of the energy storage at the moment when the fault is registered (or initial SOC) affects the evolution of the SOC and, therefore, to the reliability. A typical and simple criterion in the reliability assessment assumes the energy storage fully charged when the fault is registered [53, 54, 57]. A more realistic alternative is to consider a certain SOC level [60, 59]. The initial SOC can be established by the distribution network operator in order to guarantee specific reliability requirements. However, there is uncertainty related to the SOC at the moment when the fault occurs. To consider this uncertainty, in [58] the initial SOC and its probability are determined from the probabilistic battery state model that consists of multiple SOC states. An alternative is to sample the initial SOC by Monte Carlo simulation. Cumulative distribution function or a set of scenarios with their probability can be also sampled.

#### *4.2.2. Reliability models*

Another aspect to include in the reliability assessment of energy storage is the component failures. Previous reliability assessment techniques considered the performance of energy storage fully reliable without any failures. However, the components of the energy storage are exposed to failures and their impact on reliability needs to be quantified. A simple solution is to adopt the traditional two state Markov model used for conventional components in distribution networks. Another option is to apply a cumulative distribution function of the battery availability [61]. However, failures of different components of the energy storage system are not distinguished. In [59] a multistate Markov model considering the failures of the battery, the controller and the inverter is used. It is recommendable to include also the

availability of specific energy storage technologies and their components.

#### *4.2.3. Reliability impact of restoration strategies*

The strategy selected for operating the energy storage under emergency conditions can improve the reliability at several levels [62]. One option is to provide stored energy as long as possible when faults occur [53]. An alternative for using the stored energy is to reduce the demand at peak periods when there is a higher fault probability [55]. Other option is to use the stored energy only if all the load can be restored during the whole duration of the fault period [54]. Moreover, there are restoration strategies that mitigate the fluctuations of hybrid systems consisting of wind generation, PV and energy storage [58, 59].

A coordinated operation of a ESS installed in a distribution network can also be performed to improve the reliability of the bulk supply power system [56].

Mobile energy storage systems are an alternative solution to restore the interrupted supply. In [60] a methodology to assess the reliability impact of mobile energy storage systems is proposed. The time required for the operation of the mobile storage is taken into account when calculating the interruption duration.

The existing restoration strategies for reliability assessment do not consider an optimal use of energy stored over the duration of emergency period. In a similar way to the operation of energy storage under normal operating conditions when the optimisation criterium is to maximise the integration of renewables [55] or to optimise the energy purchasing cost [54], the optimal use of the energy storage in the restoration strategies provides more realistic results of energy storage contribution to the distribution network reliability. The power to charge and discharge, in addition to the time-intervals, can be optimized with an aim to minimise the energy not supplied or the interruption costs. At the same time, the system requirements will be satisfied. For example, in [59] a hybrid system consisting of wind generation, PV and energy storage is operated to minimise the power interrupted in the distribution system.

#### *4.2.4. Impact on reliability of energy storage location, size and technologies*

Location and size of energy storage are a design criteria with a relevant impact on distribution network reliability. These parameters are considered

during the planning of distribution networks as well as the reliability assessment. In [57, 63] methodologies for optimal location and size of energy storage were proposed to maximize reliability improvements. [64] proposes a methodology for an optimal planning of battery energy storage system considering the reliability benefits and the operation strategy.

Also, a variety of different energy storage technologies [65] are available. Their specific functional details have to be considered by the reliability evaluation techniques. Charge and discharge powers, capacity, efficiency, ramps to charge/discharge and reliability of the components depends on the technology. Consequently, these features influence the performance of the energy storage and the network reliability. An accurate comparison of energy storage technologies during the planning stage requires a detailed modelling of their specific properties for the reliability assessment and more research is necessary in future. Generic energy storage systems or batteries are normally considered in the reliability assessment (see Table 3). Different types of battery technologies (lead acid, pressed air, sodium sulfur, redox) are compared in the reliability assessment by [57]. The lifetime of certain energy storage technologies like electrochemical batteries depends on their use and these effects need to be included in the reliability assessment procedure.

### 4.3. Microgrids

In addition to power systems, microgrids are an example of novel technological solutions introduced, among other reasons, with the aim of improving the reliability. A microgrid is a subsystem of a distribution network that includes distributed energy resources like DG (both dispatchable and not-dispatchable) and energy storage and can be isolated from the rest of the network in case of supply interruption or inadequate power quality [66]. Therefore, two modes of operation are possible in a microgrid: connected to the network in normal operating conditions or isolated from the network under fault conditions. In grid connected mode the distributed resources within the microgrid are operated to optimize the operating costs, while in the islanded mode the aim is to restore the supply by using the local energy resources.

As a result, islanded operation represents a potential solution for the reliability improvement of the loads within the microgrid. While the conventional techniques for the reliability assessment can be applied to load points outside a microgrid, new considerations are required to determine reliability at load points within the microgrid operated in the islanded mode. Mainly for this

Table 3: Comparison of techniques for reliability assessment of energy storage

Ref.	Technique	Reliability Model	Purpose	Technology
[38], [53]	SMCS	Fully reliable	Restore supply in isolated areas with DG/without DG	Generic
[54], [56]	SMCS	Fully reliable	Improve reliability and economy operation in combination with renewable DG	Generic
[55]	SMCS	Fully reliable	Reduce the peak demand at moments of higher interruption probability	Generic
[57]	SMCS	Fully reliable	Optimal energy storage allocation for reliability improvements	Batteries
[58]	Analytical	Fully reliable (SOC levels)	Mitigates fluctuations of autonomous systems with wind and PV generation	Battery
[61]	Hybrid	Cumulative distribution function	Mitigate the fluctuations of renewable DG in microgrids	Battery
[59]	Analytical	Markov model of ESS components	Minimize energy not supplied and interruption cost in autonomous systems	Battery
[60]	Analytical MCS	Markov model	Mobile batteries to support the restoration of the interrupted supply	Battery

reason, there are several analysis in literature addressing the reliability of microgrids.

The techniques for reliability assessment of microgrids need to include the contribution of supply restoration provided by isolated operating mode. In addition to this extensions, a definition of new indices for quantifying the reliability of microgrids is necessary. Microgrids are not always regulated by the policies of the distribution network and new indices as those proposed in [67] can be more valuable for evaluating the reliability of the customers connected to a microgrid.

#### 4.3.1. Operating modes and technologies used in adequacy assessment

The principles for reliability evaluation of microgrids in islanded operation mode are similar to those described in Section 4.1.2 for distribution networks with DG in islanded mode. The adequacy of generation and load is the basic principle for the assessment of the restoration capacity of microgrids. The

distributed energy resources and the network operation to supply the demand have to be considered in the adequacy assessment. The principal techniques are shown in Table 4. Typically both dispatchable and non-dispatchable DG are used to restore the supply and the load shedding actions of non-critical loads are implemented in order to achieve the adequacy in the case of generation shortage [68, 22, 69]. Energy storage can also be integrated to mitigate the variability of generation and load [67, 70, 71, 61]. Other resources like electric vehicles are considered in [71] and demand response actions described in Section 4.4 can be applied to reduce the demand.

While microgrids are typically operated in islanded mode to enhance the reliability of the customers connected to them (see Table 4), they can be also operated to provide additional power to the distribution network in the grid connected mode. Under fault conditions in the distribution system, the power excess of the microgrid can be supplied to the distribution network and enhance its reliability. Some techniques assess the reliability contribution of microgrids in the grid-connected mode [72, 73], in addition to the assessment of the islanded mode. In these publications, microgrids operating in grid connected mode are modelled as virtual power plants and contributes to increase the transfer capacity of alternative feeders.

Both analytical [68, 22, 73] and simulation techniques [72, 72, 67, 70, 69, 71] have been used for the reliability evaluation of microgrids with DG according to the accuracy and computational times required by the analysis.

Nevertheless, Monte Carlo simulation is typically used in the presence of energy storage and time-dependent demand response actions because of the simplicity this approach provides in assessing the chronological performance compared to the analytical. Also, reliability has been evaluated for both low and medium voltage distribution networks as summarised in Table 4.

#### *4.3.2. Protection devices and microgrids operation*

The previously mentioned techniques for reliability assessment of microgrids do not consider specifically the impact of protection devices on microgrid reliability. New protection devices and protection schemes can help to increase the reliability of microgrids [74], however, their incorrect operation may compromise it. The complex operating conditions in microgrids (typical for their islanded operation), variability of renewable generation and bidirectional power flows, etc. require different settings of protection devices. As a result, the probability of undesired activation of protection devices increases. In [75] the impact of malfunctioning of protection devices is evaluated by

Table 4: Comparison of techniques for reliability assessment of microgrids

Ref.	Technique	Operating mode	Resources	Voltage level
[68], [22]	Analytical	Isolated	DG, load-shedding	MV
[73]	Analytical	Isolated and grid-connected	DG, load-shedding, energy storage	LV
[72]	Non-SMCS	Isolated and grid-connected	DG, load-shedding	MV
[67], [70]	MCS	Isolated	DG, load-shedding, energy storage	LV/MV
[71]	SMCS	Isolated	DG, energy storage, electric vehicle	MV
[61]	Hybrid analytical-simulation	Isolated	DG, energy storage, load-shedding	LV

using a model that correlates voltage/current and the outage rate of components. The uncertainty of the protection settings caused by their exposure to changeable operating conditions is assessed in [76], while the probability of triggering the protection devices is considered in [77]. A probabilistic model for the prediction of an incorrect operation of protection systems is proposed in this paper.

Frequency and voltage limits of microgrids in islanded operation represent only some of the parameters frequently ignored during a reliability assessment. This means that primary and secondary controls in microgrids, in charge of avoiding the frequency and voltage violations, are not included in the reliability assessment. In [78] the performance of primary and secondary controls of microgrids is modelled and its effect on a SMCS technique for reliability assessment included.

#### 4.3.3. Microgrid reliability as a design parameter

Apart from the evaluation of reliability assessment techniques for microgrids, the importance of the reliability of supply is crucial when it comes to planning a microgrid. Numerous methodologies [79, 80, 81] address the microgrid design taking into account the desired level of reliability.

#### 4.4. Demand Response

Demand Response (DR) is a well-known way of incentivising end-use customers to change their energy consumption habits and to reduce their electricity use at times of high market prices and high network loading (coinciding

with low grid reliability [82]). Corrective DR actions after a network fault represent a useful alternative to load shedding for the reliability improvement allowing selective disconnection of certain type of loads or shifting their use over time.

Evaluation of the impact of DR on reliability requires additional steps when compared to the conventional reliability assessment [83]. Several techniques have been proposed to deal with specific properties of DR, as Table 5 summarizes. It provides a comparative analysis of how different reliability assessment techniques address the specific characteristics of DR.

Table 5: Comparison of techniques for reliability assessment of demand response

Ref.	Technique	Operating mode	DR instrument	DR criteria	ICT impact
[84]	Analytical	Grid-connected	Incentive payments	Min interruption cost	No
[85]	SMCS	Grid-connected	Incentive payments	Disconnect/shift less critical load	No
[86], [87]	Analytical SMCS	Grid-connected	Incentive payments	Min interruption cost and payback incentives	Yes
[88]	SMCS	Islanded	Electricity price (TOU pricing)	Max incomes of supplier / Min payments to customers	No
[89]	SMCS	Islanded	Incentive payments	Min interruption cost	Yes

#### 4.4.1. Reliability indices for DR

The first consideration to evaluate the DR impact on reliability is to distinguish between interruptions caused by DR actions and by component failures. In this respect, the impact of interruptions caused by DR is less significant (loads interrupted are the less critical ones) and the interruptions are known in advance. Therefore, new reliability indices that differentiate between interruptions caused by DR actions are required. In [83] a new set of indices is proposed for this purpose.

#### 4.4.2. DR capacity

The capacity of DR actions to shift load or disconnect certain type of loads needs to be evaluated and integrated in the reliability assessment procedure. The potential of DR application is defined by the responsive appliances and



loads, the moment when DR can be applied and by the reduction it can provide [84]. As the DR capacity is linked to the time-dependent evolution of load, the DR reliability assessment needs to model the time-evolution of load patterns. That is the reason why load profiles are commonly used to model the load in the reliability assessment. In addition, SMCS is the approach frequently used [85, 87, 88, 89] to assess the reliability, although other analytical techniques based on the reduction scenarios techniques were also proposed [84, 86].

#### *4.4.3. DR instruments*

Implementation of DR capacity relies on the attractiveness of the proposed incentives and on the willingness of the customer to change its electricity use. Basically, there are two available classes of instruments to build up the DR capacity: incentive payments for load interruption and changes in the price of electricity [82].

Incentive payment instruments are used to disconnect loads of customers under fault conditions or violations of network constraints. A selective disconnection of loads can help to mitigate the impact of the load interrupted. The most attractive criteria to implement DR instruments based on incentive payment is to minimize the total interruption cost and it is considered in the methodologies for reliability assessment as shown in Table 5. Criticality of the load is another criteria [85, 90] and an inclusion of the payback incentives in addition to the interruption cost for customers is recommended [87].

Price-based DR instruments provide time-varying rates to incentivise customers to use less electricity at high-price times intervals. As a result, load can be decreased selectively and shifted over time. Time-of-use (TOU) pricing is, therefore, a price-based instrument that can be used to improve the reliability. In [88] the reliability evaluation of a TOU tariff is evaluated by considering different criteria when calculating the tariff like a minimization of the customers payment or a maximization of the supplier revenues. Implementing differentiated reliability services is an alternative for an effective DR application. Adapted pricing schemes based on the outage costs, reliability indices or customers priority can be applied to customers in distribution networks [91]. As a result, the customers can be offered different levels of reliability. Finally, the methodologies for evaluating the reliability impact of price based instruments are not as frequently used as those for incentive-based instruments as the latter are capable of mitigating the impact of fault conditions in the network.

The effectiveness of both types of DR instruments to improve reliability is somewhat uncertain. The willingness of customers to implement the DR programs depends on probabilistic factors [92] that need to be included in the reliability assessment techniques. In [89] the willingness of customers to participate in DR is determined by their historical profitability levels and includes the human behaviour and external motivators.

#### *4.4.4. DR application in different network modes*

Under fault conditions in the distribution network, the DR instruments can be applied to improve the reliability of the network in both grid-connected mode and islanded mode[15]. In grid-connected mode, the alternative feeders normally used to restore the interrupted supply, can violate the operational limits of the network making the supply restoration infeasible. By implementing DR actions, the demand can be decreased and the network constraints alleviated. The reliability improvement achieved by this application of DR is evaluated in [84, 85, 87].

The application of DR in islanded mode of distribution networks or microgrids helps achieve the adequacy of load and generation in the isolated area. DR reduces the demand in the island that needs to be supplied by the distributed energy resources. The impact of DR on reliability in this operating mode is evaluated in [88, 89].

In both operating modes, the operational performance of protection devices needs to be modelled. The modelling includes the interruption of supply during the switching time required by the protection devices and during this time DR actions can take place. The shifting or interruption of the load leads to an improvement in the reliability [84].

#### *4.4.5. ICT and smart grid technologies for DR*

A successful implementation of DR relies on the network integration of ICT and control technologies. ICT technologies are crucial for the information exchange between the agents involved, while automatic control technologies permit the actuation of the loads that needs to be disconnected. However, the elements of these technologies are exposed to failures and it is necessary to model them in the reliability assessment procedure. Table 5 shows the methodologies that consider the effect of ICT and control devices required for the DR implementation [86, 87, 89]. A two state Markov model is typically used.

## 4.5. Electric Vehicles

Electric Vehicles can also be used to improve the reliability of distribution networks by offering their services to the operator. One option is to improve the reliability under fault conditions by interrupting the EV charging without penalty until extra generation becomes available [93]. As a result, the demand is selectively reduced and its contribution on reliability can be quantified by using the techniques and principles described for demand response in Section 4.4.

Another service that electric vehicles can offer is to supply additional energy back to the grid or the customers in vehicle-to-grid (V2G) and vehicle-to-home (V2H) operating modes [94] respectively. The reliability contribution of V2G in distribution networks is evaluated in [94, 95] for parking lots and in [94] for V2H mode applied to dispersed customers. In both operating modes of electric vehicles the contribution to the reliability of distribution system can be evaluated in a similar way to the distributed energy storage [95] and, hence, the principles described in Section 4.2 for energy storage are applicable. However, some specific details need to be included in the reliability assessment of electric vehicles when supplying energy under fault conditions. The probabilistic capacity and availability of electric vehicles to inject power back to the grid has to be modelled taking into account uncertainties like the charge and discharge operation and the number of vehicles. In [95] a set of possible scenarios are selected for parking lots and the energy that each one can supply is determined from an optimization problem which minimizes cost of electricity for charging and maximizes the reward for the EV users. In [94] the reversible power is calculated for both V2H and V2G modes and for centralized (parking lots) or decentralized (individual users) schemes. In previous references, Monte Carlo simulation is used to assess the uncertainty of EV performance and hourly profiles are used when considering the demand.

Another important aspect to be considered in the reliability assessment is the strategy used by the DSO for discharging the stored energy in electric vehicles. Interruption cost or load priority are typical strategies for supply restoration. [96, 97] evaluate the interruption cost of a distribution network with electric vehicles connected. Nevertheless, for those customers with equal priority new strategies based on a fair distribution of the resources represent an interesting alternative [95].

## 4.6. Automation of protection devices

After a disturbance is identified in a distribution system, the reconfiguration of the network by automatic protection devices and protection schemes can reduce the number and duration of the interruptions and improve the reliability [98]. In addition to that, these technologies allow an efficient network reconfiguration for the supply restoration by DERs and demand response schemes.

### 4.6.1. Automatic protection devices

A deployment of automatic reclosers and telecontrolled switches in distribution networks represents a clear improvement over the application of conventional manually-operated protection devices because they significantly reduce the actuation time after a fault. Automatic reclosers and telecontrolled switches allow autonomous service restoration after a fault and a fast actuation on tripped switches. The performance of these automated protection devices needs to be reflected in the techniques for reliability assessment of distribution networks and recommendations for their modelling are given in [99]. A comparison of the techniques proposed for reliability assessment is shown in Table 6. The reliability impact of automatic reclosers is assessed in [100] by using an analytical methodology based on the state enumeration techniques and minimal cut set theory. Improvements in the distribution network reliability introduced by automatic switches were assessed in [101] where Monte Carlo simulation was used.

Techniques for the reliability evaluation of telecontrolled switches are proposed in [23, 102] and are used for the configuration of the network previous to restoration by intentional islanding of DG. It is normally assumed that telecontrolled switches are reliable, however, they are also exposed to malfunctioning and communication problems. In [103] an extension to the reliability assessment techniques for telecontrolled switches was performed and the effects of their malfunctioning included.

### 4.6.2. Automatic protection schemes

Automatic protection devices in distribution network are usually operated according to a specific strategy for fault detection, isolation and reconfiguration. The aim is to reduce the number and duration of interruptions.

Different automation schemes provide different levels of reliability. Identifying the most appropriate feeder automation scheme represents a challenge

Table 6: Comparison of techniques for reliability assessment of automatic protection devices

Ref.	Technique	Protection device	ICT impact	DG restoration
[100]	Analytical	Automatic re-closer	No	No
[101]	MCS	Automatic switches	No	No
[23], [102]	Analytical	Telecontrolled	Yes	Yes
[103]	-	Telecontrolled (malfunctioning)	Yes	No

for the distribution system planning [104]. Therefore, techniques need to address the impact of the automation schemes on distribution system reliability and some methodologies were proposed in [105, 104, 106] to deal with this purpose.

In addition to fast detection and isolation of the fault, automated distribution networks can count on alternative restoration routes through different feeders. A methodology for reliability evaluation of automation schemes that allows restoration by distributed energy resources in islanded operation was proposed in [74].

The implementation of automation schemes assumes the installation of new equipment that is prone to failure as well. The reliability impact of these components must be included in the overall reliability assessment [105, 107]. Some of the previous techniques [102, 103] (see Table 6) include the effect of failures in telecontrol communication infrastructure. The following section discusses some of the methodologies proposed for the overall assessment of the communication system.

#### 4.7. ICT technologies

Most of the modern network technologies deployed in Smart Grids depend on Information and Communication Technologies (ICT) for their correct operation [108]. It is important to bear in mind that the ICT can also fail and the reliability of distribution networks can be compromised. Traditional reliability assessment techniques for distribution systems include only the physical electricity network for energy supply but not the communication network and it is necessary to combine the reliability assessments for both in order to obtain more realistic reliability assessments. A survey of some of

the latest studies and findings in the literature about the impact of communication imperfections on the smart grid reliability can be found in [109].

## **5. A Case Study: Selection of the technique for a Reliability Assessment**

A wide range of methods used for the reliability assessment of modern distribution networks have been reviewed in the previous sections. The qualitative information provided helps select the most adequate techniques for the specific reliability assessment. However, this choice is conditioned by the technological solutions applied in the specific networks, the necessary precision of the results, the topology of the network, etc. Moreover, the qualitative analysis provided is useful for the selection of the technique, yet it is often the quantitative information like the accuracy of the results and computational times that sets the distinguishing criteria for the particular case of study.

This section provides an illustrative case study for the selection of the reliability assessment technique. A specific test network is used representing a modern distribution network with several technologies deployed. Firstly, the qualitative selection of the technique for the reliability assessment is performed. All the requirements and considerations used for the selection process are described. Then, the quantitative comparison of the selected techniques meeting the previous qualitative requirements is presented. It is important to notice that this is only a specific assessment applied to this case study. Therefore, this section does not aim to compare qualitatively all the techniques mentioned in the paper, but to present the guidelines how to select the most adequate method for this particular case.

### **5.1. Test Network**

The network used in this example is Bus 2 of the well-known Roy Billinton Test System [110] that has been frequently found in the literature that addresses reliability studies in distribution networks. It is shown in Figure 5, where the following modifications and assumptions were considered:

- The NOPs between feeders 1-2 and 3-4 in the original network were removed for the evaluation of the contribution of the islanded operation in these feeders
- Cables were used, the breakers were assumed to be 100% reliable and the network maintenance effects were not included

- Load profiles based on a real demand [111] and preserving their peak load properties as specified in [110] were used
- Reliability indices of the 33 kV [110] substation were not considered

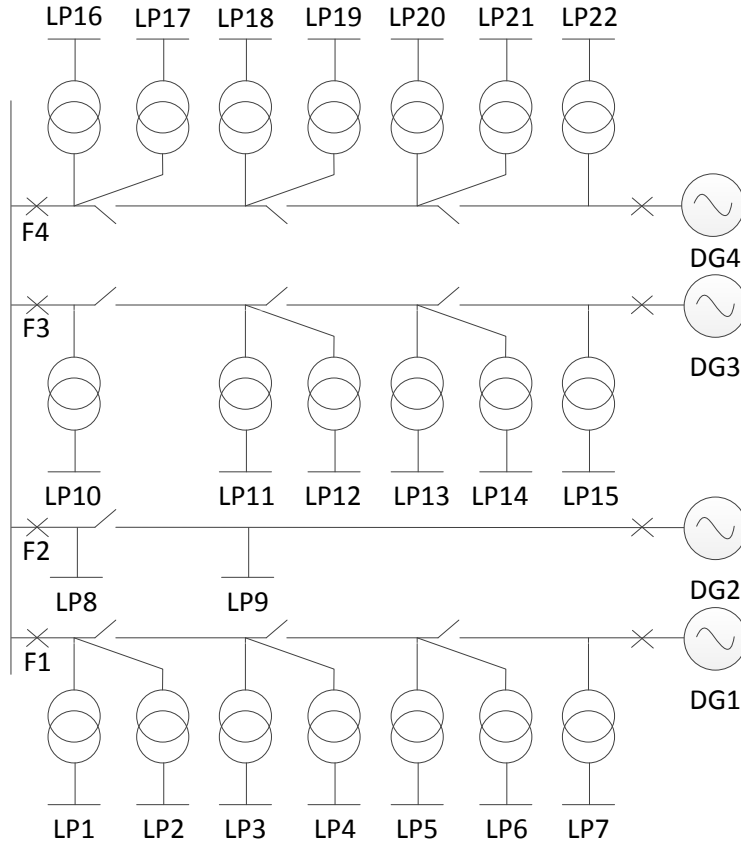

Figure 5: Diagram of the Test Network considered

Two scenarios for the reliability improvement of the reference network were used:

1. DG in islanded operation: one DG unit was installed at the end of each feeder. Characteristics of the total of four DG units used in this study are given in Table 7 and data for renewable generation as in in [111] were used.
2. Energy Storage: Energy storage systems in Table 8 were used to mitigate the variability of renewable DG units in Scenario 1.

Table 7: Parameters of DG units in Scenario 2

Type	Location	Rated power (MW)	Starting time	FOR	
DG1	Solar	LP7	3.6	0.5	0.021
DG2	Wind	LP9	2.1	0.5	0.028
DG3	Wind	LP15	3	0.5	0.028
DG4	Dispatchable	LP22	3.3	1	0.006

Table 8: Parameters of the Energy Storage units in Scenario 3

	Location	Capacity (MWh)	Rated power charge (MW)	Rated power discharge (MW)
ES1	DG1	7.1	1.1	1.1
ES2	DG2	4.2	0.6	0.6
ES3	DG3	6.1	0.9	0.9

## 5.2. Selection of the technique for reliability assessment

The adequate techniques for the reliability assessment were selected for each scenario.

### 5.2.1. Scenario 1: DG in islanded operation

The additional modelling features implemented for the reliability evaluation of the DG in Scenario 1 include:

- Reliability model of DG: the well-known two state Markov model [1] was used for considering the unavailability of the DG units.
- Configuration of the island: the operation of the protection devices under fault conditions was simulated in order to determine the switching time for the islanded configuration as in [22]. The starting time of the generators was also considered in the calculation of the island configuration time.
- Generation and load model: since renewable DG had to be evaluated, generation and load models capable of evaluating the time dependent variability of generation and load were used. SMCS approach using hourly profiles of generation and demand for a year [36] was a valid option to deal with the requirements. The analytical approach based on representative time segments of generation and load as in [28] was also an adequate choice.



- Restoration strategy: repetitive interruptions in restored customers were avoided. Therefore, the restoration strategy in [28] was implemented.

### 5.2.2. Scenario 2: Energy Storage

For the reliability assessment of the network under Scenario 2, the following extensions in the technique proposed for DG in Scenario 1 were necessary in order to assess the contribution of energy storage on reliability:

- Reliability model for ESS: a two state Markov model was used for the availability of real energy storage systems.
- Configuration of the island: the starting time of the energy storage systems was also considered in the calculation of the island configuration time.
- Chronological performance of energy storage: an accurate evaluation of the SOC was obtained by modelling the evolution of charge and discharge processes over the restoration period. Equations (2)-(3) were commonly adopted to deal with this purpose. Hourly profiles of generation and load were used, and SMCS was the approach used to assess these profiles chronologically.
- Restoration strategy: the same restoration strategy as in Scenario 1 was used. The energy storage devices were charged and discharged with the objective to extend the restoration capability of renewable DG while avoiding repetitive interruptions in restored customers.
- Storage technology: the functional details of the energy storage devices were modelled during the assessment. In this case study two models for the energy storage were considered, designed as ideal and real model. The ideal model does not consider the maximum and the minimum SOC (SOCmin, SOCmax), the efficiency of charging and discharging ( $\eta_c, \eta_d$ ) and the failures in the energy storage systems, while these parameters were taken into account by the real model. Table 9 shows the functional parameters of ideal and real energy storage.

Table 9: Parameters for real and ideal models of the energy storage systems in Scenario 2

Model	Initial SOC	SOC min	SOC max	$\eta_c$	$\eta_d$	FOR	Start time
Ideal	1	0	1	1	1	0	0
Real	0.8	0.2	0.8	0.9	0.85	0.02	0.1

### 5.3. Comparison of the results for the implemented techniques

In accordance with the previous discussion, the techniques identified as valid for the reliability assessment of this test network were implemented and applied to Scenarios 1 and 2. Scenario 1 was evaluated by the SMCS and the analytical technique introduced in Section 5.2.1. Scenario 2 was evaluated by the two methods discussed in Section 5.2.1, one assuming an ideal energy storage system and the other considering a real device.

The results obtained by the reliability assessment techniques for both scenarios are shown in Table 10. A coefficient of variation of 0.02 [112] was used to stop the Monte Carlo simulation. SAIDI and ENS indices were used to assess the effect of the DG and the energy storage on the interruption duration. The number of interruptions did not change because the switching time was required to configure the island and repetitive interruptions in restored customers were avoided.

In Scenario 1, the comparison of reliability indices shows that both SMCS and analytical techniques provide practically the same results. Differences of 0.1% were obtained, lower than the coefficient of variation, although a 133 times longer computational time was needed by SMCS. Therefore, it can be concluded that the analytical technique used is a more efficient solution to compute the reliability indices in Scenario 1.

The comparison of the reliability indices provided by the ideal and real energy storage models in Scenario 2 shows a difference of 0.4% in SAIDI and 0.6% in ENS. These differences were conditioned by the limited contribution of energy storage to enhance the reliability in Scenario 2 (for example, SAIDI was reduced from 5.157 in Scenario 1 to 5.068 and 5.09 for ideal and real storage models in Scenario 2). The computational times required for both storage models are practically the same. From this comparison it can be concluded that by using an ideal model of energy storage instead of a real one does not cause significant changes in the reliability indices. However, this can change in some other scenarios when the energy storage has more impact on the reliability.

Table 10: Comparison of the techniques for reliability assessment in Scenarios 1 and 2 (reliability indices and computational time)

a	Scenario 1			Scenario 2		
	SMCS	Analytical	Diff.	Ideal storage	Real storage	Diff.
SAIDI	5.157	5.164	0.1%	5.068	5.09	0.4%
ENS	50.26	50.31	0.1%	47.99	48.26	0.6%
Time	80.1	0.6	79.5 s	108.5	109.3	0.8 s

<sup>a</sup> SAIDI in hours of interruption per year and customer, ENS in MWh/year, Time in seconds

## 6. Concluding remarks

The introduction of new technologies in modern distribution networks (DG, energy storage, microgrids, demand response, electric vehicle, automated protection devices) opens up new opportunities to improve the reliability. This paper presented a survey of the techniques proposed for the reliability assessment of distribution networks. The modelling requirements and the properties of the methodologies in the field were compared and critically reviewed by technology. In addition, a case study was introduced to illustrate the modelling procedure of reliability assessment techniques as well as the comparison of the results computed by the techniques modelled. The survey provides the state-of-the-art in the topic and the necessary details for the implementation of the reliability assessment techniques.

From a general point of view, the survey presented the intensive research efforts focused on modelling the features, complexities and uncertainties necessary for the reliability assessment of distribution networks. In this sense, the publications have taken significant attention to the stochastic nature of aspects like the variability of load and generation, the performance of energy storage, the estimation of demand response capacity and the opportunities introduced by electric vehicles.

Research in the field has also been focused in operational aspects of modern distribution networks. Intentional islanding and microgrids has been identified as a promising opportunity to improve the reliability of supply. To assess the reliability under this operating mode, adequacy evaluation of generation and load is the core criteria considered by the techniques. Consequently, all those factors that influences on the adequacy of the island are important to be considered in the assessment.

Another operational aspect affecting the reliability of distribution net-

works is the strategy implemented to restore the supply, this is, how the technologies evaluated are used under fault conditions to reduce the impact of the supply interruptions. The techniques requires to model realistic restoration strategies for accurate assessment.

The approach typically used in literature by the techniques for reliability assessment is Monte Carlo simulation. The stochastic nature of simulation approach allows to address the complexities and uncertainties of modern distribution networks accurately. However, an alternative research trend based on analytical techniques has been identified, promoted by their reduced computational times compared to simulation. The research work in this trend has been mainly focused on DG, while some simplified models has been proposed for energy storage. New modelling work in the analytical techniques should consider the complexities, the assumptions and the results accuracy.

This survey also reveals specific findings for each of the technologies considered. Islanded operation of DG is the technological solution with more techniques proposed for reliability evaluation due to its promising capacity to restore the supply in areas isolated by faults. Among the models proposed in the literature to assess the variability of renewable DG, the most realistic results are provided by those ones that considers the chronological fluctuations of generation and load during the fault duration. For the case of DG in grid-connected mode, the techniques implemented for reliability assessment focus on quantifying the transfer capacity increase caused by the generation. Energy storage applied to mitigate the fluctuation of renewable generation under fault conditions has been modelled by simulating the charges and discharges processes. Behaviour factors (customers willingness, journey habits), environmental conditions and financial instruments (incentive payments, tariff, vehicle-to-grid, vehicle-to-home) have been introduced in the methodologies for evaluating the impact of demand response and electric vehicle on reliability. The field of protection devices automation and their contribution on reliability has been focused on modelling the operation of new devices and schemes under fault conditions. The survey also distinguishes the importance of the development of new techniques for the reliability assessment of the ICT systems used across modern distribution networks.

The case study illustrated the survey benefits for developing the reliability assessment techniques that accomplish with specific requirements. These techniques were implemented and used to evaluate the reliability of the case

study under different scenarios. The results demonstrated that accuracy and computational efficiency are also relevant factors to be considered in the selection of the reliability assessment techniques.

The opportunities identified for future research in this topic are to implement more advanced restoration strategies in the methodologies for reliability assessment, develop computational-efficient techniques alternative to Monte Carlo simulation, model specific features of energy storage technologies in the reliability assessment, propose new reliability assessment tools for an integrated evaluation of modern distribution networks and develop techniques for evaluating the impact on reliability of other network technologies like FACTS or SNOPs.

### **Acknowledgments**

The authors kindly acknowledge the support of the Spanish Ministry of Economy and Competitiveness project RESmart (ENE2013-48690-C2-2-R).

### **References**

- [1] R. Billinton, R. Allan, Reliability Evaluation of Power Systems, 2nd Edition, New York, 1996.
- [2] Smart Grids Security and Resilience Task Force, The need for a fundamental review of electricity networks reliability standards (White Paper), Tech. rep. (2016).
- [3] K. Moslehi, R. Kumar, A reliability perspective of the smart grid, *IEEE Transactions on Smart Grid* 1 (1) (2010) 57–64. doi:10.1109/TSG.2010.2046346.
- [4] M. Cepin, Assessment of Power System Reliability, Methods and Applications, London, 2011.
- [5] R. Billinton, Bibliography on the application of probability methods in power system reliability evaluation, *IEEE Trans. Power App. Syst.* PAS-91 (2) (1972) 649–660. doi:10.1109/TPAS.1972.293251.
- [6] P. S. E. Committee, Bibliography on the application of probability methods in power system reliability evaluation 1971-1977, *IEEE Trans. Power App. Syst.* PAS-97 (6) (1978) 2235–2242. doi:10.1109/TPAS.1978.354727.

- [7] R. N. Allan, R. Billinton, S. H. Lee, Bibliography on the application of probability methods in power system reliability evaluation 1977-1982, *IEEE Trans. Power App. Syst. PAS-103* (2) (1984) 275–282. doi:10.1109/TPAS.1984.318226.
- [8] R. N. Allan, R. Billinton, S. M. Shahidehpour, C. Singh, Bibliography on the application of probability methods in power system reliability evaluation: 1982-1987, *IEEE Trans. Power Syst.* 3 (4) (1988) 1555–1564. doi:10.1109/59.192965.
- [9] R. N. Allan, R. Billinton, A. M. Breipohl, C. H. Grigg, Bibliography on the application of probability methods in power system reliability evaluation: 1987-1991, *IEEE Trans. Power Syst.* 9 (1) (1994) 41–49. doi:10.1109/59.317559.
- [10] R. Billinton, M. Fotuhi-Firuzabad, L. Bertling, Bibliography on the application of probability methods in power system reliability evaluation 1996-1999, *IEEE Trans. Power Syst.* 16 (4) (2001) 595–602. doi:10.1109/59.962402.
- [11] S. Chapel, Reliability of electric utility distribution systems: EPRI white paper, Final Rep.
- [12] R. Allan, R. Billinton, Probabilistic assessment of power systems, *Proceedings of the IEEE* 88 (2) (2000) 140–162. doi:10.1109/5.823995.
- [13] H. M. Lopes-Ferreira, H. Faas, G. Fulli, W. Kling, J. P. Lopes, Reliability analyses on distribution networks with dispersed generation: a review of the state of the art, in: *Conf. Smart Electricity Systems and Interoperability*, 2010, pp. 1–17.
- [14] J. Lin, L. Cheng, Y. Chang, K. Zhang, B. Shu, G. Liu, Reliability based power systems planning and operation with wind power integration: A review to models, algorithms and applications, *Renewable Sustainable Energy Rev.* 31 (2014) 921–934. doi:http://dx.doi.org/10.1016/j.rser.2013.12.034.
- [15] C. L. T. Borges, An overview of reliability models and methods for distribution systems with renewable energy distributed generation, *Renewable Sustainable Energy Rev.* 16 (6) (2012) 4008–4015. doi:http://dx.doi.org/10.1016/j.rser.2012.03.055.

- [16] R. E. Brown, L. A. A. Freeman, Analyzing the reliability impact of distributed generation, in: Power Engineering Society Summer Meeting, Vol. 2, 2001, pp. 1013–1018 vol.2. doi:10.1109/PESS.2001.970197.
- [17] J. E. Kim, J. S. Hwang, Islanding detection method of distributed generation units connected to power distribution system, in: Proc. Int. Conf. Power System Technology, Vol. 2, 2000, pp. 643–647 vol.2. doi:10.1109/ICPST.2000.897098.
- [18] Ieee guide for electric power distribution reliability indices, IEEE Std 1366, 2001 Edition doi:10.1109/IEEESTD.2001.94438.
- [19] R. Billinton, P. Wang, Teaching distribution system reliability evaluation using monte carlo simulation, IEEE Trans. Power Syst. 14 (2) (1999) 397–403. doi:10.1109/59.761856.
- [20] T. Kaipia, P. Peltoniemi, J. Lassila, P. Salonen, J. Partanen, Power electronics in smartgrids - impact on power system reliability, in: CIRED Seminar 2008: SmartGrids for Distribution, 2008, pp. 1–4. doi:10.1049/ic:20080488.
- [21] Z. ESAU, D. JAYAWEERA, Reliability assessment in active distribution networks with detailed effects of pv systems, Journal of Modern Power Systems and Clean Energy 2 (1) (2014) 59–68. doi:10.1007/s40565-014-0046-2.
- [22] S. Conti, R. Nicolosi, S. A. Rizzo, Generalized systematic approach to assess distribution system reliability with renewable distributed generators and microgrids, IEEE Trans. Power Del. 27 (1) (2012) 261–270. doi:10.1109/TPWRD.2011.2172641.
- [23] S. Conti, S. A. Rizzo, E. F. El-Saadany, M. Essam, Y. M. Atwa, Reliability assessment of distribution systems considering telecontrolled switches and microgrids, IEEE Trans. Power Syst. 29 (2) (2014) 598–607. doi:10.1109/TPWRS.2013.2287301.
- [24] C. Chen, W. Wu, B. Zhang, C. Singh, An analytical adequacy evaluation method for distribution networks considering protection strategies and distributed generators, IEEE Transactions on Power Delivery 30 (3) (2015) 1392–1400. doi:10.1109/TPWRD.2014.2376980.

- [25] E. N. Dialynas, R. N. Allan, Local generating facilities in the reliability evaluation of power distribution systems, *IEEE Trans. Power Syst.* 1 (4) (1986) 62–67. doi:10.1109/TPWRS.1986.4335017.
- [26] E. N. Dialynas, R. N. Allan, Reliability modelling and evaluation techniques for power distribution networks with local generation, *IEE Proc. C- Generation, Transmission and Distribution* 134 (5) (1987) 348–356. doi:10.1049/ip-c.1987.0058.
- [27] I. S. Bae, J. O. Kim, Reliability evaluation of distributed generation based on operation mode, *IEEE Trans. Power Syst.* 22 (2) (2007) 785–790. doi:10.1109/TPWRS.2007.894842.
- [28] K. Zou, A. P. Agalgaonkar, K. M. Muttaqi, S. Perera, An analytical approach for reliability evaluation of distribution systems containing dispatchable and nondispatchable renewable dg units, *IEEE Trans. Smart Grid* 5 (6) (2014) 2657–2665. doi:10.1109/TSG.2014.2350505.
- [29] S. Conti, G. Faraci, A. La Corte, R. Nicolosi, S. A. Rizzo, G. Schembra, Effect of islanding and telecontrolled switches on distribution system reliability considering load and green-energy fluctuations, *Applied Sciences* 6 (5) (2016) 1–26. doi:10.3390/app6050138.
- [30] Reliability assessment of distribution networks with distributed generations using monte carlo method, *Energy Procedia* 12 (2011) 278 – 286, the Proceedings of International Conference on Smart Grid and Clean Energy Technologies (ICSGCE 2011). doi:http://dx.doi.org/10.1016/j.egypro.2011.10.038.
- [31] Y. G. Hegazy, M. M. A. Salama, A. Y. Chikhani, Adequacy assessment of distributed generation systems using monte carlo simulation, *IEEE Transactions on Power Systems* 18 (1) (2003) 48–52. doi:10.1109/TPWRS.2002.807044.
- [32] R. Arya, S. Choube, L. Arya, Reliability evaluation and enhancement of distribution systems in the presence of distributed generation based on standby mode, *Int. J. Elec. Power* 43 (1) (2012) 607 – 616. doi:http://dx.doi.org/10.1016/j.ijepes.2012.05.045.



- [33] P. Wang, R. Billinton, Reliability benefit analysis of adding wtg to a distribution system, *IEEE Trans. Energy Convers.* 16 (2) (2001) 134–139. doi:10.1109/60.921464.
- [34] P. Wang, R. Billinton, Time-sequential simulation technique for rural distribution system reliability cost/worth evaluation including wind generation as alternative supply, *IEE Proc. - Generation, Transmission and Distribution* 148 (4) (2001) 355–360. doi:10.1049/ip-gtd:20010406.
- [35] J. Lin, X. Wang, Reliability evaluation for distribution system with distributed generation, in: *2010 Asia-Pacific Power and Energy Engineering Conf.*, 2010, pp. 1–4. doi:10.1109/APPEEC.2010.5448347.
- [36] G. Celli, E. Ghiani, F. Pilo, G. G. Soma, Reliability assessment in smart distribution networks, *Electr. Pow. Syst. Res.* 104 (2013) 164–175. doi:http://dx.doi.org/10.1016/j.epsr.2013.07.001.
- [37] S. Conti, S. A. Rizzo, Monte carlo simulation by using a systematic approach to assess distribution system reliability considering intentional islanding, *IEEE Trans. Power Del.* 30 (1) (2015) 64–73. doi:10.1109/TPWRD.2014.2329535.
- [38] H. Guo, V. Levi, M. Buhari, Reliability assessment of smart distribution networks, in: *2015 IEEE Innovative Smart Grid Technologies - Asia (ISGT ASIA)*, 2015, pp. 1–6. doi:10.1109/ISGT-Asia.2015.7387037.
- [39] A. Sankarakrishnan, R. Billinton, Sequential monte carlo simulation for composite power system reliability analysis with time varying loads, *IEEE Trans. Power Syst.* 10 (3) (1995) 1540–1545. doi:10.1109/59.466491.
- [40] Y. M. Atwa, E. F. El-Saadany, Reliability evaluation for distribution system with renewable distributed generation during islanded mode of operation, *IEEE Trans. Power Syst.* 24 (2) (2009) 572–581. doi:10.1109/TPWRS.2009.2016458.
- [41] M. Al-Muhaini, G. T. Heydt, Evaluating future power distribution system reliability including distributed generation, *IEEE Trans. Power Del.* 28 (4) (2013) 2264–2272. doi:10.1109/TPWRD.2013.2253808.

- [42] M. Fotuhi-Firuzabad, A. Rajabi-Ghahnavie, An analytical method to consider dg impacts on distribution system reliability, in: 2005 IEEE/PES Transmission Distribution Conf. Expo.: Asia and Pacific, 2005, pp. 1–6. doi:10.1109/TDC.2005.1547168.
- [43] S. Conti, S. A. Rizzo, Modelling of microgrid-renewable generators accounting for power-output correlation, *IEEE Trans. Power Del.* 28 (4) (2013) 2124–2133. doi:10.1109/TPWRD.2013.2265606.
- [44] A. C. Neto, M. G. da Silva, A. B. Rodrigues, Impact of distributed generation on reliability evaluation of radial distribution systems under network constraints, in: *Int. Conf. Probabilistic Methods Applied to Power Systems (PMAPS)*, 2006, pp. 1–6. doi:10.1109/PMAPS.2006.360421.
- [45] S. S. Duttgupta, C. Singh, A reliability assessment methodology for distribution systems with distributed generation, in: 2006 IEEE Power Engineering Society General Meeting, pp. 1–7. doi:10.1109/PES.2006.1708964.
- [46] V. A. Evangelopoulos, P. S. Georgilakis, N. D. Hatziargyriou, Optimal operation of smart distribution networks: A review of models, methods and future research, *Electric Power Systems Research* 140 (2016) 95 – 106. doi:http://dx.doi.org/10.1016/j.epsr.2016.06.035.
- [47] L. F. Rocha, C. L. T. Borges, G. N. Taranto, Reliability evaluation of active distribution networks including islanding dynamics, *IEEE Trans. Power Syst.* PP (99) (2016) 1–1. doi:10.1109/TPWRS.2016.2585648.
- [48] A. Escalera, B. Hayes, M. Prodanovic, Reliability assessment of active distribution networks considering distributed energy resources and operational limits, in: *CIREN Workshop 2016*, 2016, pp. 1–4.
- [49] W. Li, P. Wang, Z. Li, Y. Liu, Reliability evaluation of complex radial distribution systems considering restoration sequence and network constraints, *IEEE Trans. Power Del.* 19 (2) (2004) 753–758. doi:10.1109/TPWRD.2003.822960.
- [50] C. L. C. de Castro, A. B. Rodrigues, M. G. Silva, Reliability evaluation of radial distribution systems considering voltage drop constraints in

the restoration process, in: 2004 International Conference on Probabilistic Methods Applied to Power Systems, 2004, pp. 106–111.

- [51] A. M. L. da Silva, L. C. Nascimento, M. A. da Rosa, D. Issicaba, J. A. P. Lopes, Distributed energy resources impact on distribution system reliability under load transfer restrictions, *IEEE Trans. Smart Grid* 3 (4) (2012) 2048–2055. doi:10.1109/TSG.2012.2190997.
- [52] M. Abdullah, A. Agalgaonkar, K. Muttaqi, Assessment of energy supply and continuity of service in distribution network with renewable distributed generation, *Applied Energy* 113 (2014) 1015 – 1026. doi:http://dx.doi.org/10.1016/j.apenergy.2013.08.040.
- [53] D. Aming, A. Rajapakse, T. Molinski, E. Innes, A technique for evaluating the reliability improvement due to energy storage systems, in: 2007 Canadian Conf. Electrical and Computer Engineering, 2007, pp. 413–416. doi:10.1109/CCECE.2007.109.
- [54] Y. Xu, C. Singh, Adequacy and economy analysis of distribution systems integrated with electric energy storage and renewable energy resources, *IEEE Trans. Power Syst.* 27 (4) (2012) 2332–2341. doi:10.1109/TPWRS.2012.2186830.
- [55] I. Hernando-Gil, I. S. Ilie, A. J. Collin, J. L. Acosta, S. Z. Djokic, Impact of dg and energy storage on distribution network reliability: A comparative analysis, in: 2012 IEEE Int. Energy Conf. and Exhibition (ENERGYCON), 2012, pp. 605–611. doi:10.1109/EnergyCon.2012.6348224.
- [56] Y. Xu, C. Singh, Power system reliability impact of energy storage integration with intelligent operation strategy, *IEEE Trans. Smart Grid* 5 (2) (2014) 1129–1137. doi:10.1109/TSG.2013.2278482.
- [57] A. S. A. Awad, T. H. M. EL-Fouly, M. M. A. Salama, Optimal ess allocation and load shedding for improving distribution system reliability, *IEEE Trans. Smart Grid* 5 (5) (2014) 2339–2349. doi:10.1109/TSG.2014.2316197.
- [58] P. Paliwal, N. Patidar, R. Nema, A novel method for reliability assessment of autonomous pv-wind-storage system using prob-

- abilistic storage model, *Int. J. Elec. Power* 55 (2014) 692 – 703. doi:<http://dx.doi.org/10.1016/j.ijepes.2013.10.010>.
- [59] T. Adefarati, R. Bansal, Reliability assessment of distribution system with the integration of renewable distributed generation, *Applied Energy* 185 (2017) 158 – 171. doi:<http://dx.doi.org/10.1016/j.apenergy.2016.10.087>.
- [60] Y. Chen, Y. Zheng, F. Luo, J. Wen, Z. Xu, Reliability evaluation of distribution systems with mobile energy storage systems, *IET Renewable Power Generation* 10 (10) (2016) 1562–1569. doi:[10.1049/iet-rpg.2015.0608](https://doi.org/10.1049/iet-rpg.2015.0608).
- [61] C. L. T. Borges, M. Costa, Reliability assessment of microgrids with renewable generation by an hybrid model, in: 2015 IEEE Eindhoven PowerTech, 2015, pp. 1–6. doi:[10.1109/PTC.2015.7232526](https://doi.org/10.1109/PTC.2015.7232526).
- [62] P. Hu, R. Karki, R. Billinton, Reliability evaluation of generating systems containing wind power and energy storage, *IET Generat., Transm. Distrib.* 3 (8) (2009) 783–791. doi:[10.1049/iet-gtd.2008.0639](https://doi.org/10.1049/iet-gtd.2008.0639).
- [63] H. Saboori, R. Hemmati, M. A. Jirdehi, Reliability improvement in radial electrical distribution network by optimal planning of energy storage systems, *Energy* 93 (2015) 2299 – 2312. doi:<http://dx.doi.org/10.1016/j.energy.2015.10.125>.
- [64] W. LIU, S. NIU, H. XU, Optimal planning of battery energy storage considering reliability benefit and operation strategy in active distribution system, *Journal of Modern Power Systems and Clean Energy* 5 (2) (2017) 177–186. doi:[10.1007/s40565-016-0197-4](https://doi.org/10.1007/s40565-016-0197-4).
- [65] D. Rastler (EPRI), Electricity Energy Storage Technology Options, Tech. rep. (2010).
- [66] R. H. Lasseter, Microgrids and distributed generation, *J. Energy Eng.* 133 (1) (2007) 144–149. doi:[10.1061/\(ASCE\)0733-9402\(2007\)133:3\(144\)](https://doi.org/10.1061/(ASCE)0733-9402(2007)133:3(144)).
- [67] S. Wang, Z. Li, L. Wu, M. Shahidehpour, Z. Li, New metrics for assessing the reliability and economics of microgrids in distribution system, *IEEE Trans. Power Syst.* 28 (3) (2013) 2852–2861. doi:[10.1109/TPWRS.2013.2249539](https://doi.org/10.1109/TPWRS.2013.2249539).

- [68] I. S. Bae, J. O. Kim, Reliability evaluation of customers in a microgrid, *IEEE Trans. Power Syst.* 23 (3) (2008) 1416–1422. doi:10.1109/TPWRS.2008.926710.
- [69] E. N. Dialynas, L. Daoutis, Modelling and evaluation of microgrids reliability and operational performance and its impact on service quality, *Eur. T. Electr. Power* 21 (2) (2011) 1255–1270. doi:10.1002/etep.401.
- [70] H. Liang, J. Su, S. Liu, Reliability evaluation of distribution system containing microgrid, in: 2010 China Int. Conf. Electricity Distribution (CICED), 2010, pp. 1–7.
- [71] H. Bai, S. Miao, P. Zhang, Z. Bai, Reliability evaluation of a distribution network with microgrid based on a combined power generation system, *Energies* 8 (2) (2015) 1216–1241. doi:10.3390/en8021216.
- [72] Z. Bie, P. Zhang, G. Li, B. Hua, M. Meehan, X. Wang, Reliability evaluation of active distribution systems including microgrids, *IEEE Trans. Power Syst.* 27 (4) (2012) 2342–2350. doi:10.1109/TPWRS.2012.2202695.
- [73] P. M. Costa, M. A. Matos, Assessing the contribution of microgrids to the reliability of distribution networks, *Electric Power Systems Research* 79 (2) (2009) 382 – 389. doi:http://dx.doi.org/10.1016/j.epsr.2008.07.009.
- [74] M. E. Khodayar, M. Barati, M. Shahidehpour, Integration of high reliability distribution system in microgrid operation, *IEEE Trans. Smart Grid* 3 (4) (2012) 1997–2006. doi:10.1109/TSG.2012.2213348.
- [75] X. Xu, J. Mitra, T. Wang, L. Mu, Evaluation of operational reliability of a microgrid using a short-term outage model, *IEEE Transactions on Power Systems* 29 (5) (2014) 2238–2247. doi:10.1109/TPWRS.2014.2303792.
- [76] X. Xu, J. Mitra, T. Wang, L. Mu, An evaluation strategy for microgrid reliability considering the effects of protection system, *IEEE Transactions on Power Delivery* 31 (5) (2016) 1989–1997. doi:10.1109/TPWRD.2015.2440664.

- [77] X. Xu, T. Wang, L. Mu, J. Mitra, Predictive analysis of microgrid reliability using a probabilistic model of protection system operation, *IEEE Transactions on Power Systems* 32 (4) (2017) 3176–3184. doi:10.1109/TPWRS.2016.2628812.
- [78] J. R. Araújo, E. N. M. Silva, A. B. Rodrigues, M. G. da Silva, Assessment of the impact of microgrid control strategies in the power distribution reliability indices, *Journal of Control, Automation and Electrical Systems* 28 (2) (2017) 271–283. doi:10.1007/s40313-017-0299-x.
- [79] S. A. Arefifar, Y. A. R. I. Mohamed, Dg mix, reactive sources and energy storage units for optimizing microgrid reliability and supply security, *IEEE Trans. Smart Grid* 5 (4) (2014) 1835–1844. doi:10.1109/TSG.2014.2307919.
- [80] H. Baghaee, M. Mirsalim, G. Gharehpetian, H. Talebi, Reliability/cost-based multi-objective pareto optimal design of stand-alone wind/pv/fc generation microgrid system, *Energy* 115 (2016) 1022 – 1041. doi:http://dx.doi.org/10.1016/j.energy.2016.09.007.
- [81] J. Mitra, M. R. Vallem, C. Singh, Optimal deployment of distributed generation using a reliability criterion, *IEEE Transactions on Industry Applications* 52 (3) (2016) 1989–1997. doi:10.1109/TIA.2016.2517067.
- [82] U. D. of Energy, Benefits of demand response in electricity markets and recommendations for achieving them, Tech. rep. (2006, Feb).
- [83] S. Mohagheghi, F. Yang, B. Falahati, Impact of demand response on distribution system reliability, in: 2011 IEEE Power and Energy Society General Meeting, 2011, pp. 1–7. doi:10.1109/PES.2011.6039365.
- [84] A. Safdarian, M. Z. Degefa, M. Lehtonen, M. Fotuhi-Firuzabad, Distribution network reliability improvements in presence of demand response, *IET Generat., Transm. Distrib.* 8 (12) (2014) 2027–2035. doi:10.1049/iet-gtd.2013.0815.
- [85] I. S. Ilie, I. Hernando-Gil, A. J. Collin, J. L. Acosta, S. Z. Djokic, Reliability performance assessment in smart grids with demand-side management, in: 2011 2nd IEEE PES International Conference and Exhibition on Innovative Smart Grid Technologies, 2011, pp. 1–7. doi:10.1109/ISGTEurope.2011.6162650.

- [86] A. L. A. Syrri, P. Mancarella, Reliability evaluation of demand response to increase distribution network utilisation, in: 2014 Int. Conf. Probabilistic Methods Applied to Power Systems (PMAPS), 2014, pp. 1–6. doi:10.1109/PMAPS.2014.6960658.
- [87] A. L. Syrri, P. Mancarella, Reliability and risk assessment of post-contingency demand response in smart distribution networks, *Sustainable Energy, Grids and Networks* 7 (2016) 1 – 12. doi:http://dx.doi.org/10.1016/j.segan.2016.04.002.
- [88] H. Xie, Z. Bie, B. Hua, G. Li, Reliability assessment of distribution power systems considering the tou pricing, in: 2013 IEEE Region 10 Conference (TENCON 2013), 2013, pp. 1–4. doi:10.1109/TENCON.2013.6719049.
- [89] B. Zeng, G. Wu, J. Wang, J. Zhang, M. Zeng, Impact of behavior-driven demand response on supply adequacy in smart distribution systems, *Applied Energy* 202 (2017) 125 – 137. doi:http://dx.doi.org/10.1016/j.apenergy.2017.05.098.
- [90] A. Moshari, A. Ebrahimi, Reliability-based nodal evaluation and prioritization of demand response programs, *International Transactions on Electrical Energy Systems* 25 (12) (2015) 3384–3407, eTEP-14-0375.R2. doi:10.1002/etep.2041.
- [91] J. Tan, L. Wang, Enabling reliability-differentiated service in residential distribution networks with phevs: A hierarchical game approach, *IEEE Trans. Smart Grid* 7 (2) (2016) 684–694. doi:10.1109/TSG.2015.2420111.
- [92] N. Good, K. A. Ellis, P. Mancarella, Review and classification of barriers and enablers of demand response in the smart grid, *Renewable and Sustainable Energy Reviews* 72 (2017) 57 – 72. doi:http://dx.doi.org/10.1016/j.rser.2017.01.043.
- [93] N. Z. Xu, C. Y. Chung, Well-being analysis of generating systems considering electric vehicle charging, *IEEE Trans. Power Syst.* 29 (5) (2014) 2311–2320. doi:10.1109/TPWRS.2014.2307865.

- [94] N. Z. Xu, C. Y. Chung, Reliability evaluation of distribution systems including vehicle-to-home and vehicle-to-grid, *IEEE Trans. Power Syst.* 31 (1) (2016) 759–768. doi:10.1109/TPWRS.2015.2396524.
- [95] H. Farzin, M. Fotuhi-Firuzabad, M. Moeini-Aghtaie, Reliability studies of modern distribution systems integrated with renewable generation and parking lots, *IEEE Transactions on Sustainable Energy* 8 (1) (2017) 431–440. doi:10.1109/TSTE.2016.2598365.
- [96] A. Kavousi-Fard, M. A. Rostami, T. Niknam, Reliability-oriented re-configuration of vehicle-to-grid networks, *IEEE Transactions on Industrial Informatics* 11 (3) (2015) 682–691. doi:10.1109/TII.2015.2423093.
- [97] C. X. Wu, C. Y. Chung, F. S. Wen, D. Y. Du, Reliability/cost evaluation with pev and wind generation system, *IEEE Transactions on Sustainable Energy* 5 (1) (2014) 273–281. doi:10.1109/TSTE.2013.2281515.
- [98] D. Haughton, G. T. Heydt, Smart distribution system design: Automatic reconfiguration for improved reliability, in: *IEEE PES General Meeting*, 2010, pp. 1–8. doi:10.1109/PES.2010.5589678.
- [99] Y. He, G. Andersson, R. N. Allan, Modeling the impact of automation and control on the reliability of distribution systems, in: *IEEE Power Engineering Society Summer Meeting*, 2000, Vol. 1, 2000, pp. 79–84 vol. 1. doi:10.1109/PESS.2000.867415.
- [100] A. M. L. da Silva, A. M. Cassula, L. C. Resende, R. M. Almeida, M. T. Yamasaki, G. M. F. Paula, Reliability evaluation of distribution systems considering automatic reclosers, in: *2004 Int. Conf. Probabilistic Methods Applied to Power Systems (PMAPS)*, 2004, pp. 100–105.
- [101] H. Zheng, Y. Cheng, B. Gou, D. Frank, A. Bern, W. Muston, Impact of automatic switches on power distribution system reliability, *Electr. Pow. Syst. Res.* 83 (1) (2012) 51–57. doi:http://dx.doi.org/10.1016/j.epsr.2011.08.018.
- [102] S. Conti, A. L. Corte, R. Nicolosi, S. Rizzo, Impact of cyber-physical system vulnerability, telecontrol system availability and islanding on distribution network reliability, *Sus-*



tainable Energy, Grids and Networks 6 (2016) 143 – 151.  
doi:<http://dx.doi.org/10.1016/j.segan.2016.03.003>.

- [103] A. Safdarian, M. Farajollahi, M. Fotuhi-Firuzabad, Impacts of remote control switch malfunction on distribution system reliability, *IEEE Transactions on Power Systems* 32 (2) (2017) 1572–1573. doi:[10.1109/TPWRS.2016.2568747](https://doi.org/10.1109/TPWRS.2016.2568747).
- [104] S. Kazemi, M. Fotuhi-Firuzabad, M. Lehtonen, Reliability worth assessment of an advanced centralized feeder automation scheme, in: *2008 IEEE Electric Power And Energy Conf. (EPEC)*, 2008, pp. 1–8. doi:[10.1109/EPC.2008.4763311](https://doi.org/10.1109/EPC.2008.4763311).
- [105] S. Kazemi, M. Fotuhi-Firuzabad, R. Billinton, Reliability assessment of an automated distribution system, *IET Generat., Transm. Distrib.* 1 (2) (2007) 223–233. doi:[10.1049/iet-gtd:20050261](https://doi.org/10.1049/iet-gtd:20050261).
- [106] S. Kazemi, M. Lehtonen, M. Fotuhi-Firuzabad, Reliability worth assessment of an automatic loop restoration scheme for urban distribution networks, in: *2010 IEEE PES Innovative Smart Grid Technologies Conf. Europe (ISGT Europe)*, 2010, pp. 1–8. doi:[10.1109/ISGTEUROPE.2010.5638943](https://doi.org/10.1109/ISGTEUROPE.2010.5638943).
- [107] Y. He, L. Soder, R. N. Allan, Distribution automation: impact of communication system on reliability of automatic control, in: *2001 IEEE Porto Power Tech Proc., Vol. 3*, 2001, pp. 6 pp. vol.3–. doi:[10.1109/PTC.2001.964899](https://doi.org/10.1109/PTC.2001.964899).
- [108] I. A. Tondel, J. Foros, S. S. Kilskar, P.Hokstad, M. G. Jaatun, Interdependencies and reliability in the combined ict and power system: An overview of current research, *Applied Computing and Informatics*-doi:<http://dx.doi.org/10.1016/j.aci.2017.01.001>.
- [109] R. S. de Carvalho, S. Mohagheghi, Analyzing impact of communication network topologies on reconfiguration of networked microgrids, impact of communication system on smart grid reliability, security and operation, in: *2016 North American Power Symposium (NAPS)*, 2016, pp. 1–6. doi:[10.1109/NAPS.2016.7747932](https://doi.org/10.1109/NAPS.2016.7747932).
- [110] R. N. Allan, R. Billinton, I. Sjarief, L. Goel, K. S. So, A reliability test system for educational purposes-basic distribution system

data and results, IEEE Trans. Power Syst. 6 (2) (1991) 813–820.  
doi:10.1109/59.76730.

- [111] European commission smarthg project website.  
URL <http://smarthg.di.uniroma1.it/>
- [112] R. Billinton, W. Li, Reliability Assessment of Electric Power Systems  
Using Monte Carlo Methods, New York, 1994.