

**UCC Library and UCC researchers have made this item openly available.
Please [let us know](#) how this has helped you. Thanks!**

Title	OpenCV2X Mode 4: a simulation extension for cellular vehicular communication networks
Author(s)	McCarthy, Brian; O'Donnell, Aisling
Publication date	2019-09
Original citation	McCarthy, B. and O'Driscoll, A. (2019) 'OpenCV2X Mode 4: A Simulation Extension for Cellular Vehicular Communication Networks', 2019 IEEE 24th International Workshop on Computer Aided Modeling and Design of Communication Links and Networks (CAMAD), Limassol, Cyprus, 11-13 Sept. doi: 10.1109/CAMAD.2019.8858436
Type of publication	Article (peer-reviewed)
Link to publisher's version	https://ieeexplore.ieee.org/document/8858436 http://dx.doi.org/10.1109/CAMAD.2019.8858436 Access to the full text of the published version may require a subscription.
Rights	© 2019 IEEE. Personal use of this material is permitted. Permission from IEEE must be obtained for all other uses, in any current or future media, including reprinting/republishing this material for advertising or promotional purposes, creating new collective works, for resale or redistribution to servers or lists, or reuse of any copyrighted component of this work in other works.
Item downloaded from	http://hdl.handle.net/10468/8802

Downloaded on 2021-06-14T12:27:06Z

OpenCV2X Mode 4

A Simulation Extension for Cellular Vehicular Communication Networks

Brian McCarthy
School of Computer Science
University College Cork Ireland
Cork, Ireland
b.mccarthy@cs.ucc.ie

Aisling O’Driscoll
School of Computer Science
University College Cork Ireland
Cork, Ireland
a.odriscoll@cs.ucc.ie

Abstract—In this work the authors present the first publicly available, open-source simulation model of the Third Generation Partnership Project (3GPP) Release 14 Cellular Vehicle to Everything (C-V2X) standard. The model specifically addresses Mode 4, in which vehicles communicate directly in peer to peer mode using a distributed resource allocation algorithm. Importantly, the model is fully compliant with existing service and application layers already defined by the automotive and standards communities, providing a fully standardised cross-layer communication model spanning application layer based on the ITS-G5 standard to physical layer from the new C-V2X Mode 4 standard. This enables enhancements of the lower layers to support future vehicular use cases. The simulation model has been implemented by extending *SimuLTE*, an OMNeT++ cellular communication stack that enables simulation of LTE networks as well as extending and integrating *Artery*, an ETSI compliant ITS-G5 implementation. The developed model is validated using published 3GPP simulation evaluation scenarios and is available at www.cs.ucc.ie/cv2x.

Index Terms—LTE-V, C-V2X, 3GPP, 4G, Sensing Based Semi-Persistent Scheduling (SB-SPS).

I. INTRODUCTION

Cooperative awareness refers to communication between road users or between road users and infrastructure, where parties are informed of each others location, dynamics and attributes [1]. This awareness forms the basis for “Day 1” Intelligent Transportation System (ITS) applications proposed by ETSI and other standardisation bodies for connected vehicles e.g. active road safety and cooperative traffic efficiency [2].

Until recently, only one vehicular communication standard existed, with geographical variants: ITS-G5 in Europe [3] and WAVE in North America [4], both of which are based on the IEEE 802.11p wireless protocol. However, in the last two years, the 3GPP has specified LTE-V2X, also known as Cellular V2X (C-V2X), a cellular vehicular-specific solution in 3GPP Release 14 [5]. This is a precursor on the path to 5G with potential vehicular use cases further expanded in Release 15 [6], [7]. This 3GPP standard, with support from the 5G Automotive Association (5GAA), has gained significant momentum and claims to overcome many of the drawbacks associated with channel congestion that has prevented 802.11p variants from being mass deployed.

This publication has emanated from research conducted with the financial support of Science Foundation Ireland (SFI) under Grant No: 17/RC-PhD/3479.

Release 14 utilizes a new sidelink radio interface, PC5, for direct V2V communication by building upon the LTE ProSe Device to Device (D2D) Release 12 standard [8]. It further specifies two new communication modes, Mode 3 and Mode 4 as well as two new architectural entities. In Mode 3 (scheduled), the cellular infrastructure allocates and manages the resources necessary for V2V PC5 communications, via the Uu interface. In contrast, in Mode 4 (autonomous) each vehicle selects its radio resources for V2V communications using a distributed scheduling algorithm, the Sensing Based Semi-Persistent Scheduling (SB-SPS). Therefore, in Mode 4 vehicles can operate without infrastructure, analogous to wireless ad-hoc networks. This is considered the baseline mode since safety applications cannot depend on the availability of cellular coverage and is a direct alternative to DSRC/WAVE or ITS-G5.

Since its publication in 2017, a small subset of studies discussed in Section II, have attempted to benchmark C-V2X Mode 4 performance against 802.11p variants as well as to examine the performance of SB-SPS under different environmental conditions and with varying parameterization. However, to the authors knowledge, a freely available, open-source C-V2X Mode 4 model implementation in a well-established, widely used, vehicular simulation package, has not yet been made available. This limits the reproducibility and comparability of prior research as well as the opportunity to explore open C-V2X Mode 4 research challenges related to congestion control and efficiency when dealing with event-triggered traffic. Furthermore, to the authors knowledge, those models described in literature, though not publicly available, do not appear to integrate the C-V2X Mode 4 MAC/PHY layer models with the rest of the communication stack to make it fully compliant with existing automotive standards, up to and including the application layer [9], [10]. Our inclusion of the ITS-G5 standard allows for a more thorough investigation of the performance of CV2X Mode 4 with the current 802.11p standard for vehicular communication. As such, this paper presents a comprehensive open-source C-V2X Mode 4 simulation model that makes a valuable contribution to the wider vehicular communications community.

The rest of this paper is organised as follows: Section II provides a brief overview of the state of the art relating to C-V2X modelling and evaluation. Section III presents the

TABLE I: SCI Format 1 Fields

Priority	Resource Reservation	Frequency Resource location of initial and retransmission	Time gap between initial and Frequency Resource location of initial and retransmission	Modulation and coding scheme	Retransmission index	Reserved information bits
3 bits	4 bits	Calculation based on the number of subchannels	4 bits	5 bits	1 bit	add until 32 bit total

operation of C-V2X Mode 4 with Section IV describing the presented model. Sections V and VI describe the simulation environment and parameters used to validate the model along with results investigating the impact of SB-SPS parameterization.

II. RELATED WORK

Since its publication in 2017, C-V2X Mode 4 has been reviewed in the literature [11]–[13] and some tentative performance studies have been undertaken [14]–[17] either evaluating C-V2X Mode 4 performance against 802.11p or examining the impact of specific SB-SPS parameters. These studies, however, implement their own bespoke models that are not freely available to the community using a variety of simulation environments from ns-3 to OMNeT++ to MatLab. Furthermore, to the best of the authors knowledge, most of these studies [9], [10], [18] only consider the link-layer simulation of C-V2X Mode 4 and do not provide a fully standards-compliant cross-layer stack integrating non-IP with the existing LTE stack or complying with existing automotive and standardized application and facilities layers e.g. ETSI or SAE.

The credibility of scientific publications is often discussed in the context of Open Science, within which Open Source is an important pillar. In this area, the vehicular communications community has made enormous progress during the last decade, with the most popular network simulators released under an open-source license [19], [20]. With these simulators, a common set of vehicular simulation models are available that are wide-spread and well-validated. This is beneficial as it provides a common platform upon which results can be compared and benchmarked. It is intended that the model presented in this paper will provide such a basis for C-V2X Mode 4 studies.

III. C-V2X MODE 4 - HOW IT WORKS

C-V2X Mode 4, as specified by the 3GPP, employs a sensing-based semi-persistent scheduling algorithm for resource allocation at its MAC and PHY layers. This process can be broken into distinct phases of Selection & Sensing, and Transmission, with further explanation available in [10], [14], [21]. However, it is first necessary to understand how the channel is structured and the existence of scheduling control information.

A. Channelisation & Scheduling Information

Based on the OFDM physical layer of LTE, the C-V2X Mode 4 channel is divided in both time and frequency. In the time domain the channel is broken into a frame of 10ms with the frame further subdivided into sub-frames of 1ms in length. Within the frequency domain, each channel is divided into sub-channels, which are made up of Resource Blocks

(RBs). The number of sub-channels per sub-frame and the size of sub-channels with respect to the number of RBs are configurable but are constrained by the total allocated spectrum.

The channel is also broken into Physical Sidelink Control Channel (PSCCH) and the Physical Sidelink Shared Channel (PSSCH), comprised of RBs. The PSSCH transmits application layer/data packets, known as Transport Blocks (TBs). The PSCCH is used to transmit scheduling control information known as Sidelink Control Information (SCIs). The PSCCH and PSSCH can both have individual sections of bandwidth dedicated to them (non-adjacent mode), or they can share the whole bandwidth interchangeably (adjacent mode). The structure of SCI Format 1 is illustrated in Table I. SCI Format 1 indicates the priority of the packet (denoted by Priority field), the time period of the intended next use of the resource (Resource Reservation field), the number and location of the resources for the initial transmission and re-transmission, the re-transmission time (Time gap between initial transmission and the re-transmission), the modulation and coding scheme (MCS) and, finally, whether or not a re-transmission will occur (Re-transmission index field). An SCI is sent in the same timeslot as a TB and occupies 2 RBs. A TB cannot be decoded if the associated SCI is not received due to the MCS being specified within the SCI.

B. Selection & Sensing - MAC & PHY Layer

On reception of an upper layer packet, the MAC layer begins the process of reserving resources for a recurrent period known as a scheduling grant. It does this by specifying the number of sub-channels it requires, the periodicity of the transmission called *Resource Reservation Interval (RRI)* and a counter for how long to maintain the reservation.

This information is passed to the PHY layer which is tasked with selecting *Candidate Single-Subframe Resources (CSRs)*, which are a single or series of sub-channel(s) that match the parameters specified by the MAC layer. The PHY layer uses the sensed information based on previously received SCIs and TBs to filter resources that are likely to be utilised as well as those reserved with lower priorities. It then returns to the MAC layer 20% of the best possible CSRs based on those available and those with lowest Received Signal Strength Indicator (RSSI).

C. Transmission

When a TB is ready to be transmitted, the MAC layer must determine the MCS to use. An MCS is selected among the configured range, e.g. should the highest MCS not be able to accommodate the resource then the resource is relinquished and re-selection of a new resource must occur. The TB is then sent to the PHY layer with the necessary information to create an SCI message, with the

PHY layer subsequently sending both the TB and SCI message in the same subframe. At the MAC layer, the counter for maintaining the reservation is decremented. If the counter is reduced to 1, the MAC layer attempts to maintain the reservation. This is done with probability $P(X > probResourceKeep)$ with $probResourceKeep \in [0, 0.8]$, otherwise the resource is relinquished. If the resource is relinquished then upon transmission of the final TB the SCI informs other users that the resource is available.

IV. C-V2X MODE 4 MODEL IMPLEMENTATION

The 3GPP expects C-V2X to leverage Cooperative Awareness Messages (CAM) and Decentralized Environmental Notification Messages (DENM) as specified in [22] to reuse existing upper layer standards. CAM messages are designed to create and maintain awareness of other vehicles in the vicinity and to support cooperation among vehicles using the road network [1]. In contrast, DENM messages are used as an alert service for other vehicles to learn of changes in the road network [23]. The architecture of the developed C-V2X Mode 4 model is shown in Fig. 1. Our implementation leverages the *Artery* [24] framework. This framework integrates the *OMNeT++* network simulator and the *SUMO* road traffic simulator and also incorporates the *Vanetza* framework, which provides the implementation of the ETSI ITS-G5 standard. For the lower layers, the implemented model extends *SimuLTE* [25], which is used for the simulation of LTE based cellular networks. It has been modified with a new PHY and MAC layer implementing the core Mode 4 aspects, as well as a non-IP abstraction layer to deal with Artery modelled traffic. This is represented by the red sections in Fig. 1 and all layers have been modified for the new paradigm of non-IP traffic as well as the fact that an eNodeB may not exist in the simulation. This is represented by the grey sections in Fig. 1.

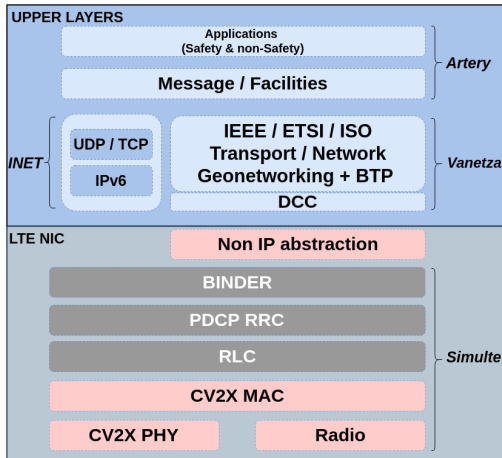

Fig. 1: OMNeT++ C-V2X Mode 4 Architecture

A. Upper Layer Integration

To allow for the integration of *Artery* and *SimuLTE*, a new *radio driver*, Network Interface Card (*NIC*) and Vehicle type were implemented. The radio driver *Mode4RadioDriver* allows for *Artery* non-IP traffic to be translated into a packet that is consumable by the PDCP RRC layer of *SimuLTE*.

This is captured as the Non-IP abstraction in the Mode 4 architecture diagram in Fig 1. Furthermore *Artery request* calls were modified to allow for the message lifetime to be passed to the *NIC*, which informs the maximum latency parameter T_2 in SB-SPS, which determines the maximum time into the future that PHY layer can search for possible CSRs.

B. MAC & PHY Layer

As an eNB is not present, the MAC layer must generate its scheduling grant (see Section III-B), based on preconfigured SB-SPS parameters and communication with the PHY layer. This is implemented in *LteMacVueMode4*, which modifies the *LteMacUeD2D* class provided by *SimuLTE*. *LteMacUeD2D* implements the release 12 version of D2D communication [26]. As this is based on the use of an eNB for scheduling it was removed and the logic for generating grants added to the MAC layer. As shown in Fig. 2, upon receiving a *newDataPkt* message from the RLC layer, the MAC layer either triggers the generation of a *SchedulingGrant*, which involves determining the resources based on pre-configured parameters and contacting the PHY layer or if a grant is available it schedules sending of the received packet. This is shown in Fig. 2. When a TB is unavailable at the time of transmission the MAC layer will send an SCI request but no MAC PDU to the PHY layer. The PHY layer will in turn broadcast an SCI with no associated TB.

The PHY layer comprises the bulk of the implementation of SB-SPS. *LtePhyVueMode4* is based on the *LtePhyUeD2D* class provided by *SimuLTE*, but has been extended to implement the SB-SPS structures. This includes the *sensing window* which maintains the history of SCIs and TBs, how CSRs are determined and filtered along with recording and reporting of Channel Busy Ratio (CBR) measuring channel congestion. In addition, the PHY is also where the implementation of SCI messages resides including the means to generate and decode them.

Notably, to comply with 3GPP detailed simulation guidelines [22], the WINNER+ B1 LOS channel model and Nakagami Fading have been implemented within *SimuLTE*. Furthermore, new NIST Block Error Rate (BLER) curves based on MCS have been integrated with *SimuLTE* [27]. This was due to *SimuLTE* using *Channel Quality Information* (CQI) for determining the BLER of received packets and the correct MCS to use for a transmission, but in CV2X Mode 4, MCS is determined without taking into account the CQI.

The communication exchanges between the C-V2X SB-SPS MAC and PHY layers can be largely categorized as follows:

- CBR reporting: The PHY layer reports CBR after every sub-frame. This is shown in Fig. 2 as the CBR Report message.
- CSR requests: The MAC layer requests a set of CSRs from the PHY layer and following filtering, the PHY layer sends back the best 20% of CSRs.
- Data request: The MAC layer sends TB to the PHY layer or the PHY layer sends an incoming received packet to the MAC layer.

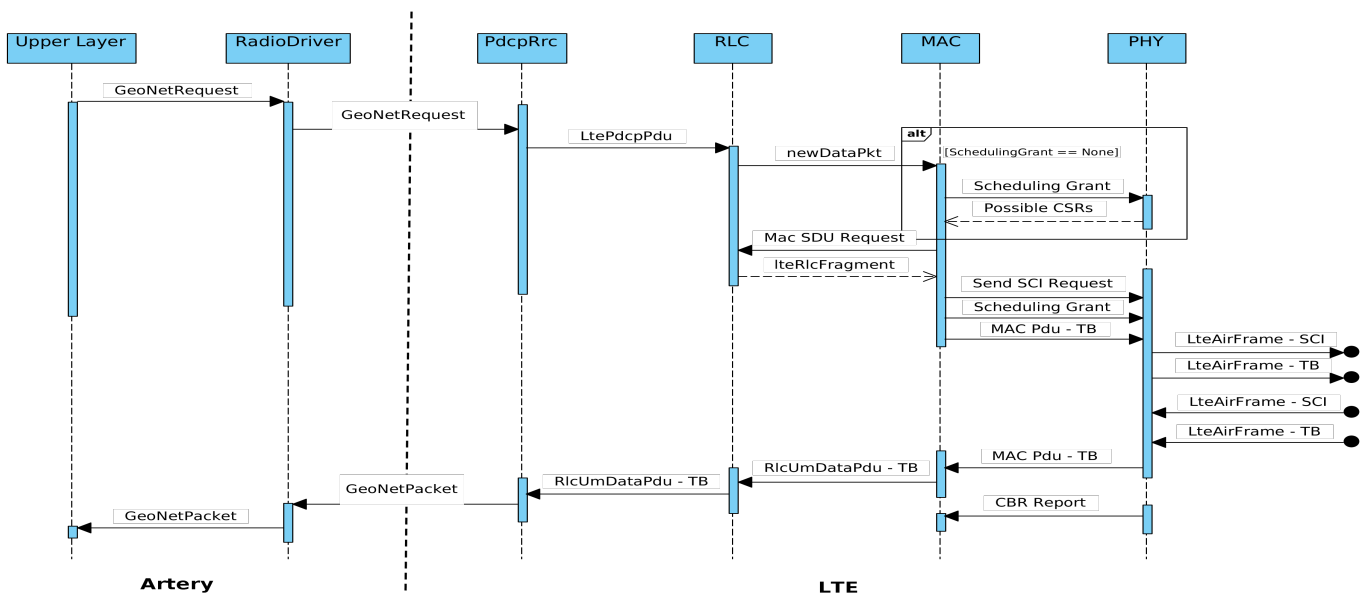

Fig. 2: Sequence Diagram of message exchange in OpenCV2X

- SCI request: The MAC layer can request the PHY layer to send an SCI message with a configured sidelink grant.

When a TB is unavailable at the time of transmission the MAC layer will send an SCI request but no MAC PDU to the PHY layer. The PHY layer will in turn broadcast an SCI with no associated TB.

C. SimuLTE Architecture Integration

As part of the integration of Mode 4, numerous other modifications were made to the *SimuLTE* stack. One of the main changes is that the *Binder* and *Deployer* modules now exist outside of an eNB. The Binder is an important concept in *SimuLTE* used primarily to manage the UEs in the simulation and is accessed by UEs when determining interference. The Deployer manages the deployment of the UEs and maintains their position in the simulation. In traditional LTE, these two modules were integrated into the eNodeB only as autonomous UE resource selection is not considered. As both modules are core to *SimuLTE* function they needed to be deployed independently of the eNodeB for Mode 4 to work successfully. This change allows for simulations to be run without the need for an eNodeB to exist.

A further significant change was the required integration of non-IP based traffic. This led to minor changes throughout the entire communication stack to allow for non-IP traffic flows as well as changes to the Binder, which maintained the information for all UEs based on their IPv4 address. This change was driven by the integration of *Artery*, which has traffic which is not IPv4 based, while *SimuLTE* has a dependency on IPv4 in the current version.

V. SIMULATION RESULTS

In accordance with the 3GPP simulation guidelines [22], we evaluate our model implementation with respect to a highway scenario, considering fast vehicular speeds of 140 km/h. The highway is a 2700m in length comprising 6 lanes, 3 in either

direction with a lane width of 4 metres. The inter-vehicle distance is $2.5s * \text{maximum speed}$. The scenario maintains 200 vehicles in the simulation at its most dense stage. This scenario is referred to as Highway Fast in subsequent results. We further evaluate the impact of vehicular traffic density on Packet Delivery Rate (PDR) in a scenario labelled Highway Slow, where maximum vehicle speed is 70 km/h. This results in a greater vehicle density of 380 vehicles at its most dense stage. As outlined in Section IV-B, the WINNER+ B1 LOS channel model, Nakagami fast fading and correlated log-normal shadowing are considered. 30 iterations of every experiment are run. The results exhibited very little variance with 95% confidence intervals within 2% and as a result are not shown. Each experiment utilised a random seed impacting the random elements of the SB-SPS algorithm such as what resources are selected as well as the length for which a grant is maintained.

TABLE II: Simulation Configuration Parameters

SB-SPS Parameters	Value
pStep	100
Number of Subchannels	3
Subchannel Size	16
MCS	5 & 7
probResourceKeep	0.4
RSRP Threshold	-128 dBm
Message Tx Rate	10 Hz
Adjacent/Non-adjacent PSCCH, PSSCH	Adjacent
Transmission Power	23 dBm
Bandwidth	10 MHz
Carrier Frequency	5.9 GHz
Noise Figure	9 dBm
Antenna Gain	3 dBi
Shadowing	Log-normal
Standard Deviation	3 dB
Decorrelation Distance	25m
Nakagami Shape Factor	1.1

Table II describes the SB-SPS simulation parameters used. The application layer traffic comprises two message sizes; a 300 Byte packet which is sent every 5th message and a 190

Byte packet which is sent in sequences of 4.

The impact of SB-SPS parameters such as $pStep$ and $probResourceKeep$ are investigated as shown in Fig. 3 and Fig. 4 respectively. $pStep$ determines the *sensing window length* in ms denoted as swl with $probResourceKeep$ determining the probability of the Vehicular User Equipment (VUE) to maintain the existing scheduled grant.

It is evident from Fig. 3 that the default *sensing window length* of 1000ms performs best. This is to be expected as a result of having more historical information available upon which to base the CSR selection process. Reducing the *sensing window length* has a relatively minimal impact however this will be further deteriorated if *RRIs* of varying duration are considered e.g. if a *sensing window* of 100ms is used and another VUE chooses an *RRI* of 200ms, then the reservation would not be recorded in the *sensing window* and may potentially cause a collision.

In Fig. 4, the impact of $probResourceKeep$ is minimal. A $probResourceKeep = 0$ results in an increased likelihood of a VUE maintaining the same reservation, with $probResourceKeep = 0.8$ representing the least likelihood of maintaining a reservation. Both of these have drawbacks as shown in Fig. 4. Given a $probResourceKeep = 0$ and a scenario where a VUE chooses the same reservation as another VUE, both are likely to maintain that same reservation repeatedly with collisions continually occurring. Conversely, with a $probResourceKeep = 0.8$, a VUE is likely to have to regularly reserve new resources, increasing the probability of selecting the same resources as another VUE. As a result, it can be noted in Fig. 4 that values of $probResourceKeep = 0.2$, $probResourceKeep = 0.4$, $probResourceKeep = 0.6$ perform the best in this simulated scenario.

Fig. 5 is inspired by the analysis conducted by Molina et al examining the causation of packet loss [16]. We evaluate packet loss as a function of distance between the transmitter and receiver. Predictably, as the distance increases between the transmitter and receiver, the primary cause of packet loss is due to increased propagation loss attributed to path loss and fading. However it can be noted that at smaller distances, packet loss is mainly attributed interference caused by collisions. Collisions occur as a consequence of the hidden node problem where vehicles cannot sense one another, but also when vehicles simultaneously select the same resources as well as vehicles intentionally selecting reserved resources because they have higher priority.

Finally, Fig. 6 shows the impact of different vehicular traffic densities on the performance of CV2X Mode 4. Increased vehicular density has an impact on the PDR with an increased number of channel collisions. The highway slow scenario represents a medium density scenario according to the 3GPP standard. This highlights the need for comprehensive congestion control mechanisms for increased reliability in higher density scenarios.

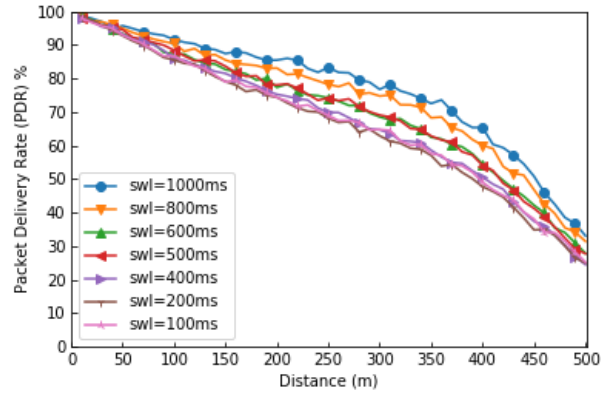

Fig. 3: Effect of *Sensing Window* on PDR (Highway Fast)

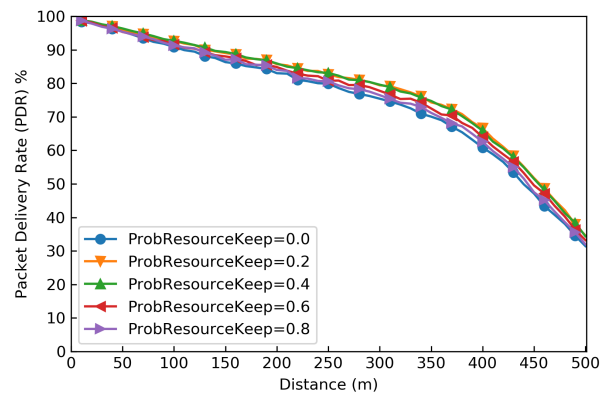

Fig. 4: Effect of $probResourceKeep$ on PDR (Highway Fast)

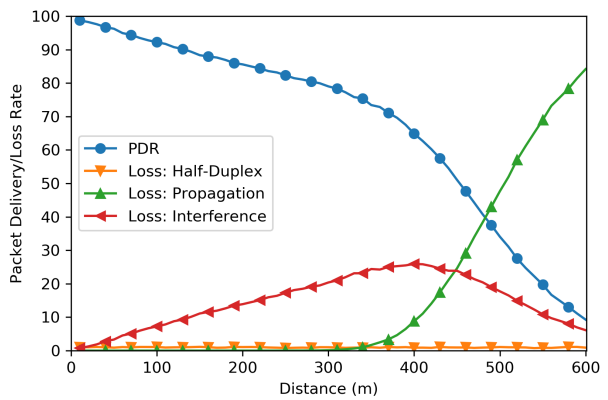

Fig. 5: PDR & Causation of Packet Loss (Highway Fast)

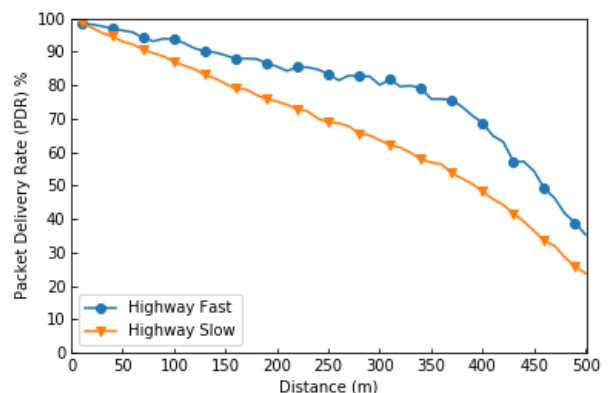

Fig. 6: Effect of traffic density on PDR

VI. CONCLUSION

In this paper, a freely available, open-source implementation of the 3GPP Release 14 C-V2X Mode 4 standard is presented. This is a modification and extension of the *SimuLTE* and *Artery* packages in the well-known OMNeT++ network simulator. The inclusion of the current ITS-G5 standard will enable a more robust investigation of the standard especially against the current standard technologies such as 802.11p. Future work will conduct a thorough parameter study, discussing the impacts of each parameter on the SB-SPS performance. It will further examine congestion control mechanisms such as MCS adaptation and packet dropping as well as evaluating the performance of the DCC mechanism defined in ITS-G5. Finally, an investigation of the performance of C-V2X for non-periodic application traffic is warranted as both CAM and DENM messages are event triggered, which is counter intuitive to the scheduled nature of SB-SPS when determining resource allocations. We believe this model will be of great value to the wider vehicular communications community and will expedite future advancements of the technology allowing for comparable performance evaluations between research studies.

ACKNOWLEDGMENT

The authors would like to thank Prof. Dirk Pesch and Dr. Md. Noor-A.-Rahim for their insightful discussions.

REFERENCES

- [1] *Intelligent Transport Systems (ITS); Vehicular Communications; Basic Set of Applications; Part 2: Specification of Cooperative Awareness Basic Service*, ETSI, Sept 2014, eTSI EN 302 637-2 V1.3.1.
- [2] E. C. Innovation and N. E. A. (INEA), "Blending ITS," https://ec.europa.eu/inea/sites/inea/files/2017_blending_its.pdf, accessed 11th May 2019.
- [3] *Intelligent Transport Systems (ITS); Communications Architecture*, ETSI, Sept 2010, eTSI EN 302 665 V1.1.1. pages xiv, 3, 21, 24, 25..
- [4] D. Jiang, V. Taliwal, A. Meier, W. Holfelder, and R. Herrtwich, "Design of 5.9 ghz dsrc-based vehicular safety communication," *IEEE Wireless Communications*, vol. 13, no. 5, pp. 36–43, October 2006.
- [5] *Evolved Universal Terrestrial Radio Access (E-UTRA) and Evolved Universal Terrestrial Radio Access Network (E-UTRAN) Overall Description Stage 2, V14.7.0*, 3GPP, June 2018, 3GPP TS 36.300.
- [6] *Study on enhancement of 3GPP Support for 5G V2X Services, V15.2.0*, 3GPP, June 2018, 3GPP 5G, ETSI TR 22 886.
- [7] *Service Requirements for enhanced V2X Scenarios, V15.3.0*, 3GPP, July 2018, 3GPP 5G, ETSI TS 122 186.
- [8] *Proximity-based services (ProSe); Stage 2, Vx14.1.0*, 3GPP, Mar 2017, 3GPP TS 23 303.
- [9] G. Cecchini, A. Bazzi, B. M. Masini, and A. Zanella, "Lte-v2sim: An lte-v2v simulator for the investigation of resource allocation for cooperative awareness," in *2017 5th IEEE International Conference on Models and Technologies for Intelligent Transportation Systems (MT-ITS)*, June 2017, pp. 80–85.
- [10] R. Molina-Masegosa and J. Gozalvez, "Lte-v for sidelink 5g v2x vehicular communications: A new 5g technology for short-range vehicle-to-everything communications," *IEEE Vehicular Technology Magazine*, vol. 12, no. 4, pp. 30–39, Dec 2017.
- [11] M. Boban, A. Kousaridas, K. Manolakis, J. Eichinger, and W. Xu, "Connected roads of the future: Use cases, requirements, and design considerations for vehicle-to-everything communications," *IEEE Vehicular Technology Magazine*, vol. 13, no. 3, pp. 110–123, Sep. 2018.
- [12] S. Chen, J.-L. Hu, Y. Shi, Y. Peng, J.-Y. Fang, R. Zhao, and L. Zhao, "Vehicle-to-everything (v2x) services supported by lte-based systems and 5g," *IEEE Communications Standards Magazine*, vol. 1, pp. 70–76, July 2017.
- [13] S. Husain, A. Kunz, A. Prasad, K. Samdanis, and J. Song, "An overview of standardization efforts for enabling vehicular-to-everything services," in *2017 IEEE Conference on Standards for Communications and Networking (CSCN)*, Sept 2017, pp. 109–114.
- [14] A. Nabil, V. Marojevic, K. Kaur, and C. B. Dietrich, "Performance analysis of sensing-based semi-persistent scheduling in C-V2X networks," *CoRR*, vol. abs/1804.10788, Apr 2018. [Online]. Available: <http://arxiv.org/abs/1804.10788>
- [15] A. Mansouri, V. Martinez, and J. Härrri, "A first investigation of congestion control for LTE-V2X mode 4," in *WONS 2019, 15th IEEE Wireless On-demand Network systems and Services Conference, 22-24 January 2019, Wengen, Switzerland, Wengen, SWITZERLAND*, Jan 2019. [Online]. Available: <http://www.eurecom.fr/publication/5791>
- [16] R. Molina-Masegosa and J. Gozalvez, "System level evaluation of lte-v2v mode 4 communications and its distributed scheduling," *IEEE 85th Vehicular Technology Conference (VTC Spring)*, pp. 1–5, June 2017.
- [17] A. Bazzi, G. Cecchini, B. M. Masini, and A. Zanella, "Study of the impact of PHY and MAC parameters in 3gpp C-V2V mode 4," *CoRR*, vol. abs/1807.10699, July 2018. [Online]. Available: <http://arxiv.org/abs/1807.10699>
- [18] D. Wang, R. R. Sattiraju, A. Weinand, and H. D. Schotten, "System-level simulator of LTE sidelink C-V2X communication for 5g," *CoRR*, vol. abs/1904.07962, Apr 2019. [Online]. Available: <http://arxiv.org/abs/1904.07962>
- [19] C. Sommer, J. Härrri, F. Hrizi, B. Schünemann, and F. Dressler, *Simulation Tools and Techniques for Vehicular Communications and Applications*. Book Chapter N°11 in "Vehicular Ad Hoc Networks: Standards, Solutions and Research", Antonella Molinaro, Claudia Campoli, Riccardo Scopigno Eds, 2015; ISBN: 9783319154961, May 2015. [Online]. Available: <http://www.eurecom.fr/publication/4498>
- [20] S. Joerer, C. Sommer, and F. Dressler, "Toward reproducibility and comparability of ivc simulation studies: a literature survey," *IEEE Communications Magazine*, vol. 50, no. 10, pp. 82–88, October 2012.
- [21] B. Toghi, M. Saifuddin, H. N. Mahjoub, M. O. Mughal, Y. P. Fallah, J. Rao, and S. Das, "Multiple access in cellular v2x: Performance analysis in highly congested vehicular networks," in *2018 IEEE Vehicular Networking Conference (VNC)*, Dec 2018, pp. 1–8.
- [22] *Study on LTE-based V2X services (v14.0.0, Release 14)*, 3GPP, July 2016, 3GPP TR 36.885.
- [23] *Intelligent Transport Systems (ITS); Vehicular Communications; Basic Set of Applications; Part 3: Specifications of Decentralized Environmental Notification Basic Service*, ETSI, Nov 2014, eTSI EN 302 637-3 V1.2.2.
- [24] R. Riebl, H. Gunther, C. Facchi, and L. C. Wolf, "Artery: Extending veins for VANET applications," in *2015 International Conference on Models and Technologies for Intelligent Transportation Systems (MT-ITS), Budapest, Hungary, June 3-5, 2015*, 2015, pp. 450–456. [Online]. Available: <https://doi.org/10.1109/MTITS.2015.7223293>
- [25] A. Virdis, G. Stea, and G. Nardini, "Simulating lte/lte-advanced networks with simulte," in *Simulation and Modeling Methodologies, Technologies and Applications*, M. S. Obaidat, T. Ören, J. Kacprzyk, and J. Filipe, Eds. Cham: Springer International Publishing, Jan 2016, pp. 83–105.
- [26] G. Nardini, A. Virdis, and G. Stea, "Simulating device-to-device communications in omnet++ with simulte: scenarios and configurations," *CoRR*, vol. abs/1609.05173, Sept 2016. [Online]. Available: <http://arxiv.org/abs/1609.05173>
- [27] R. R. Jian Wang, *BLER Performance Evaluation of LTE Device-to-Device Communications*, Nov 2016, wireless Networks Division Communications Technology Laboratory (NIST).