

Title	Creation of a complex butterfly attractor using a novel Lorenz-type system
Authors	Elwakil, Ahmed S.;Özoğuz, Serdar;Kennedy, Michael Peter
Publication date	2002-04
Original Citation	Elwakil, A.S., Ozoguz, S., Kennedy, M.P., 2002. Creation of a complex butterfly attractor using a novel Lorenz-Type system. IEEE Transactions on Circuits and Systems I: Fundamental Theory and Applications , 49(4), pp.527-530. doi: 10.1109/81.995671
Type of publication	Article (peer-reviewed)
Link to publisher's version	10.1109/81.995671
Rights	©2002 IEEE. Personal use of this material is permitted. However, permission to reprint/republish this material for advertising or promotional purposes or for creating new collective works for resale or redistribution to servers or lists, or to reuse any copyrighted component of this work in other works must be obtained from the IEEE.
Download date	2023-09-27 17:43:20
Item downloaded from	<a href="https://hdl.handle.net/10468/162">https://hdl.handle.net/10468/162</a>



# UCC

**University College Cork, Ireland**  
 Coláiste na hOllscoile Corcaigh

## Creation of a Complex Butterfly Attractor Using a Novel Lorenz-Type System

A. S. Elwakil, S. Özoğuz, and M. P. Kennedy

**Abstract**—A novel Lorenz-type system of nonlinear differential equations is proposed. Unlike the original Lorenz system, where the chaotic dynamics remain confined to the positive half-space with respect to the  $Z$  state variable due to a limiting threshold effect, the proposed system enables bipolar swing of this state variable. In addition, the classical set of parameters  $(\alpha, b, c)$  controlling the behavior of the Lorenz system are reduced to a single parameter, namely  $a$ . Two possible modes of operation are admitted by the system; switching between these two modes results in the creation of a complex butterfly chaotic attractor. Numerical simulations and results from an experimental setup are presented.

**Index Terms**—Chaos, chaotic oscillators, Lorenz system.

### I. INTRODUCTION

The classical Lorenz system is described by [1]

$$\dot{X} = a(Y - X) \tag{1a}$$

$$\dot{Y} = (b - Z)X - Y \tag{1b}$$

$$\dot{Z} = XY - cZ \tag{1c}$$

where  $a, b,$  and  $c$  are constants and the two multiplier-type nonlinearities ( $XY$  and  $XZ$ ) are responsible for the generation of chaos. The projection of the chaotic attractor observed from this system in the  $X - Z$  plane is widely-known as the butterfly attractor. The dynamics of the above equations have been studied in detail by several researchers (see for example [2]) and have been recently revisited in [3] and [4], where new sets of equations (Chen’s system), not topologically equivalent to the original system, have been proposed. Nevertheless, these new sets also rely on multiplier-type nonlinearities. Due to some unique features of butterfly chaos, attempts have been made to utilize it as a core engine for a number of chaos-based applications [5], [6].

In [7] and [8], attempts to remove the two multipliers from this system were reported. It was particularly shown in [8] that the contribution to the chaotic dynamics of multiplying any two state variables can be emulated via a bipolar voltage-controlled switching constant. The resulting system is also not topologically equivalent to the Lorenz system, but of similar qualitative dynamics. On arriving to this system, the procedure followed in [8] stressed the fact that the butterfly attractor should lie only in the positive half-space with respect to the  $Z$  state variable, similar to the situation in the original Lorenz system, and indeed in the systems of [3], [4] and [7]. This constraint is inherited from (1b) due to the positive threshold  $b$ . Simply removing  $b$  from (1b) is not possible.

In this short brief, a novel Lorenz-type system, which is free from the positive  $Z$  constraint, is proposed. Not only has the threshold constant  $b$  been removed from (1), but also the damping constant  $c$ . Hence, the system is controlled via the remaining single parameter  $a$ . The proposed system acquires two possible modes of operation; the switching

Manuscript received May 13, 2001; revised November 6, 2001. This paper was recommended by Associate Editor C. K. Tse.

A. S. Elwakil is with the Department of Electronic & Computer Engineering, University of Sharjah, U.A.E (e-mail:elwakil@ee.ucd.ie).

S. Özoğuz is with the Istanbul Technical University, Faculty of Electrical-Electronics Engineering, Maslak, Istanbul 80626, Turkey.

M. P. Kennedy is with the Department of Microelectronic Engineering, University College Cork, Cork, Ireland.

Publisher Item Identifier S 1057-7122(02)03120-3.

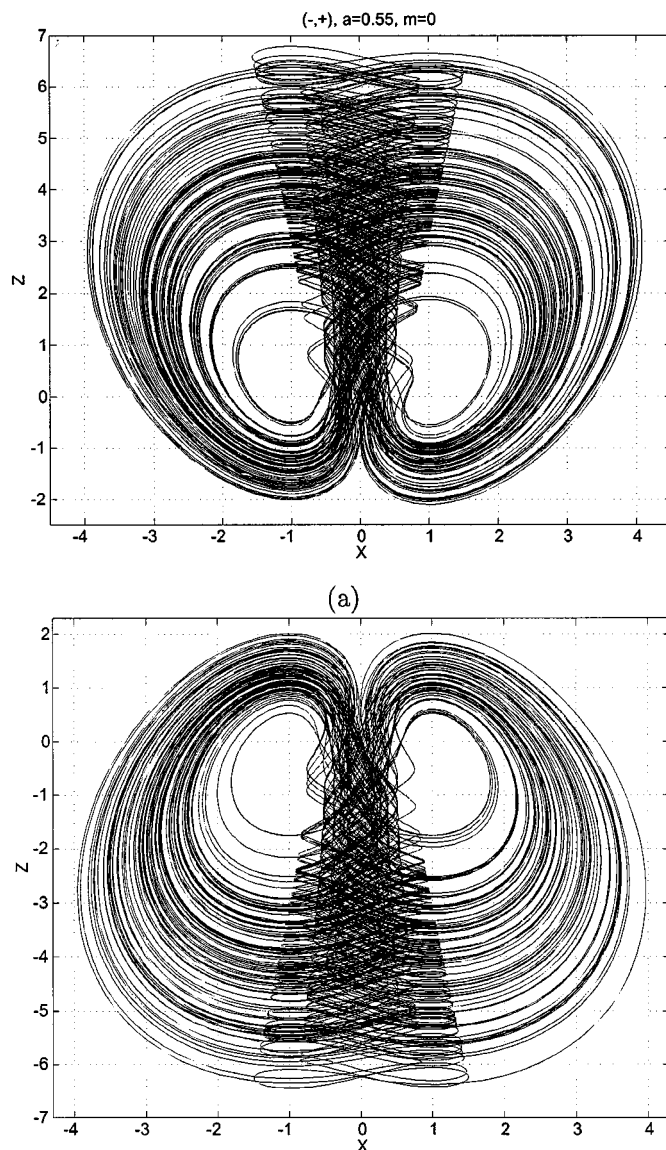

Fig. 1. Two-wing butterfly chaotic attractors obtained via numerical integration of (2) with  $a = 0.55$ : (a)  $S(-, +)$  mode and (b)  $S(+, -)$  mode.

action between these two modes creates a complex (*four-wing*) butterfly attractor. We validate our proposals via numerical simulations and by constructing an experimental electronic circuit.

### II. PROPOSED SYSTEM

The following set of differential equations are proposed:

$$\dot{X} = a(Y - X) \tag{2a}$$

$$\dot{Y}_{\mp} = \mp K Z \tag{2b}$$

$$\dot{Z}_{\pm} = \pm |X| \mp 1 \tag{2c}$$

and

$$K = \begin{cases} 1, & X \geq 0 \\ -1, & X < 0 \end{cases} \tag{2d}$$

Here, the required range for  $a$  is  $0 < a < 1$ . As compared to (1), note that the multiplier  $XY$  has been replaced with the absolute value function  $|X|$  and that  $K$  is effectively equal to  $\text{sgn}(X)$ .

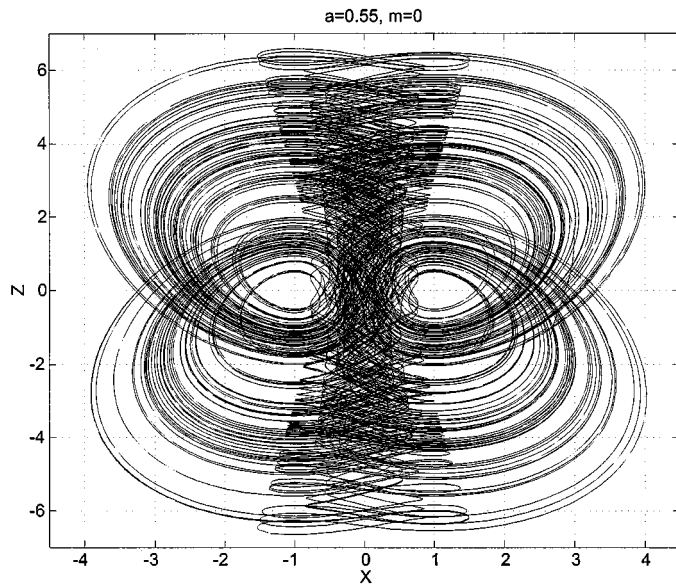

Fig. 2. Complex (*four-wing*) butterfly attractor ( $a = 0.55$  and  $T_F = 250T_S$ ).

The system described by (2) is a dual system with two complementary modes of operation. The first mode, in which  $\dot{Y} = \dot{Y}_-$  and  $\dot{Z} = \dot{Z}_+$  is denoted  $S(-, +)$  while the second mode, where  $\dot{Y} = \dot{Y}_+$  and  $\dot{Z} = \dot{Z}_-$ , is denoted  $S(+, -)$ . It is clear from (2) that there are two equilibrium points for this system given by  $(x_0, y_0, z_0) = (\pm 1, \pm 1, 0)$ . Note that  $|x_0| = 1$  and hence from (2c)  $\dot{Z}|_{X=x_0} = 0$ . Therefore, the threshold effect performed by  $b$  in (1b) is now performed by  $|X|$  in (2c). In particular, and considering the  $S(-, +)$  mode, for  $|X| < 1$ ,  $Z$  switches to the negative half-space while for  $|X| > 1$ ,  $Z$  switches to the positive-half space. Therefore, unlike (1b), where it is not the sign of  $Z$  but the sign of  $(b - Z)$  which changes at the threshold, (2c) guarantees a change of the sign of  $Z$ , ultimately removing the constraint inherited from the Lorenz system. In conclusion, the thresholding effect has been incorporated into one of the nonlinearities of the system (2).

To highlight the mechanism by which the proposed system functions, consider the  $S(-, +)$  mode in the range  $0 < X < 1$  under steady-state conditions. In this case  $\dot{Z}$  is negative while  $\dot{Y}$  is positive. Recalling (2a), it is clear that  $Y$  will eventually exceed  $X$  changing the sign of  $\dot{X}$  from negative to positive. Consequently,  $X$  will grow to hit the threshold value  $X = 1$  and exit to the range  $X > 1$ . When this happens,  $\dot{Z}$  will become positive and hence  $\dot{Y}$  becomes negative. Thus,  $Y$  will start to decrease until it is less than  $X$  turning  $\dot{X}$  back negative and forcing  $X$  to re-enter the range  $0 < X < 1$ . Similar action takes place in the negative  $X$  half-space and in the dual system  $S(+, -)$ . This alternating sign change mechanism provides necessary stretching and folding to generate chaos. Note that such mechanism is not possible in the systems  $S(+, +)$  or  $S(-, -)$  where  $X$  and  $Y$  decay with time while  $Z$  diverges unbounded.

In Fig. 1(a) and (b), projections of the butterfly attractor in the  $X - Z$  plane are shown for the two modes  $S(-, +)$  and  $S(+, -)$  respectively. Here,  $a$  was set to 0.55. The characteristic equation of the system in both modes is identical and given by:  $\lambda^3 + a\lambda^2 - aK^2 = 0$ . The set of eigenvalues corresponding to Fig. 1 are thus  $(-1.05, 0.25 \pm j0.6795)$  at both equilibrium points. Since the eigenvalue pattern is independent of the mode in which the system operates, this suggests that one can utilize an external source to force switching to occur between  $S(-, +)$  and  $S(+, -)$ . The result in this case is the complex (*four-wing*) butterfly attractor shown in Fig. 2. Here, a pulse train with period  $T_F = 250T_S$ , where  $T_S$  is the normalized time constant of (2) (here,  $T_S = 1$ ),

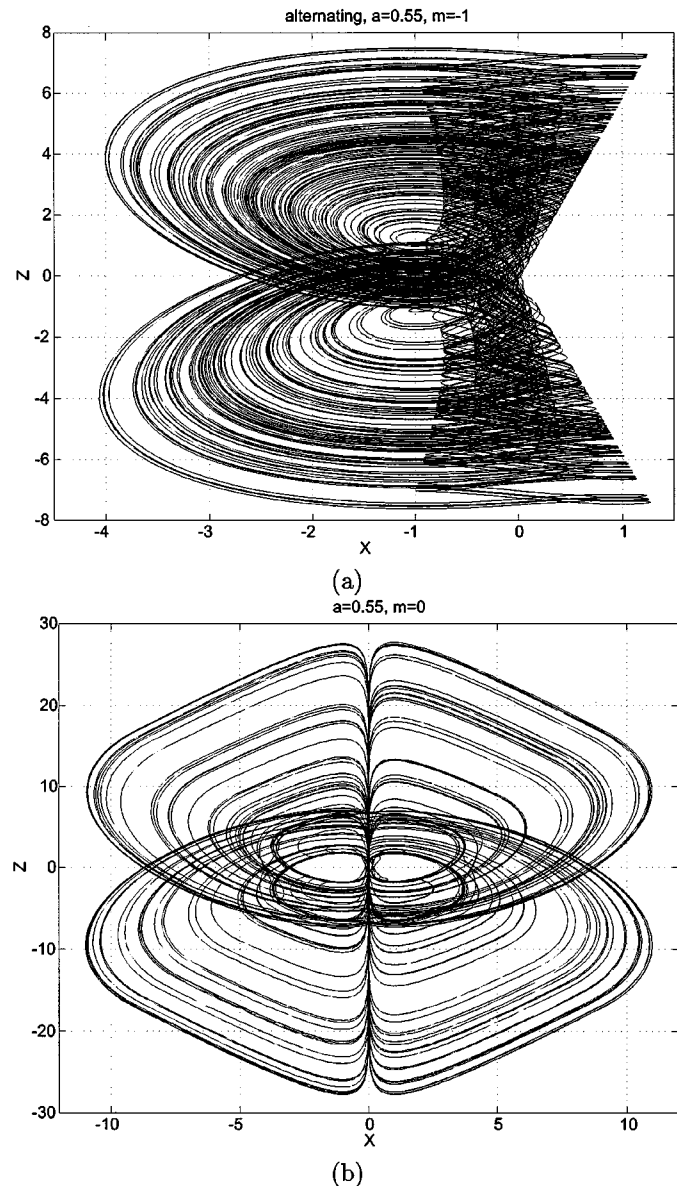

Fig. 3. Observations from altered versions of (2): (a)  $Z$ -symmetrical left-half two-wing attractor and (b) complex four-wing with  $K = \text{sgn}(Y)$  instead of  $K = \text{sgn}(X)$ .

was used to force the switching. The condition  $T_F \gg T_S$  should hold in order to allow the system to spend sufficient time in one mode before switching to the other. If one considers the pulse train as a sequence of binary data, then the one's and zero's will be encrypted by the  $S(-, +)$  and  $S(+, -)$  modes, respectively.

It is clear that the complex four-wing attractor is symmetrical with respect to  $X = 0$  and  $Z = 0$  while the two-wing attractors of Fig. 1 are symmetrical with respect to  $X = 0$ . Thus, one asks if it is possible to obtain two-wing attractors which are symmetrical with respect to  $Z = 0$ . The answer to this question is affirmative, as shown in Fig. 3(a), which represents a two-wing attractor corresponding to the left-half of the four-wing attractor in Fig. 2. To obtain these  $Z$ -symmetrical dynamics, (2b) has to be modified to read:  $\dot{Y}_{\mp} = \mp KZ + m$ , where  $m$  is a constant. The case  $m = 0$  enables us to observe the full complex attractor while the case  $m = -1$  enables us to observe only its two-wing left-half (see Fig. 3(a)). With  $m = 1$ , the mirror image of Fig. 3(a) around  $X = 0$  is obtained corresponding to the right-half two-wing attractor.

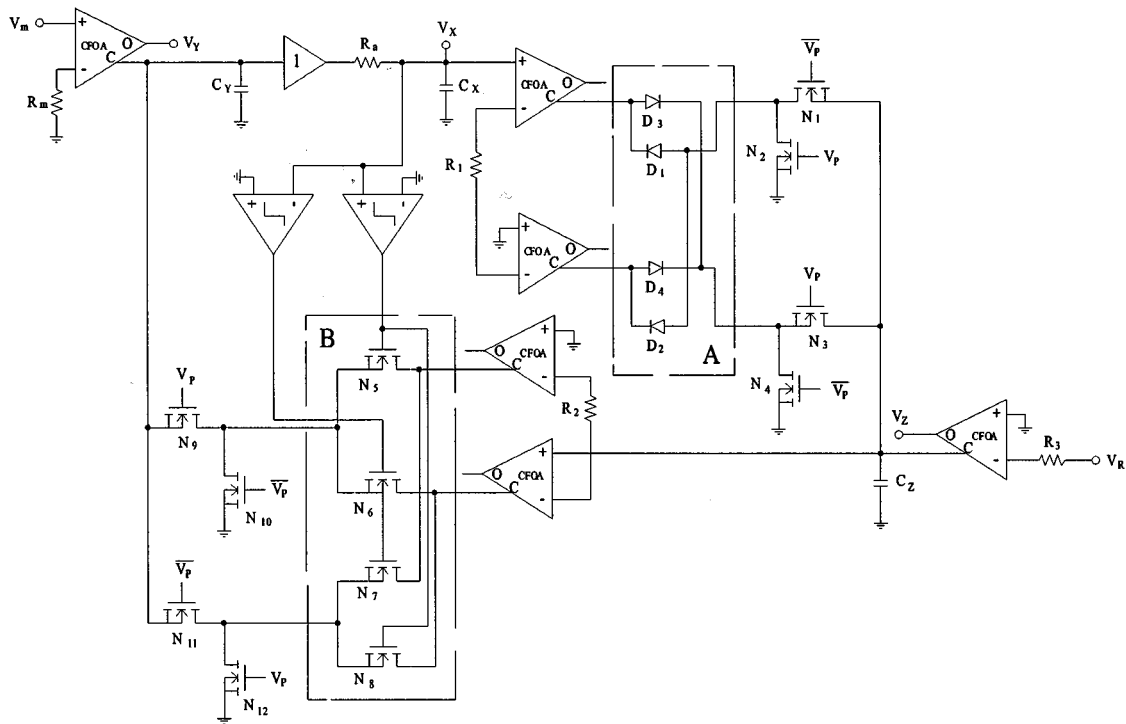

Fig. 4. Experimental realization of the proposed system.

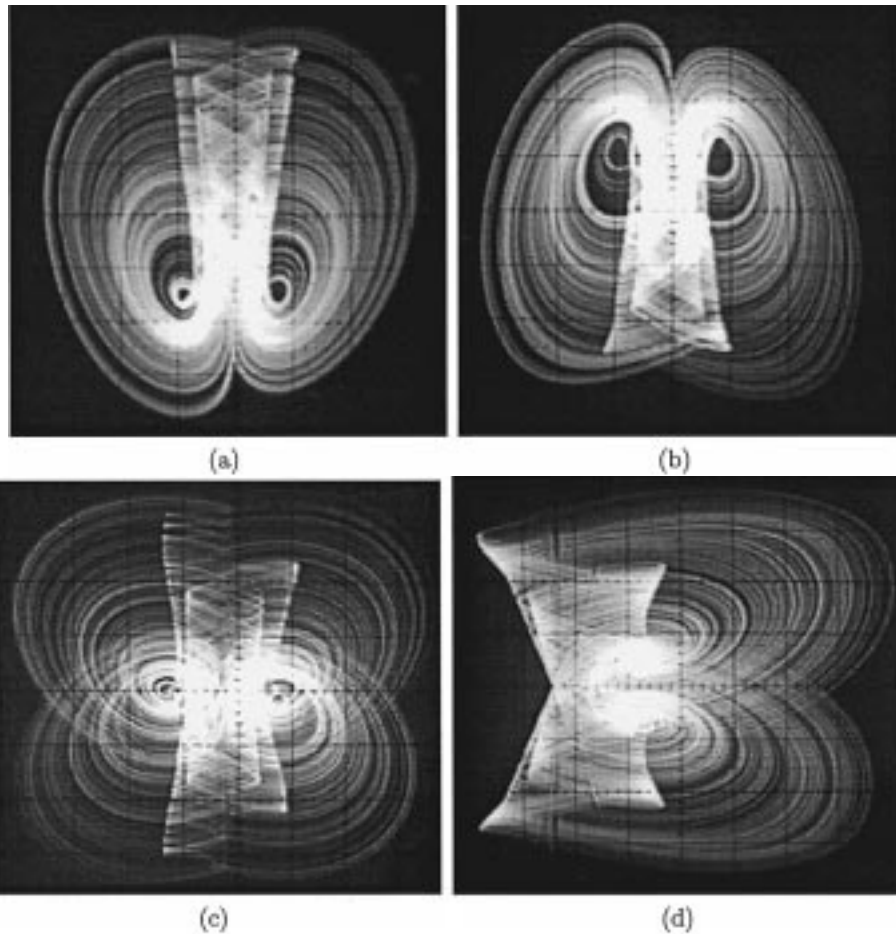

Fig. 5. Experimental observations. (a) Two-wing attractor for the  $S(-, +)$  mode ( $X$  axis: 0.35 V/div,  $Y$  axis: 0.3 V/div). (b) For the  $S(+, -)$  mode ( $X$  axis: 0.35 V/div,  $Y$  axis: 0.3 V/div). (c) Complex (four-wing) butterfly ( $X$  axis: 0.35 V/div,  $Y$  axis: 0.4 V/div). (d)  $Z$ -symmetrical right-half two-wing attractor ( $m = 1$ ) ( $X$  axis: 0.2 V/div,  $Y$  axis: 0.5 V/div).

It is worth noting that the switching constant  $K$  in (2d) can be controlled by the state variable  $Y$  instead of  $X$ . The resulting complex butterfly in this case is shown in Fig. 3(b). It is also worth noting that unlike the Lorenz-type systems of [3], [4] and [8], it is not possible to control the damping along the  $Z$  direction in (2) and hence obtaining smooth wing transitions is not possible.

### III. EXPERIMENTAL VERIFICATION

In this section, we validate our numerical finding by constructing an electronic circuit realizing (2).

Consider the circuit shown in Fig. 4 which involves three capacitors ( $C_X, C_Y, C_Z$ ), the voltages across which correspond to the three states of the system respectively. The bilateral MOS analog switches in the box labeled  $B$  are controlled via the outputs of two comparators which change state following the sign of  $V_X$ . Hence, this part of the circuit realizes  $K$  in (2d). The rest of the MOS switches in the circuit are controlled by an external voltage source  $V_P$ . A reference voltage  $V_R$  (see Fig. 4) is used for the whole circuit.

In the case when  $V_P$  and  $V_R$  are positive valued supplies, the circuit will operate in the  $S(-, +)$  mode. Otherwise, if they are negative valued supplies, the system will operate in the  $S(+, -)$  mode. If a symmetrical square wave signal generator is used to supply both  $V_P$  and  $V_R$ , then the system will alternate equally between the two modes. Note that the nonlinearity  $|X|$  is realized in Fig. 4 by means of a full-wave rectifier circuit [9] composed of the four diodes and the associated op amps. The distortion effect inherent in this circuit is reduced by choosing an appropriate value for  $V_R$ . All op amps in the circuit are current feedback op amps (CFOAS) which facilitate significantly the circuit structure by offering current output signals from their terminals denoted  $C$  [10]. Apart from the op amps involved in the full-wave rectifier part, the rest of the op amps are configured as voltage to current converters.

It can be verified that for the choice of  $C_X = C_Y = C_Z = C, R_1 = R_2 = R_3 = R, R_a = R/a$  and by defining the quantities  $X = V_X/V_R, Y = V_Y/V_R, Z = V_Z/V_R$  and normalizing time with respect to  $RC$ , Fig. 4 realizes equation set (2).

An experimental setup of the circuit was constructed using a CD4016 chip for the MOS analog switches while the comparators are LM311 chips. The CFOAS are AD844 chips and all elements were biased from  $\pm 5$  V supplies.

In Fig. 5(a), the  $V_X - V_Z$  phase projection for the system in the  $S(-, +)$  mode is shown. The corresponding parameters are:  $R = 5.1$  k $\Omega$ ,  $C = 1$  nF,  $R_a = 9.27$  k $\Omega$  and  $V_P = V_R = 0.3$  V. These values correspond to  $a = 0.55$  (recall (2)). By setting  $V_R = -0.3$  V, the system switches to the  $S(+, -)$  mode, as shown in Fig. 5(b). Now, by connecting a square wave generator to both  $V_P$  and  $V_R$ , we observe the complex (four-wing) butterfly shown in Fig. 5(c). Here, the frequency of the source is 150 Hz whereas the center frequency of the circuit ( $\omega_0 = 1/RC$ ) is approximately 31 kHz.

Finally, note that the op amp with the input voltage  $V_m$  can be used to add the constant  $m$  to  $Y$  in order to realize the  $Z$ -symmetrical attractors, as discussed in Section 2. Setting  $V_m = V_R = 0.3$  V ( $m = 1$ ), the right-half two-wing attractor, shown in Fig. 5(d), was observed.

It is worth noting that the box labeled  $A$  (see Fig. 4) which contains the four diodes can be directly replaced with analog switches similar to those in box  $B$  and controlled by the same comparator outputs. This replacement is expected to suite monolithic integration of the circuit;

CFOAS in MOS technology are already available [11]. We have also tested this modified version and obtained similar results.

### IV. CONCLUSION

In this brief, a novel Lorenz-type chaotic system was introduced. The system has two modes of operation; forced switching between which results in the creation of a complex butterfly attractor which is symmetrical with respect to all coordinates. We emphasize the fact that this complex (four-wing) butterfly is a composite attractor formed of two two-wing butterfly attractors. In turn, each two-wing attractor is by itself a composite attractor formed of two one-wing attractors. Consequently, the four-wing attractor is a compound structure; its basic building block is the chaotic attractor corresponding only to one of its wings. This building block attractor has a single equilibrium point and satisfies the conditions proposed in Section IV of [8]. Its dynamics are therefore captured by [8, eq. (18)]. It is possible to confine the trajectories of the complex attractor to any of its separate wings in the electronic circuit of Fig. 4 by using the displacement voltage  $V_m$  and controlling the polarity of the voltage sources  $V_P$  and  $V_R$ .

### REFERENCES

- [1] E. N. Lorenz, "Deterministic nonperiodic flow," *J. Atmos. Sci.*, vol. 20, no. 1, pp. 130–141, 1963.
- [2] C. Sparrow, *The Lorenz Equations: Bifurcations, Chaos, and Strange Attractors*. New York: Springer-Verlag, 1982.
- [3] G. Chen and T. Ueta, "Yet another chaotic attractor," *Int. J. Bifurcation Chaos*, vol. 9, no. 7, pp. 1465–1466, 1999.
- [4] T. Ueta and G. Chen, "Bifurcation analysis of Chen's attractor," *Int. J. Bifurcation Chaos*, vol. 10, no. 8, pp. 1917–1931, 2000.
- [5] K. M. Cuomo, A. V. Oppenheim, and S. H. Stogatz, "Synchronization of Lorenz based chaotic circuits with applications to communications," *IEEE Trans. Circuits Syst. II*, vol. 40, pp. 626–633, Oct. 1993.
- [6] O. A. Gonzales, G. Han, J. P. de Gyvez, and E. Sanchez-Sinencio, "Lorenz-based chaotic cryptosystem: A monolithic implementation," *IEEE Trans. Circuits Syst. I*, vol. 47, pp. 1243–1247, Aug. 2000.
- [7] E. H. Baghious and P. Jarry, "Lorenz attractor from differential equations with piecewise-linear terms," *Int. J. Bifurcation Chaos*, vol. 3, no. 1, pp. 201–210, 1993.
- [8] A. S. Elwakil and M. P. Kennedy, "Construction of classes of circuit-independent chaotic oscillators using passive-only nonlinear devices," *IEEE Trans. Circuits Syst. I*, vol. 48, pp. 289–307, Mar. 2001.
- [9] C. Toumazou, F. J. Lidgley, and S. Chattong, "High-frequency current conveyor precision full-wave rectifier," *Electron. Lett.*, vol. 30, pp. 745–746, 1994.
- [10] A. M. Soliman, "Applications of the current feedback operational amplifiers," *Analog Integr. Circuits Signal Proc.*, vol. 11, no. 11, pp. 265–302, 1996.
- [11] S. A. Mahmoud and A. M. Soliman, "Novel MOS-C balanced-input balanced-output filter using the current feedback operational amplifier," *Int. J. Electron.*, vol. 84, no. 5, pp. 497–485, 1998.