

Title	Design of miniaturized wireless sensor mote and actuator for building monitoring and control
Authors	Jafer, Essa;O'Flynn, Brendan;Ó Mathúna, S. Cian;Wang, Wensi S.
Publication date	2010
Original Citation	Jafer, E.; O'Flynn, B.; O'Mathuna, C.; Wensi Wang; , "Design of miniaturized wireless sensor mote and actuator for building monitoring and control," Telecommunications (ICT), 2010 IEEE 17th International Conference on , vol., no., pp.887-892, 4-7 April 2010 doi: 10.1109/ICTEL.2010.5478832 URL: <a href="http://ieeexplore.ieee.org/stamp/stamp.jsp?tp=&amp;arnumber=5478832&amp;isnumber=5478598">http://ieeexplore.ieee.org/stamp/stamp.jsp?tp=&amp;arnumber=5478832&amp;isnumber=5478598</a>
Type of publication	Conference item
Link to publisher's version	<a href="http://ieeexplore.ieee.org/stamp/stamp.jsp?tp=&amp;arnumber=5478832&amp;isnumber=5478598">http://ieeexplore.ieee.org/stamp/stamp.jsp?tp=&amp;arnumber=5478832&amp;isnumber=5478598</a> - 10.1109/ICTEL.2010.5478832
Rights	©2010 IEEE. Personal use of this material is permitted. However, permission to reprint/republish this material for advertising or promotional purposes or for creating new collective works for resale or redistribution to servers or lists, or to reuse any copyrighted component of this work in other works must be obtained from the IEEE.
Download date	2024-12-07 09:02:04
Item downloaded from	<a href="https://hdl.handle.net/10468/181">https://hdl.handle.net/10468/181</a>



# UCC

**University College Cork, Ireland**  
Coláiste na hOllscoile Corcaigh

# Design of Miniaturized Wireless Sensor Mote and Actuator for Building Monitoring and Control

Essa Jafer<sup>1</sup>, Brendan O'Flynn<sup>1</sup>, Cian O'Mathuna<sup>1</sup>, and Wensi Wang<sup>1</sup>  
<sup>1</sup>Tyndall National Institute, University College cork, Cork/Ireland  
Essa.jafer@tyndall.ie

## Abstract

In this paper, a wireless sensor network mote hardware design and implementation are introduced for building deployment application. The core of the mote design is based on the 8 bit AVR microcontroller, Atmega1281 and 2.4 GHz wireless communication chip, CC2420. The module PCB fabrication is using the stackable technology providing powerful configuration capability. Three main layers of size 25 mm<sup>2</sup> are structured to form the mote; these are RF, sensor and power layers.

The sensors were selected carefully to meet both the building monitoring and design requirements. Beside the sensing capability, actuation and interfacing to external meters/sensors are provided to perform different management control and data recording tasks.

Experiments show that the developed mote works effectively in giving stable data acquisition and owns good communication and power performance.

*Keywords Building Performance, RF Characteristics, Wireless Sensor Network, Motes deployment and Sensors interfacing.*

## 1. Introduction

Traditionally building automation systems are realized through wired communications. However, the wired automation systems require expensive communication cables to be installed and regularly maintained and thus they are not widely implemented in industrial plants because of their high cost [1, 2]. Therefore there is an urgent need for cost-effective wireless systems that enables significant cost savings which comes in the form of cabling, labor, materials, testing, and verification [3]. For example, the installation cost of a light switch in a building facility can be as high as 10–30 times the cost of the switch; this estimate does not include the possibility of additional work such as conduit installation and infrastructure work. Furthermore, the installation cost of a large number of existing building facilities can be prohibited high due to the existence of pollution agents such as asbestos; in this case, wireless sensor networks and power line carrier are the only solution viable for retrofitting buildings with business automation machinery. Low cost power line carrier still shows serious reliability issues that limit the use of the technology [4]. Advancements in the sensor and wireless industries provide a significant opportunity for building owners, operators, and energy service companies to consider controls upgrades to improve the overall energy efficiency, become more demand responsive, and to improve the indoor environmental conditions.

Nowadays, Wireless Sensors network (WSN) merges a wide range of information technology that spans hardware, systems software, networking, and programming methodology [5]. A network of wireless sensors consists of a large number of energy-autonomous sensors distributed in an area of interest. Each node monitors its local environment, locally processes and stores the collected data so it can be used by other nodes. It shares this information with the other neighboring nodes by using a wireless link. Since the nodes are many and since they might be deployed in regions difficult to access, they should not require any maintenance. Three main factors should be considered for WSN mote design including hardware platform, operating system and the communication protocol. The development aspects of the wireless sensor node are the main focus of this paper taking into consideration the expected technical challenges and the introduced design principles.

In this paper, first an overview of the mote top level system will be described giving the different offered functionalities of the main unit. Section 2 will review design details and selected hardware of the mote including the sensors and interface circuitries. The system actuation implemented by the wireless module will be introduced in Section 3. Section 4 will be dealing with the power consumption issues of the motes and the different techniques used to reduce the current consumption of the node system and accordingly increase the battery life time. Finally this paper is concluded in Section 5.

## 2. WSN node design

### A. System Architecture

The mote is designed in modular mode. As Figure 1 shows, the system contains four main units, these are data processing unit, RF communication unit, sensors/meters and actuation unit and power supply management unit. The data processing unit can make valid control for other units.

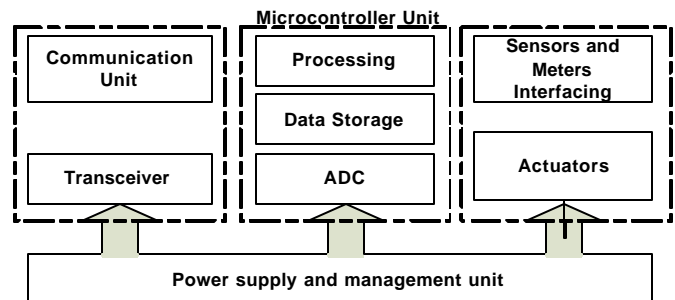
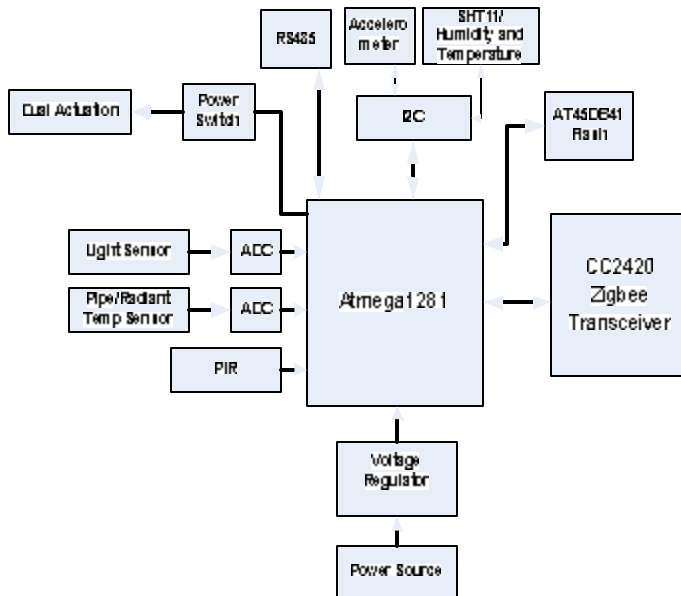

Figure 1: Top level system block diagram of the WSN mote

## B. System Functional Units

To have deeper look into the developed system, the block diagram of the mote functional units is shown in Figure 2. The multi-sensor layer was designed to interface with number of selected sensors as well as incorporating additional capability for use within the Building environment. This includes dual actuation capabilities for any AC/DC system using an external high power relay based system for devices which consume up to 280 V and 25 A (to turn on and off appliances) as well as an onboard low power switch to enable the actuation facility. The type of on-board sensor is either digital communicating with the microcontroller through serial bus interface like I2C or analogue connected with any of the ADC channels. The two external sensors/meters interfaces are dedicated to any meter using MODBUS protocol [6] and variable resistance temperature sensors. The MODBUS meter is exchanging data/commands through RS485 serial communications. .

This interface layer was also designed to incorporate external flash memory (Atmel AT45DB041). The layer features a 4-Mbit serial flash for storing data, measurements, and other user-defined information. It is connected to one of the USART on the ATmega1281. This chip is supported by TinyOS and embedded C which uses this chip as micro file system. This device consumes 15 mA of current when writing data.



**Figure 2:** block diagram of the mote functional units

ATmega1281 is a high performance, low power AVR 8-bit microcontroller with advanced RISC architecture and owns rich hardware resources. The CC2420 was used because of its excellent RF performance and low power consumption. The photos of both the RF and sensor layers are shown in Figure 3. The complete 3 layers stackable 25mm mote is shown as well.

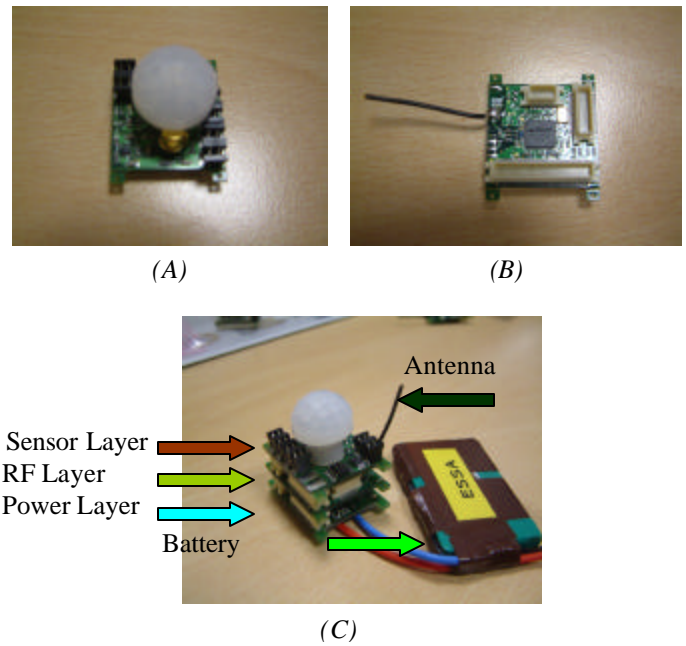

**Figure 3:** Photos of the (a) Developed sensor layer, (b) Zigbee and processor layer, and (c) The complete 25mm stackable mote

## C. Sensors Selection

Sensors are hardware devices that produce measurable response to change in physical condition. In this section, the different types of sensors and interfaces designs selected for the building monitoring application are illustrated. The main objective of these sensors besides recording the building data is to make the mote reliable for large scale deployment with low cost and low power consumption.

### 1) Occupation Sensor (Passive infrared PIR)

All objects constantly exchange thermal energy in the form of electromagnetic radiations with their surrounding. Radiation from the human body is considered to lie in the range of 8-14  $\mu\text{m}$ , hence infrared sensors that are sensitive in this range would be able to detect humans within their detection area.

The passive infrared sensor works on the principle of pyroelectricity. The principle is based on the fact that certain crystals become electrically charged when their temperature changes. They are essentially capacitors whose dielectric is made from a crystal that has been spontaneously polarized. When the dielectric absorbs infrared radiations, increase in temperature reduces the polarization and the voltage across the sensor changes.

Detecting the occupancy of the rooms inside the building was one of the essential requirements to be monitored, there was need to find suitable PIR sensor module. The Panasonic AMN44122 [7] was selected for this purpose since it provides the required functionality in a module that is smaller, more convenient and of lower energy consumption than the custom circuitry used in the prototype. Furthermore, the module provides a digital detection output that is used to trigger an interrupt on the processor when activity registers on the

sensor. Analog sampling of the PIR signal and software detection processing is no longer required as the interrupt signal is a digital one. A simple lab test has been performed to identify actual performance of the PIR sensor and obtained similar results to those in the datasheet. However, it was found that the actual detection region with high reliability is a little smaller than the detection region specified in the datasheet. Table 1 shows the comparison between the performance of PIR sensor provided in the datasheet and the real performance obtained by our lab test.

**Table 1:** AMN44122 PIR sensor detection range values

Items		Datasheet	Lab Test
Detection Distance		10m (32.808ft)	9m (29.528ft)
Detection Range	Horizontal	110°	90°
	Vertical	93°	90°

2) Humidity/Temperature Sensor

Relative humidity (RH) is an important indicator of air quality in buildings. Extremely low or high humidity levels (the comfort range is 30 - 70% RH) can cause discomfort to workers and can reduce building longevity. Humidity control also dictates building energy consumption during heating seasons.

Conventional sensors determine relative air humidity using capacitive measurement technology. For this principle, the sensor element is built out of a film capacitor on different substrates (glass, ceramic, etc).The dielectric is a polymer which absorbs or releases water proportional to the relative environmental humidity, and thus changes the capacitance of the capacitor, which is measured by an onboard electronic circuit.

The Temperature and Humidity sensor SHT11 [8] shown Figure 4 was used on the sensor board which integrates signal processing, tiny foot print and provide a fully calibrated digital output. It uses I2C serial interface to communicate with the microcontroller and provide either the humidity or temperature data based on the received commands.

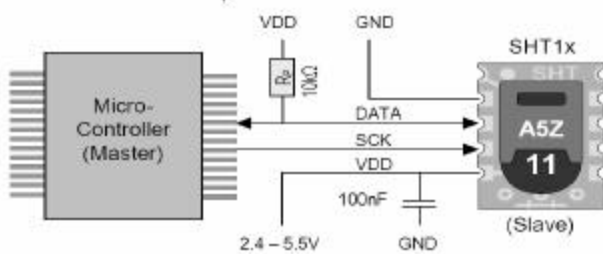

**Figure 4:** Typical application circuit of the SHT11

3) Acceleration and Motion Sensors

The detection of the windows/doors status was one of the building parameters required to be monitored by the WSN node. 3-axis accelerometer was selected for this application since it can provide useful angle information which helps to know how wide door/window is opened or closed. The LIS302DL is an ultra compact low-power three axes linear accelerometer was integrated in the node design [9]. The device can be interfaced through either I<sup>2</sup>C or SPI serial protocol. The mote orientation can be easily calculated using the accelerometer data providing additional feature for future applications. In order to test and calibrate the sensor, special Labview GUI was developed to display the sensor measurements and control all device units through writing into the specified registers as shown in Figure 5.

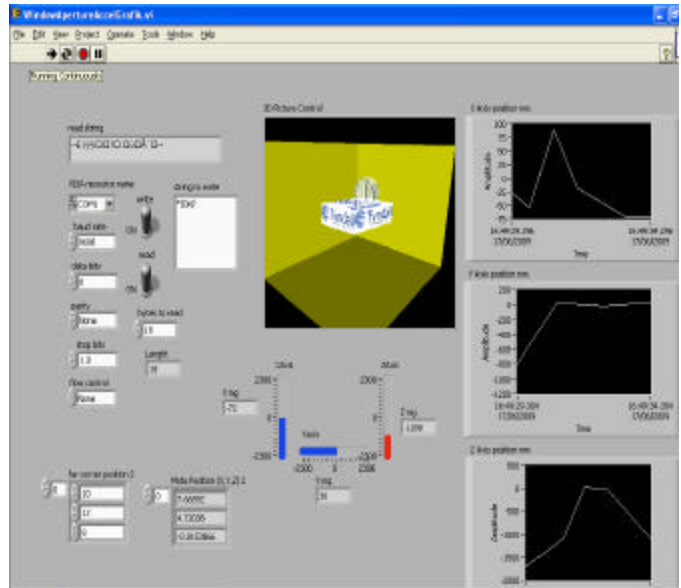

**Figure 5:** 3-Axis accelerometer LABVIEW GUI

The main design challenge with using the accelerometer is that the microcontroller has to be continuously active to record sensor data which means high current consumption and short batter life time. In order to overcome this problem, a mechanical vibration sensor with very small package was used in this design to provide an external interrupt to the Atmel microcontroller when there is any kind of motion at any direction as presented by Figure 6.

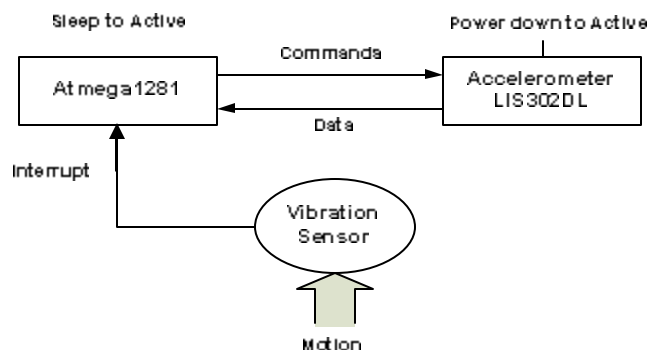

**Figure 6:** Functional block diagram of e motion sensor design

From the previous figure, it can be seen that using the motion sensor can help to put both microcontroller and accelerometer in power down modes when there is no activity. The vibration switch is consuming negligible current and using simple analog circuitry to generate the interrupt pulse.

#### 4) RS485 for Water Flow Meter Interfacing

It is required to get the flow rate measurements from different locations inside the building where pipes made from different materials and have wide scale diameter size. The ultrasonic non-intrusive was found to be the optimal solution for measuring the water flow rate of the water on building pipes since it is not disturbing the existing pipes installation and gives flexible testing option. One of the four miniaturized on-board connectors was dedicated to the water flow meter interfacing. Half duplex RS485/RS232 IC was used to interface the water flow meter with the Universal Asynchronous Receiver Transmitter (UART) of microcontroller using the standard industrial MODBUS protocol.

The STUF-300EB from Shenitech [10] was used for this application. It provides excellent capabilities for accurate liquid flow measurement from outside of a pipe. The proprietary signal quality tracking and self-adaptation technologies allow the system to optimally adapt to different pipe materials and liquid property changes automatically. The STUF-300EB has a surge-protected, isolated RS485 interface with MODBUS support makes it suitable for reliable flowmeter networking.

The Modbus can be implemented in two different modes: RTU (Remote Terminal Unit) and ASCII. The water flow meter uses the ASCII mode with the frame format given below:

**Table 2:** Modbus ASCII Message Frame

Start	Address	Address	Data	LRC	End
1 char	2 chars	2 chars	0 up to 2×252 char(s)	2 char	2 char CR, LF

A Modbus message is placed by the transmitting device into a frame with start and end headers. The receiver will use identify the beginning and end of the message using the two headers and apply error checking using the Longitudinal Redundancy Checking (LRC) algorithm.

To verify the performance of the meter interfacing, first the ultrasonic device was deployed in a chosen site inside the building. Initially three parameters are provided by the meter can be used to know whether the installation is good or needs more adjusting Figure 7 shows the water flow readings obtained from running the meter for almost 4 days. The start and end time of each flow activity is marked. In general the readings fall in the range of 0 – 2.5 m<sup>3</sup>/h.

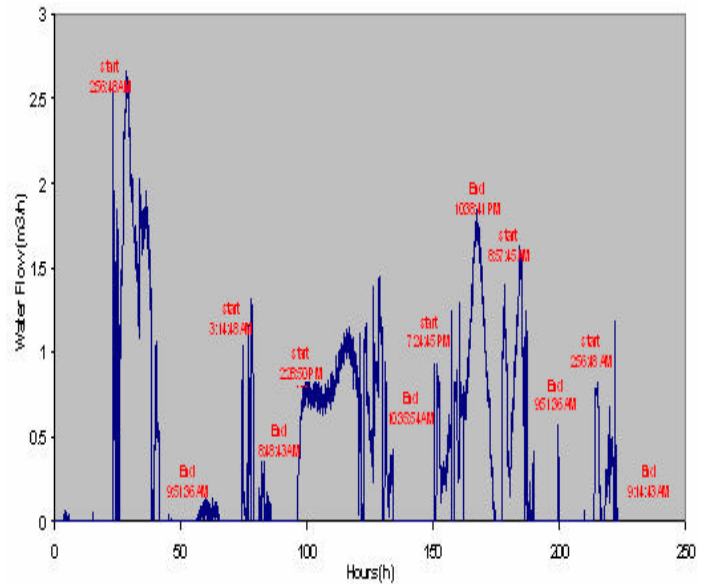
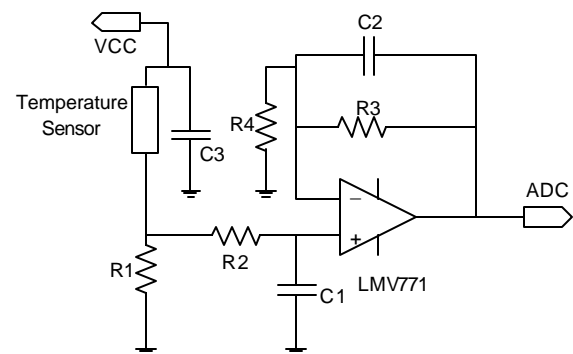

**Figure 7:** Water flow rate measurements

#### 5) Water Pipe temperature Sensor Interfacing

The monitoring of the water temperature that is passing in the building pipes was needed as part of the wireless sensor system. Surface Mount Temperature Sensor from SIEMENS [11] was selected for this application as non-intrusive units and can be mounted directly on a pipe inlet to sense the temperature of water passing through.

The temperature sensor here acts as a resistor whose resistances varies with the temperature. Voltage divider based circuit was designed to interface the node with the sensor through one of the on-board connectors. A low noise amplifier with a certain gain factor is used in the circuit to adapt the range of the output signal to be suitable for the ADC channel as shown in Figure 8.



**Figure 8:** Schematic of the water pipe temperature sensor interface circuitry

The sensor performance was compared with the existing wired sensors read by the Building Management System (BMS) as shown in Table 3. It is very clear that the wireless sensor displays a comparative performance to the wired one and can provide useful data from number of pipe sites inside the building. It has to be mentioned that the temperature of the pipe surface is always higher than the water by a few degrees. This



will be taken into account in the calibration process by the mote to get accurate readings.

**Table 3:** Verifying the readings of the wireless pipe temperature sensor with the existence BMS wired sensor

Temp °C (BMS)	Temp °C (Sensor)	Temp °C (Calibrated Sensor)
20.25	19.01	20.01
23.12	21.03	22.03
30.45	29.5	30.5
45.21	43.2	44.2
48.87	47.62	48.62

### 3. Actuation Capability

The wireless control of switching on/off different types of AC loads in the building is meant to be the second application for the node beside the data monitoring. The base station will be responsible of collecting and processing the different types of sensors data and send the commands to some of designated nodes to perform actuation like switching on/off light, heat pumps, water valves or radiators.

To achieve this goal on a miniaturized node, number of design options was considered taken into consideration many aspects like the effect of AC high voltage on the low power circuitry of the node and also the possible ways to interconnect with different types of single/three phases loads. The current design provides two options, first controlling small current, up to 2 Amps, ac loads like PCs using on-board PHOTOMOS relay which is optoelectronic device drives a power MOSFET [12]. Second option is providing the ability to connect an external relay that derives higher current loads through one of the on-board connectors.

To examine the actuation capability of the node, a small demonstration was setup inside one of the building rooms to control the operation of heat radiators as shown in Figure 9. Another node was deployed in the same room to monitor the room temperature/humidity and send the readings to the base station which will take an action and send the appropriate command to the actuator to either switch off or on the radiator.



**Figure 9:** Wireless actuation for heat radiators

### 4. Node Power Consumption

The power consumption of the node was critical issue for the design to make it reliable for long term deployment. Primarily the mote will be powered from a rechargeable battery with limited current capacity. In order to increase the operation life time of the mote, a number of SW/HW techniques were employed. At the HW level, the sensor layer has the ability to shut down the power from the unused sensors. Low current voltage regulator was integrated in the RF layer to provide stable voltage level. Also we focused on how to employ efficiently the different power saving modes of both the microcontroller and transceiver units that are measured and presented by Figure 10.

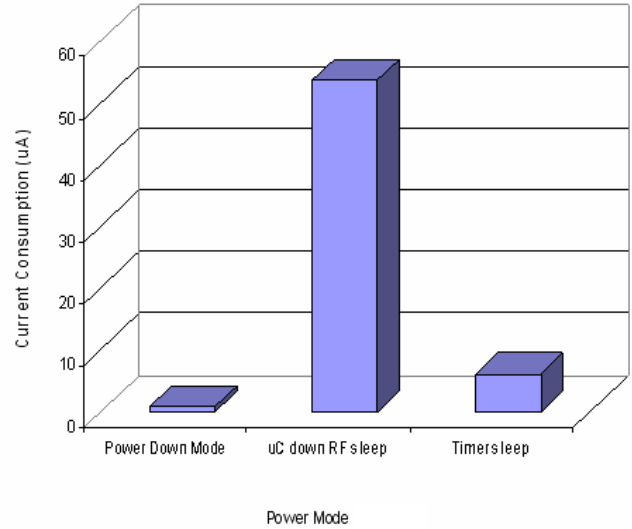

(a)

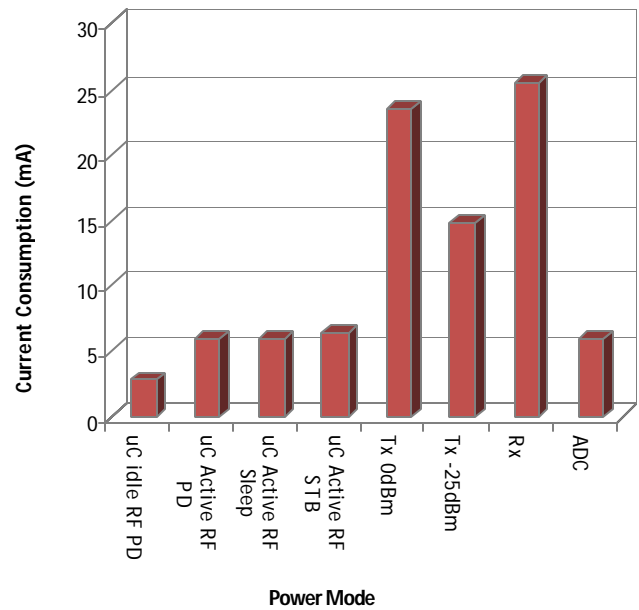

(b)

**Figure 10:** Current consumption at different power modes of both the microcontroller (uC) and transceiver (RF) units. PD and STB refer to Power Down and Standby modes

From the previous figure number of power down options are available to reduce the overall node current consumption. The best scenario is to put both the microcontroller and transceiver in deep power down mode when there is no data transmission which brings down the total current to nearly 6  $\mu$ A. Here the duty cycle of the has to be carefully considered for all the sensors to provide frequent useful data and at the same time guarantee low power operation when there is no activity. In order to demonstrate such behavior, the node has been programmed to send the sensors data every 15 seconds and go to power down after. The obtained current consumption measurements are given in Figure 11.

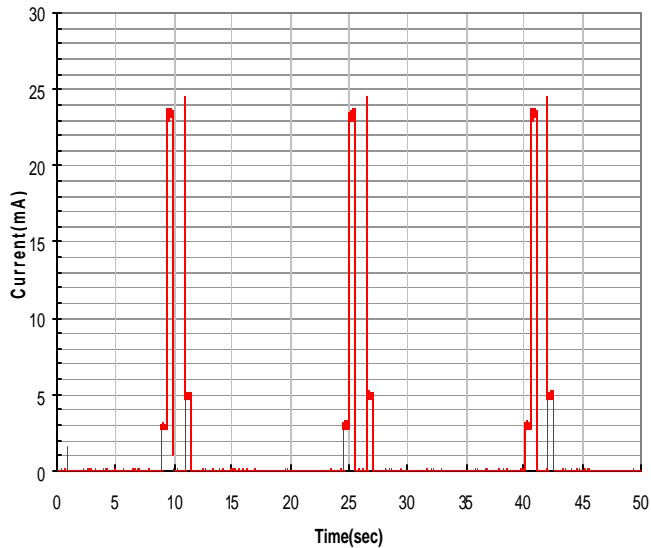

**Figure 11:** Node current consumption behavior at fixed duty cycle

## 5. Conclusions

This paper presents the design and development of a miniaturized WSN mote based on Zigbee technology for building monitoring, exploring its system control management and technology characters. The stackable technique was adopted in this work to manufacture efficiently the mote layers within small cubic size.

The node can implement wide scale of stable sensors/meters data acquisition to provide the needed functions. In addition to the building monitoring, it has the capability to act as an actuator using either on-board relay for low current loads or can be connected easily to an external relay to control high current loads.

The power consumption of the node was studied carefully to make it reliable for long term deployment. Number of power management were implemented in the node design to reduce overall current consumption. It is well clear that powering down non active units and using low duty cycle have the greatest impact of the node power consumption. These two factor need to be compromised with the requirements of the sensors functionalities to reach optimal performance.

## Acknowledgments

The authors would like to acknowledge the support of Science Foundation Ireland (SFI) and the funding provided to the National Access Program (NAP) at the Tyndall National Institute, and Enterprise Ireland all of which have contributed to this work. Tyndall are part of the SFI funded CLARITY Centre for Sensor Web Technologies

## 6. References

- [1] J.A. Gutierrez, "On the use of IEEE Std. 802.15.4 to enable wireless sensor networks in building automation. *International Journal of Wireless Information Networks*", 14(4), pp. 295-301, (2007).
- [2] F. Osterlind, E. Pramsten, D. Roberthson, J. Eriksson, N. Finne, T. Voigt, "Integrating building automation systems and wireless sensor networks", *IEEE Symposium on Emerging Technologies and Factory Automation*, pp. 1376-1379, (2007).
- [3] N. Kurata, Jr. Spencer, M. Ruiz-Sandoval, "Risk monitoring of buildings with wireless sensor networks. *Structural Control and Health Monitoring*", 12 (3-4), pp. 315-327, (2005).
- [4] M. Kintner-Meyer, "Opportunities of wireless sensors and controls for building operation", *Energy Engineering: Journal of the Association of Energy Engineering*, 102 (5), pp. 27-48, 2005.
- [5] J. Xu, B. You, J. Cui, J. Ma, X. Li, "Design of nodes for embedded and ultra low-power wireless sensor networks" *Proceedings of SPIE – 5<sup>th</sup> International Symposium on Instrumentation Science and Technology*, Vol 7133, 2009.
- [6] MODBUS Industrial Protocol, [www.modbus.org](http://www.modbus.org)
- [7] AMN44122 Passive Infrared (PIR) Motion Sensor, Passive, <http://pewa.panasonic.com/>.
- [8] SHT11 Digital humidity and temperature sensor, <http://www.sensirion.com>
- [9] LIS302DL, 3-axis smart digital output accelerometer, <http://www.st.com>
- [10] STUF-300EB Ultrasonic Water Flowmeter, from Shenitech, <http://www.shenitech.com>
- [11] Surface mount pipes temperature sensor, <http://www.buildingtechnologies.siemens.com>
- [12] Panasonic PHOTOMOS optically isolated relays, <http://pewa.panasonic.com>