

Title	Reliability analysis of bridges retrofitted with tuned mass dampers
Authors	Pakrashi, Vikram;O'Connor, Alan J.;Basu, Biswajit
Publication date	2004
Original Citation	Pakrashi V., O'Connor A.J., Basu, B., 2004. Reliability analysis of bridges retrofitted with tuned mass dampers. In: Bridge Engineering Research in Ireland (BEI) Second Symposium on Bridge Engineering in Ireland. Belfast, Ireland 4 – 5 Nov 2004
Type of publication	Conference item
Rights	© 2004, Vkiram Pakrashi, Alan J. O'Connor, Biswajit Basu. - http://creativecommons.org/licenses/by-nc-sa/3.0/
Download date	2024-12-03 21:31:34
Item downloaded from	https://hdl.handle.net/10468/257



UCC

University College Cork, Ireland
 Coláiste na hOllscoile Corcaigh



Pakrashi V., O'Connor A.J., Basu, B., 2004. Reliability analysis of bridges retrofitted with tuned mass dampers. In: Bridge Engineering Research in Ireland (BEI) *Second Symposium on Bridge Engineering in Ireland*. Belfast, Ireland 4 - 5 Nov 2004

CORA Cork Open Research Archive <http://cora.ucc.ie>

Reliability of Flexible Guideways with TMDs

Vikram Pakrashi¹, Alan John O' Connor² and Biswajit Basu³

Department of Civil, Structural and Environmental Engineering, Trinity College Dublin

Abstract

This paper investigates the enhancement in the performance of bridges resulting from the use of tuned mass dampers (TMD) to reduce vibration induced by bridge-vehicle interaction. The enhancement in performance is demonstrated through the relative improvement of the reliability index of the structure once TMDs are retrofitted. In computing the reliability index the paper considers statistical variability in both the vehicle loading and the bridge resistance. Improvements in the bridge response due to installation of TMD are evident from improvement in the reliability index computed using the first order second moment (FOSM) method. The vehicle is modelled as a standard quarter car while the bridge is modelled as an Euler Bernoulli beam element. Performance of bridge often deteriorates with time due to several factors. The efficiency of TMDs in improving the reliability of the bridge response with respect to degradation of the bridge condition with time is also shown.

1.Introduction

The interaction of bridges and the vehicles that traverse them gives rise to dynamic magnification of static effects. The displacement due to vibration results in the generation of magnified stresses due to dynamic effects, which increases the probability of failure and decreases the reliability index of the bridge with respect to its maximum response. However, with a proper vibration control mechanism like a TMD installed, dynamic stresses can be lowered and as a direct consequence, the reliability of the structure can be relatively improved. Bridge-vehicle interaction also increases the vertical acceleration of the vehicle itself. And becomes a source of discomfort for the passengers. By controlling vibration, problems related to excess stress on vehicle and passenger discomfort are solved to a great extent.

Behaviour of a bridge under the action of moving load has been discussed in details by Fryba [1]. Hayashikawa and Watanabe [2], Cai et al [3], Kłasztorny and Langer [4], Genin et al [5] have discussed the problem of a quarter car model of a vehicle moving over a flexible guideway modelled as an Euler Bernoulli beam element. To mitigate vibration effects in bridges due to vehicular loading, several control mechanisms have been employed. In this paper, a passive TMD has been chosen as a vibration control mechanism. The frequency and damping ratio of the TMD is adjusted or tuned with that of bridge in such a way, that the TMD absorbs the major part of excitation and mitigates the vibration of bridge. Den Hartog [6] showed the efficiency of a TMD to suppress vibrations of a SDOF system under harmonic loading. With damping included, the tuning frequency and damping basically become outputs

of an optimisation problem. The TMDs perform satisfactorily when the exciting frequency has a narrow window (Inman [7]).

For bridge vibration problems, tuning proposed by Den Hartog has not always been very efficient. Igusa and Xu [8] have examined both single and multiple TMDs with the natural frequency distributed over a range and have found multiple TMDs to be more effective and robust than the single one. Park and Reed [9] have found uniformly distributed TMDs to perform better than linearly distributed ones. Abe' and Fujino [10], Kareem and Kline [11], Yamaguchi and Harnpornchai [12] and Wang et al [13] have discussed the advantages of multiple TMDs over single TMD. Kwon et al [14] and Jo et al [15] have considered interaction of high-speed vehicles with three span steel box girder bridges and have advocated the use of critical damping value in TMD suggested by Tsai [16] to avoid the beating phenomenon due to inadequate damper tuning. Warburton and Ayorinde [17] however, have previously showed that for a TMD with small mass ratio with respect to the bridge, exact tuning may turn out to be rewarding.

All the above-mentioned formulations of the problem consider both resistance and loading to be deterministic. In reality there are considerable variability in both load and resistance. To account for this variability, one can opt for a probabilistic formulation of the variables. For such a formulation, the idea of safety of a structure will be related to its reliability index computed for different failure modes -as found from the maximum response of the structure. The reliability index can be computed using the basics of first order second moment (FOSM) theory. This paper considers the variability in loading and resistance of a bridge and discusses the improvement of bridge response using TMD from a reliability perspective.

2. Solution of the Bridge-Vehicle interaction Problem

2.1 Description of the problem

The bridge is modelled as a homogeneous Euler Bernoulli beam with equivalent stiffness. The mass per unit length of the beam is m . Mass of the vehicle wheel is m_w and that of the body is m_b . The subscripts w and b represent the wheel and the body of the vehicle respectively. The vehicle is taken as a quarter car model moving with a constant velocity (v) and possessing two degrees of freedom representing the vertical motions of wheel and body. An assembly consisting of two sets of springs (k_b, k_w) and dampers (c_b, c_w) represents the suspension system of vehicle. The yield stress (f_y) of the material, the self-weight of the beam (ml) and the total mass of the vehicle (m_w+m_b) are taken as random variables. Angular movements of the vehicle are neglected. Tuned mass dampers are modelled to be connected to the beam with a parallel spring and damper system. For the case of multiple tuned mass dampers, the i^{th} TMD with mass m_{zi} at a distance x_i from the left support has a spring stiffness k_{zi} and a damping value c_{zi} . The vehicle is assumed to move on smooth surface, never losing contact with it. Bouncing and impact effects are not considered. The beam is modelled as simply supported. The length, moment of inertia, section modulus and modulus of elasticity of the material of the beam are given by l, I, z_x and E respectively. Figure1 shows the model of bridge vehicle interaction with TMD installed as described in this section.

$(n^2\pi^2/l^2)(EI/m)^{1/2}$. The damping in the beam is considered to be small. Using the orthogonality property of the assumed eigenmodes $\Phi_n(x)$, we have

$$\int_0^l \Phi_n^2(x)dx = l/2 \quad (5)$$

Following standard technique of separating variables, i.e. multiplying the right hand side of equation (4) by eigenmodes and integrating over length l , gives the following relation

$$\ddot{q}_n(t) + 2\xi_n\omega_n\dot{q}_n(t) + \omega_n^2q_n(t) = \frac{2}{l} \int_0^l \frac{F(x,t)}{m} \Phi_n(x)dx = R(t) \quad (6)$$

where $n=1,2,\dots$ and $q_n(t)$ represents the response of beam with respect to time as per equation (6) for n^{th} mode of vibration.

Integrating the right hand side of equation (6) and incorporating the sampling property of Dirac Delta function, the right hand side of equation (6) is determined to be

$$R(t) = \frac{2}{ml} \{ (m_w\ddot{y}_w + m_b\ddot{y}_b + (m_w + m_b)g) \text{Sin}(n\pi vt/l)\Delta + \sum_{i=1}^{m'} (m_{zi}g - m_{zi}\ddot{z}_i) \text{Sin}(n\pi x_i/l) \} \quad (7)$$

The displacement of the beam at distance x from left and at an instant of time t after the vibration starts is given by

$$y(x,t) = \sum_{j=1}^n q_j(t)\Phi_j(x) \quad (8)$$

2.4. Transformation to non-dimensional coordinates

Cai et al [3] had suggested finding maximum static deflection at the centre point with respect to the first assumed mode as:

$$y_m = q_1\Phi_1(l/2) = 2(m_b+m_w)g/(ml\omega_1^2) \quad (9)$$

Here ω_n is denoted as the n^{th} natural frequency of the beam. The transformed non-dimensional variables used in the equation are $\omega_b, \zeta_b, \omega_w, \zeta_w, \varepsilon, \varepsilon_w, \varepsilon_b, \gamma_m, \Omega, \gamma_f, \xi_v$ and ξ , each being equal to $(k_b/m_b)^{1/2}, c_b/(2m_b\omega_b), (k_w/(m_w+m_b))^{1/2}, c_w/2(m_w+m_b)\omega_w, (m_w+m_b)/ml, m_w/ml, m_b/ml, m_w/m_b, \omega_1/\omega_w, \omega_b/\omega_w, vt/l$ and x/l respectively.

The variable in time, t is transformed to non dimensional τ , where $\tau=\omega_1t$. Equations 1, 2,3 and 6 are transformed to non-dimensional equations 10,11,12 and 13 respectively.

$$\Omega^2\ddot{Y}_b + 2\zeta_b\Omega\gamma_f(\dot{Y}_b - \dot{Y}_w) + \gamma_f^2(Y_b - Y_w) = 0 \quad (10)$$

$$\Omega^2\ddot{Y}_w + \left(\frac{\varepsilon b}{\varepsilon_w}\right)\Omega^2\ddot{Y}_b + 2\zeta_w\left(\frac{\varepsilon}{\varepsilon_w}\right)\Omega(\dot{Y}_w + \dot{Y}) + \left(\frac{\varepsilon}{\varepsilon_w}\right)(Y_w + Y) = 0 \quad (11)$$

$$\Omega^2\ddot{Z}_i + 2\zeta_z\Omega\gamma_z(\dot{Z}_i - \dot{Y}) + \gamma_z^2(Z_i - Y) = 0 \quad (12)$$

$$\ddot{u}_n + 2\zeta_n\frac{\omega_n}{\omega_1}\dot{u}_n + \frac{\omega_n^2}{\omega_1^2}u_n = \frac{2}{ml} \left\{ \left(\frac{1}{2} + \varepsilon_w\ddot{Y}_w + \varepsilon_b\ddot{Y}_b\right) \text{Sin}(n\pi\tau/2)\Delta + \sum_{i=1}^{m'} \left(\frac{1}{2} \cdot \frac{\varepsilon_{zi}}{\varepsilon} - \varepsilon_{zi}\ddot{z}_i\right) \text{Sin}(n\pi x_i/l) \right\} \quad (13)$$

The non-dimensional uppercase symbols are obtained by dividing corresponding lowercase symbols by y_m . Similarly, u_n is transformed from q_n through division by y_m .

The parameter Δ is introduced because of the sampling property of Dirac Delta function. The value of Δ is 1 when the vehicle is on the bridge and 0 immediately after the vehicle leaves the bridge.

2.5. Generation of matrices

It is possible to work with the current formulation accounting for any number of beam modes with any number of TMD positioned arbitrarily. The damping ratio for the bridge is very small and hence the transient response should be taken into account. In the present problem exact tuning has been selected. For multiple tuned mass dampers, the TMDs are uniformly distributed. In what follows $\Phi_n(\xi_v)$ will stand for $\text{Sin}(n\pi x/l)$ and $\Phi_n(x_i)$ for $\text{Sin}(n\pi x_i/l)$. The system of equations formed can be written in a matrix system of second order ordinary differential equation as

$$[M] \{\ddot{p}\} + [C] \{\dot{p}\} + [K] \{p\} = \{q\} \quad (14)$$

where $[M]$, $[C]$ and $[K]$ are the system mass, damping and stiffness matrix respectively. The load vector is given by $\{q\}$ and the unknown degrees of freedom are listed in $\{p\}$ as a vector. $[M]$, $[K]$, $[C]$ and $\{q\}$ are all time dependent. This system of second order ordinary differential equation can be solved by numerical techniques. Kwon et al [9] and Jo et al [10] have suggested the use of the average acceleration technique using a method of direct integration since it is unconditionally stable. Here the system of equations is converted in a state space form and solved for the unknown displacements using 4/5th order Runge Kutta method. The displacements are related to moment and shear force according to the relations

$$M(x,t) = -\sum_{i=1}^n EI(d^2\Phi_n(x)/dx^2)q_n(t) \quad (15)$$

$$V(x,t) = -\sum_{i=1}^n EI(d^3\Phi_n(x)/dx^3)q_n(t) \quad (16)$$

respectively. Once these responses are found, reliability analysis can be done taking the variability of different parameters into account by statistical distributions.

3. Reliability Analysis

The formal reliability of a structure may be taken to be a probability of safety or proper performance of the structure over a given period of time [18]. The present discussion about this topic will be constrained to that which is important for the present problem. The bridge considered in the problem will be assumed to have failed under the action of bending moment, shear or due to deflection separately. Here the term failure does not necessarily mean the collapse of a structure as a whole but rather a condition whereby we will declare the structure to have failed according to some predefined threshold value of response. Information about both load and resistance are assumed incomplete and hence they are to be modelled as probability distributions. One can refer to the new equation (also known as failure function) formed by subtracting load from resistance as $G(x)$. The variable x becomes a vector for multidimensional problems. For this formulation the probability of $G(x)$ being less than zero expresses the failure probability. It is sufficient to know the mean and standard deviation of the distributions in the safety margin format of first order second moment (FOSM) reliability analysis. The reliability index is taken to be the relative measure of safety. The reliability index β is given as

$$\beta = \mu_z / \sigma_z \quad (18)$$

μ_z being mean and σ_z , the standard deviation of the joint distribution derived from the interaction between load, R and resistance, S , such that $z = S - R$. The probability of failure (p_f), assuming normal distribution is given as the value of standardized normal, i.e. $\Phi(-\beta)$. The

probability of failure represents a degree of belief rather than having frequentist connotations. An increase in reliability index would indicate a better performance of the structure. In the present discussion the failure functions are chosen to be

$$f_y z_x - (w l^2 / 8 + M_{max}) = 0 \quad (18)$$

$$0.6 f_y A - V_{max} = 0 \quad (19)$$

$$1/100 - (5 \omega l^4 / 384 EI + y_{max}) = 0 \quad (20)$$

with respect to moment (M), shear (V) and deflection (y) respectively. The subscript represents the corresponding maximum effects.

It is very important to note that limiting values for systems with dynamic effects are often different from the static case. In the present discussion the failure criteria is not changed since the performance of TMD would be best visualised under unchanged failure criteria when both static and dynamic effects are combined.

4. Example, Results and Discussion

Numerical examples have been taken up to show the efficiency of TMD from a reliability perspective. Total mass ratio of TMD is taken as 0.04. Data for Figure 2 is given below:

$m = 300000 \text{ N/m}$ (mean), 30000 N/m (standard deviation), 0.1 (coefficient of variation)
 $m_w = 29700 \text{ N}$ (mean), 8910 N (standard deviation), 0.3 (coefficient of variation)
 $m_b = 200000 \text{ N}$ (mean), 60000 N (standard deviation), 0.3 (coefficient of variation)
 $f_y = 180000000 \text{ N/m}^2$ (mean), 45000000 N/m^2 (standard deviation), 0.25 (coefficient of variation)
 $z_x = 6 \text{ m}^3$ $A = 8.57 \text{ m}^2$ (c/s area) $I = 8 \text{ m}^4$ $E = 3 \times 10^{10} \text{ N/m}^2$
 $k_w = 2.35 \times 10^6 \text{ N/m}$ $c_w = 4 \times 10^4 \text{ N-s/m}$ $k_b = 3 \times 10^6 \text{ N/m}$ $c_b = 8 \times 10^4 \text{ N-s/m}$
 $\zeta_n = 0.003$ (structural damping ratio taken same for all modes)

The mean value of f_y in Figure 3 is 200 GPa. The cases considered for the two graphs are: Without TMD, 1 TMD at the middle, 3 TMDs at maximum response point of third mode and 2 TMDs at the middle respectively. Two TMDs at the maximum response point of second mode is found not to be a good choice.

Figure 2 shows a gradual increase in reliability with increase in velocity while Figure 3 manifests a definite minimum value at velocity 100 km/hr.

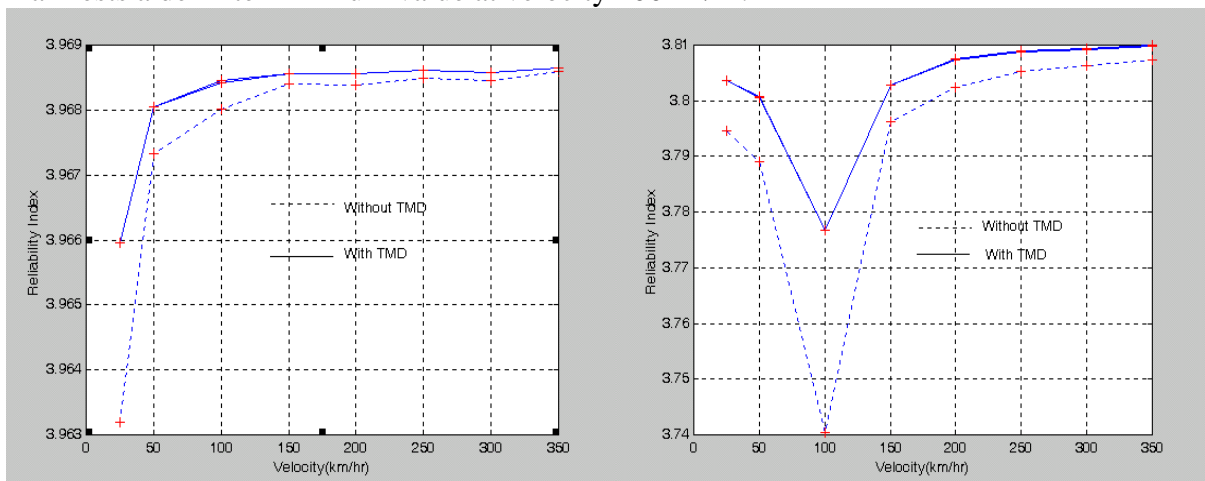

Figure 2.

Figure 3.

It is apparent from both graphs that installation of TMDs demonstrates a relative increase in the reliability index of the structure. It is also important to note that so long as the vibration of the point of maximum response of first assumed mode is suppressed, the relative

improvement in reliability due to introduction of additional TMDs is quite negligible. It should however be remembered that multiple TMDs mitigate free vibration response quickly, catering for a wider range of exciting frequency and are more robust than single TMD. The relative improvement of reliability values, rather than their absolute values are more important here.

Although the graphs are shown for reliability against moment, it can be showed that the shape of these graphs remain unchanged for reliability against shear and deflection. The moment and shear are both related to space derivatives of deflection and have been given in equations (15) and (16). Since the response with respect to time remains unaffected due to the space derivatives taken, the final form for each of the response becomes

$$\mathfrak{G}(x,t) = S + A_i \cdot \Phi_n(x) q_n(t)_{\max} \quad (21)$$

where S is the static part of the response and A_i is a constant multiplicative term for i^{th} component of response (displacement, shear, moment etc) forming from the space derivative. Thus, the term $q_n(t)_{\max}$ remaining unchanged, tends to govern the shape of the graphs for different response.

With time, any structure tends to deteriorate and once the reliability index falls below the target reliability we consider it to be unfit for providing further service. Installation of TMD improves the reliability of the structure and we can extend the lifetime of reaching the target reliability without resorting to repair.

Figure4 shows a parabolic degradation of flexural stiffness of the beam with time. We assume that the deterioration is 5% of initial value in the first 10 years and 10% in the next 10 years.

The equation of deterioration, considering initial value to be 1.0 is given as

$$D(t) = 1 - 0.0025t - 0.00025t^2 \quad (22)$$

where t is time in years from an arbitrary origin. During this period reliability index against deflection is plotted in Figure5 for 80m length of the bridge and vehicle velocity, 100 km/hr. Three cases, viz. without TMD, with a single TMD and with 3 TMDs are considered. Arrangements of TMDs are taken as before. It can be seen that the TMDs perform better both in terms of the relative value of the reliability index and its rate of decrease with time. Use of additional TMDs however improves the reliability index very little.

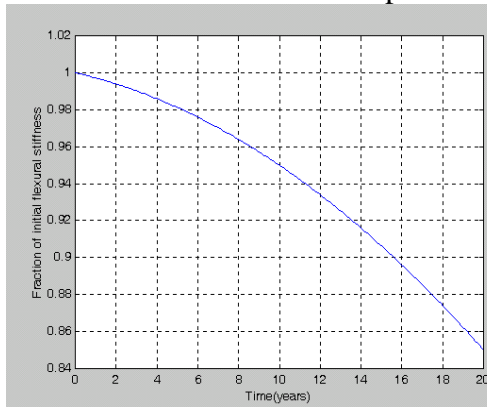

Figure 4.

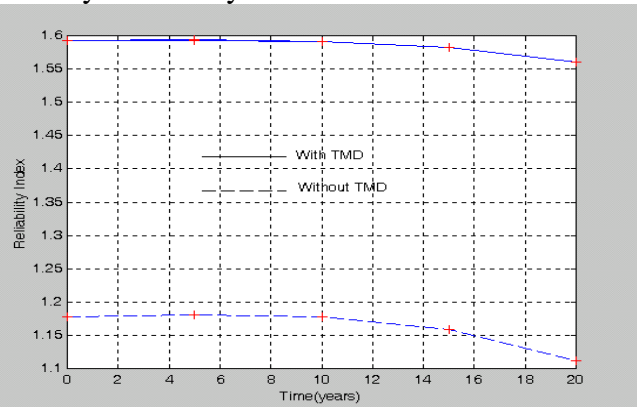
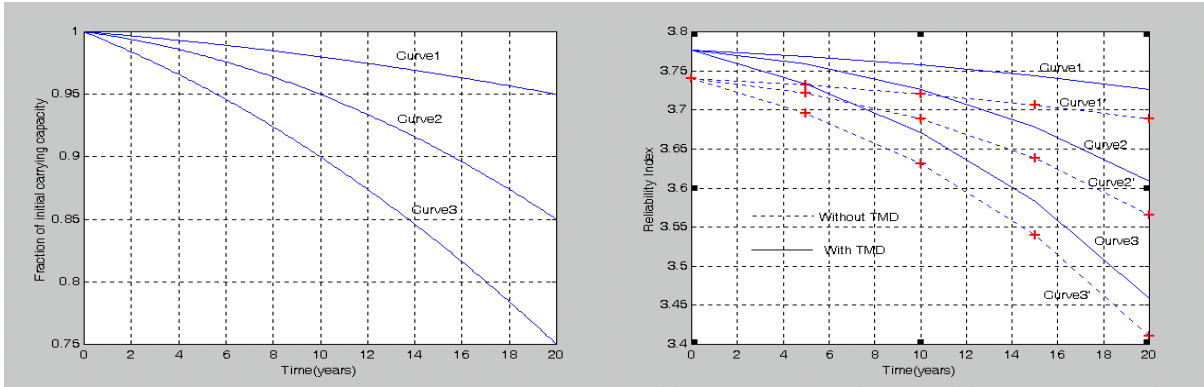

Figure5.

The moment carrying capacity often decreases with time as well. Figure6 shows three such curves with parabolic profile. Although the carrying capacity has a high correlation with flexural stiffness, an equivalent deterioration curve keeping flexural rigidity unchanged, is considered for the present discussion. This shows the effect of TMD installation for the case of decreasing carrying capacity alone. Three TMDs have been used keeping other parameters similar as before. The efficiency of the TMDs is evident in Figure7. The curves involving TMDs reach any particular value of reliability index later than curves without TMD, thereby demonstrating an increase in service life.



Another important factor that changes with time is the coefficient of variation of the random variables. In the present case we assume the change of coefficient of variation of f_y over time as a linear process keeping the mean value constant. Figure 8 shows three such curves. The mean value of f_y is taken as 225GPa. Comparison is done for the system involving no TMD with that involving three TMDs in their previous arrangement. By choosing this significant variation it is seen from Figure 9 that although the TMDs perform better than those without them, the improvement is not significant.

Thus, from the graphs shown, it may be said that for short lifetime extension incorporation of TMDs is fruitful.

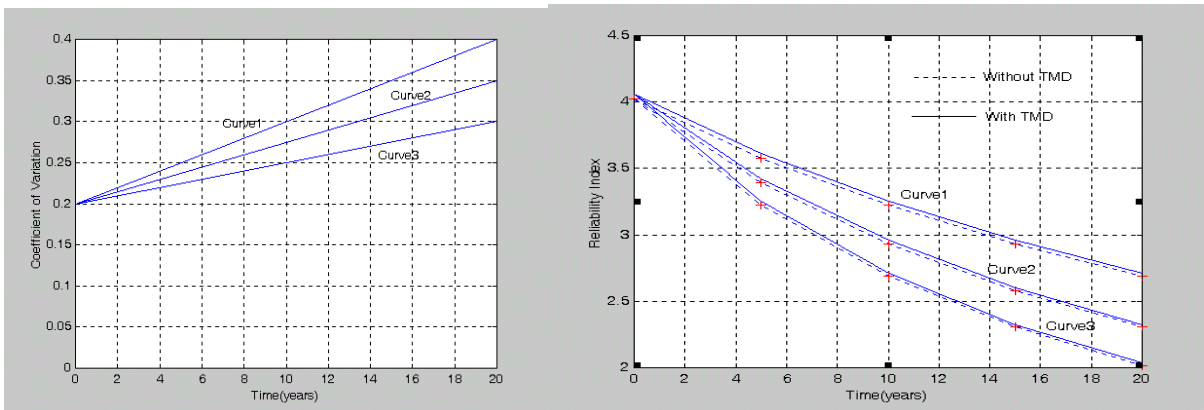

Figure 8.

Figure 9.

4. Conclusion

- The performance of single and multiple TMD with respect to vehicle-induced vibration of bridges have been considered from reliability aspect considering both load and resistance having statistical distributions.
- Installation of TMD demonstrates a relative decrease in the probability of failure for a bridge. It is more pronounced where the dynamic effect is more comparable to the static effects.
- For a deteriorating bridge, installation of TMDs tends to increase its service life to a certain extent.
- So long as the vibration in first mode is suppressed, installation of additional TMD does not affect the reliability index to a great extent.

References

1. Fryba L., *Vibrations of Solids and Structures under Moving Loads*, Thomas Telford, London, 1999.
2. Hayashikawa T, Watanabe N, *Dynamic Behaviour of Continuous Beams with Moving Loads*, Journal Of Engineering Mechanics Division, ASCE, 1981,107(EMI), 229-246

3. Cai Y, Chen S S, Rote D.M, Coffey H.T, *Vehicle/guideway Interaction for High Speed Vehicles on a Flexible Guideway*, Journal of Sound and Vibration, 1994,175(5), 625-646
4. Klasztorny M, Langer J, *Dynamic Response of Single Span Bridges to a Series of Moving Loads*, Earthquake Engineering and Structural Dynamics, 1990,19(8), 1107-1124
5. Genin J, Ginsberg JH, Ting EC, *A complete formulation of inertial effects in the guideway vehicle interaction problem*, Journal of Sound and Vibration, 1975, 38, 15-26
6. Hartog D, *Mechanical Vibration*, Dover Publications, New York, 1985
7. Inman DJ, *Engineering Vibration*, Prentice Hall, New Jersey, 2001
8. Igusa T, K. Xu, *Dynamic Characteristics of Multiple Tuned Mass Substructures with Closely Spaced Frequencies*, Earthquake Engineering and Structural Dynamics, 1992, Vol. 21, 1050-1070.
9. Park J, Reed D.A, *Analysis of Uniformly and Linearly Distributed Mass Dampers Under Harmonic Excitation*, 8th ASCE Specialty Conference on Probabilistic Mechanics and Structural Reliability, PMC2000-031
10. Abe' M., Fujino Y, *Dynamic Characterization of Multiple Tuned Mass Dampers and Some Design Formulas*, Earthquake Engineering and Structural Dynamics, 1994, Vol. 23, 813-835.
11. Kareem A., Kline S *Performance of Multiple Mass Dampers under Random Loading*, Journal of Structural Engineering., 1995, Vol. 121, 348-361.
12. Yamaguchi H, Harnpornchai N, *Fundamental Characteristics of Multiple Tuned Mass Dampers for Suppressing Harmonically Forced Oscillations*, Earthquake Engineering and Structural Dynamics., 1993, Vol. 22, 51-62.
13. Wang J.F, Lin C.C, Chen B.L, *Vibration suppression for high-speed railway bridges using tuned mass dampers*, International Journal of Solids and Structures, 2003, Vol. 40, 465-491
14. Kwon H.C, Kim M.C, Lee I.W, *Vibration Control of Bridges Under Moving Loads*, Computers & Structures, 1998, Vol 66(4), 473-480
15. Jo B.W, Tae G.H, Lee D.W, *Structural Vibration of Tuned Mass Damper Installed Three Span Steel Box Bridge*, International Journal of Pressure VESSELS AND Piping, 2001, 78, 667-675
16. Tsai H.C, *Green's Function of Support Excited Structures with Tuned Mass Dampers Derived by a Perturbation Method*, Earthquake Engineering and Structural Dynamics, 1993,22(11), 975-990
17. Warburton GB, Ayorinde EO, *Optimal dynamic vibration absorbers for general beam systems*, Earthquake Engineering and Structural Dynamics, 1980, 8, 197-217
18. Melchers R.E, *Structural Reliability Analysis and Prediction*, Ellis Horwood Ltd, Chichester, 1987